

Supplementary information

Molecular level characterisation of ion-exchange water treatment coupled to ceramic membrane filtration

Alan J. R. Smith^a, Graeme Moore^b, Andrea J.C. Semiao^c, Dušan Uhrin^{a*}

^a EaStCHEM School of Chemistry, University of Edinburgh, Joseph Black Building, David Brewster Rd, Edinburgh EH9 3FJ, UK.

^b Scottish Water, Castle House, 6 Castle Drive, Dunfermline KY11 8GG, UK

^c School of Engineering, Institute for Infrastructure and Environment, University of Edinburgh, Edinburgh EH8 9YL, UK.

Table of Content

Fig. S1. Schematic setup of the pilot plant.....	2
Fig. S2. A detailed diagram of the SIX treatment stage.....	2
Fig. S3. Schematic setup of the WTW.....	2
Fig. S4. UpSet plot of raw, SIX and ILCA-CMF treated June pilot plant samples.....	3
Fig. S5. Van Krevelen plot of June ILCA-CMF and SIX treated samples.....	3
Fig. S6. Al_{mod} plot for the June pilot plant samples.....	4
Fig. S7. Oxygen series plot for pilot plant June samples.....	4
Fig. S8. Relative integrals of regions of 1H NMR spectra for the pilot plant June samples...	4
Fig. S9. ATR-FT-IR spectra of July pilot plant samples.....	5
Fig. S10. PCA scores plot of the ATR-FT-IR spectra.....	5
Table S1. m/z and associated formulae used to calibrate FT-ICR-MS spectra.....	6

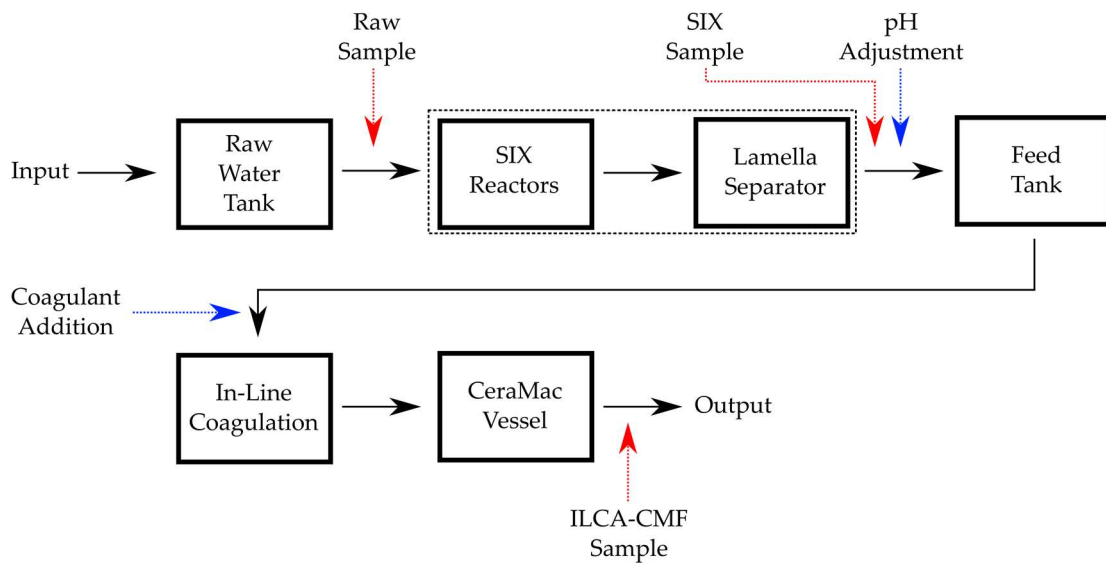

Fig. S1. Schematic setup of the pilot plant. Dashed boxed area is expanded in Fig. S9. Red arrows indicate sampling points.

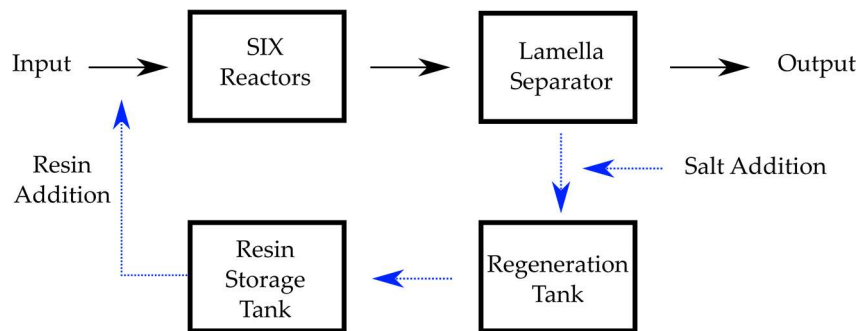

Fig. S2. A detailed diagram of the SIX treatment stage.

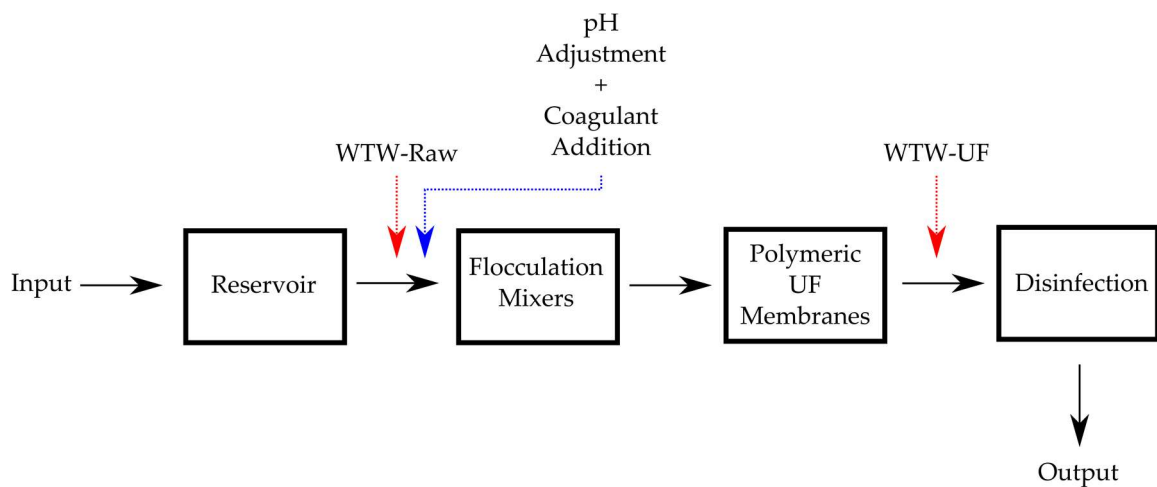

Fig. S3. A schematic diagram of the WTW. Red arrows indicate sampling points.

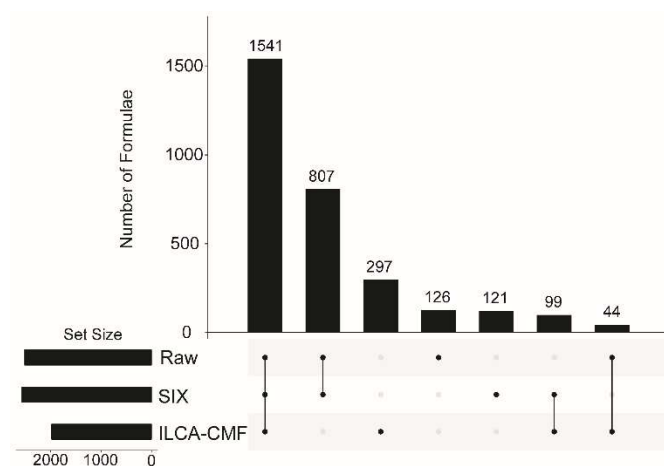

Fig. S4. Upset plot of raw, SIX and ILCA-CMF treated June pilot plant samples. Large similarities between the untreated DOM and SIX treated DOM are visible, as well as significant loss of species after the ILCA-CMF treatment.

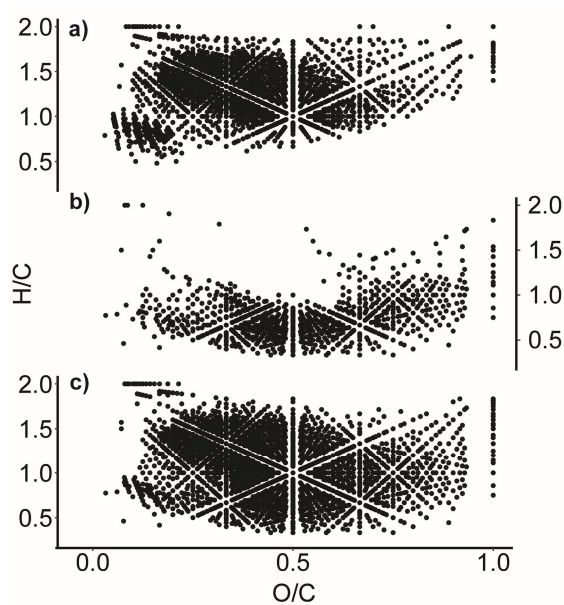

Fig. S5. Van Krevelen plots for June samples. (a) all formulae identified in the ILCA-CMF treated sample; (b) formulae lost after the ILCA-CMF treatment; (c) all formulae identified in the SIX treated sample.

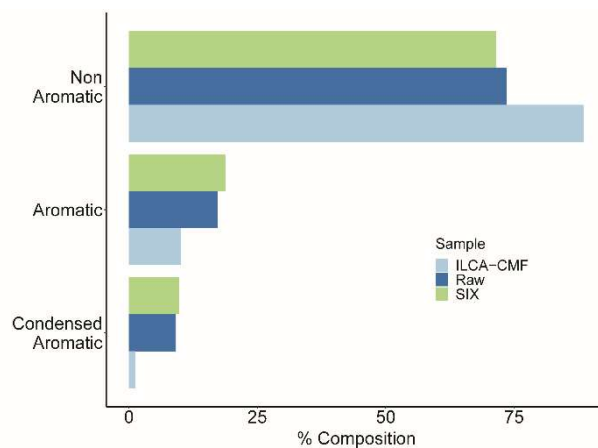

Fig. S6. AI_{mod} plot for the June pilot plant samples. There are far less condensed aromatic species present after the ILCA-CMF treatment.

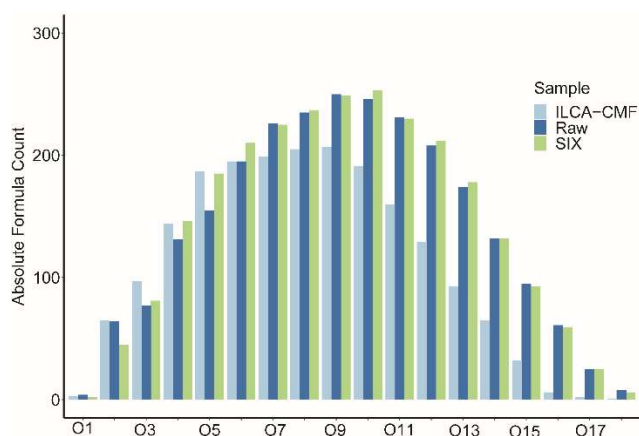

Fig. S7. Oxygen series plot for pilot plant June samples.

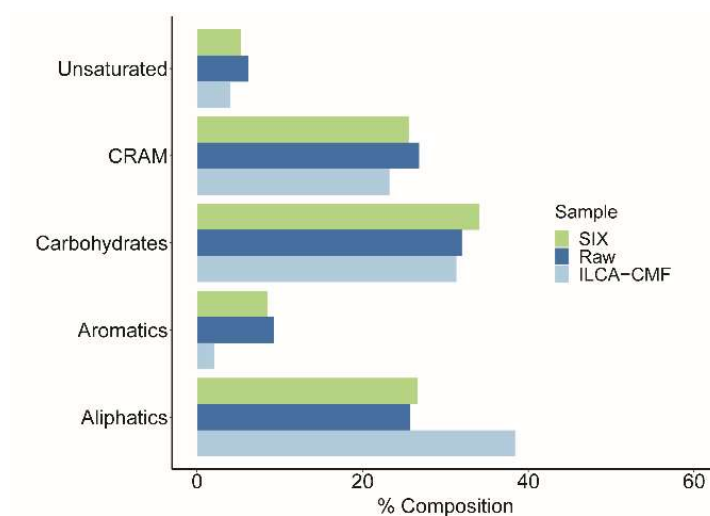

Fig. S8. Relative integrals of regions (shown in Figure 7 of the main article) of 1H NMR spectra of the pilot plant June samples.

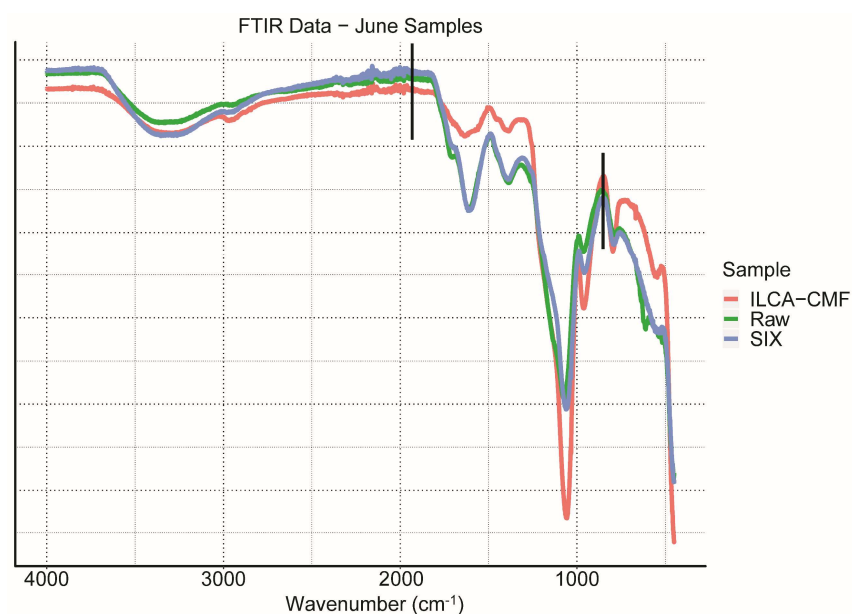

Fig. S9. ATR-FT-IR spectra of July pilot plant samples. The 800-2000 cm⁻¹ region indicated by two black lines was used for the PCA.

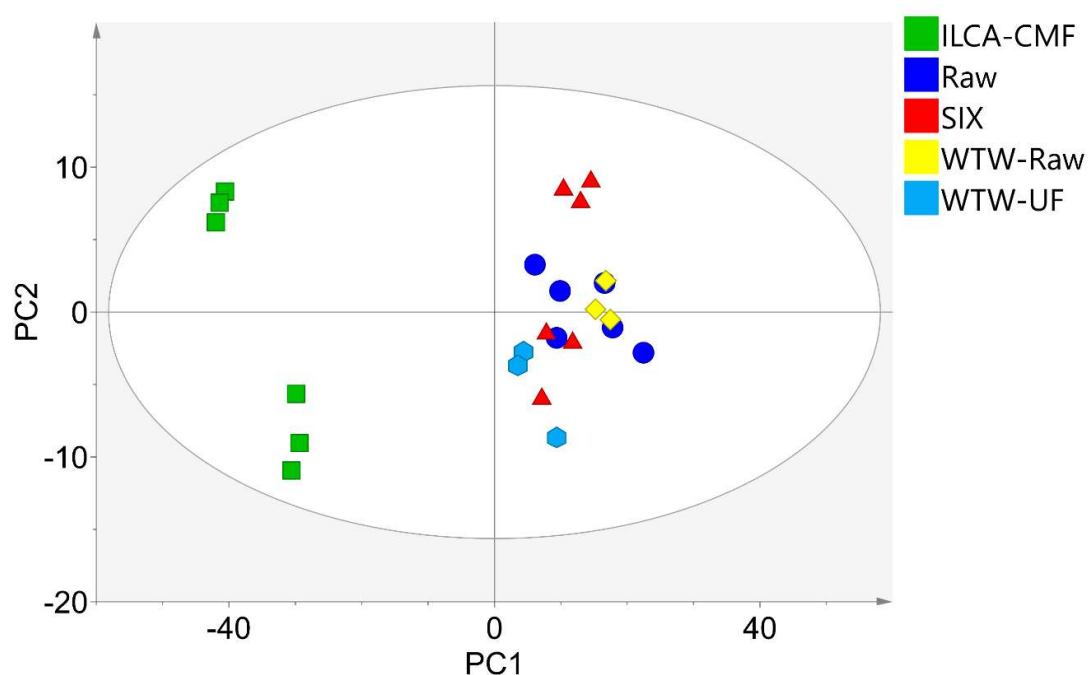

Fig. S10. PCA scores plot of the 800-2000 cm⁻¹ region of the ATR-FT-IR spectra of the July samples (identical plot to Fig. 9a of the main article using shapes to indicate differences between sample types and not the time of collection). **Squares** – ILCA-CMF samples, **Circles** – raw samples, **Triangles** – SIX treated samples, **Diamonds** – WTW-raw samples and **hexagons** – WTW-UF samples.

Table S1. Molecular masses and formulae used to calibrate the FT-ICR-MS spectra of DOM samples.

m/z	Charge	Formula
149.060803	-1	C9H9O2
153.019332	-1	C7H5O4
259.045941	-1	C10H11O8
273.061591	-1	C11H13O8
287.077241	-1	C12H15O8
301.092891	-1	C13H17O8
315.108541	-1	C14H19O8
329.124191	-1	C15H21O8
343.139841	-1	C16H23O8
357.155491	-1	C17H25O8
371.098370	-1	C16H19O10
385.114020	-1	C17H21O10
399.129671	-1	C18H23O10
413.145321	-1	C19H25O10
427.160971	-1	C20H27O10
441.103850	-1	C19H21O12
455.119500	-1	C20H23O12
469.135150	-1	C21H25O12
483.150800	-1	C22H27O12
497.166450	-1	C23H29O12
511.182100	-1	C24H31O12
525.197750	-1	C25H33O12
539.213400	-1	C26H35O12
545.020908	-1	C23H13O16
559.036558	-1	C24H15O16
573.052208	-1	C25H17O16
587.067858	-1	C26H19O16
601.083508	-1	C27H21O16
615.099158	-1	C28H23O16
629.114808	-1	C29H25O16
643.130458	-1	C30H27O16
657.146108	-1	C31H29O16
671.161758	-1	C32H31O16
685.177409	-1	C33H33O16
699.083902	-1	C31H23O19
713.099552	-1	C32H25O19
727.115202	-1	C33H27O19
741.130852	-1	C34H29O19
755.146502	-1	C35H31O19