

(a) Preparation of NiMo/Al₂O₃

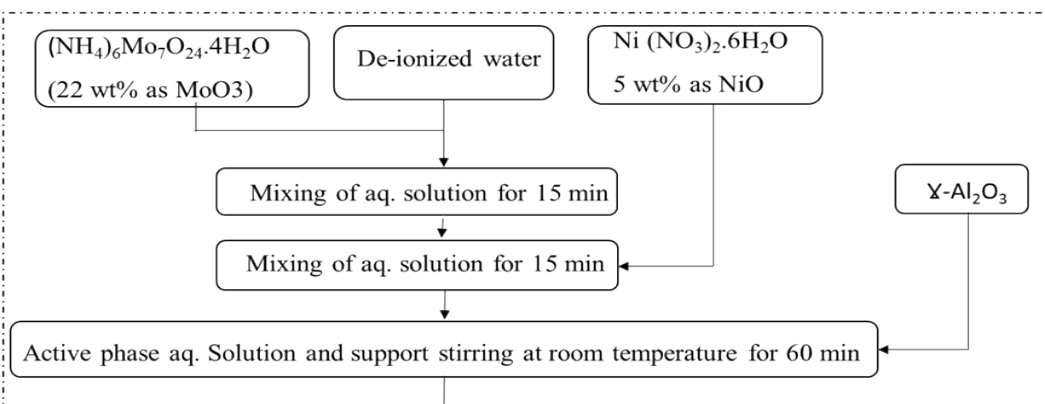

(b) Combustion assisted synthesis NiMo/Al₂O₃

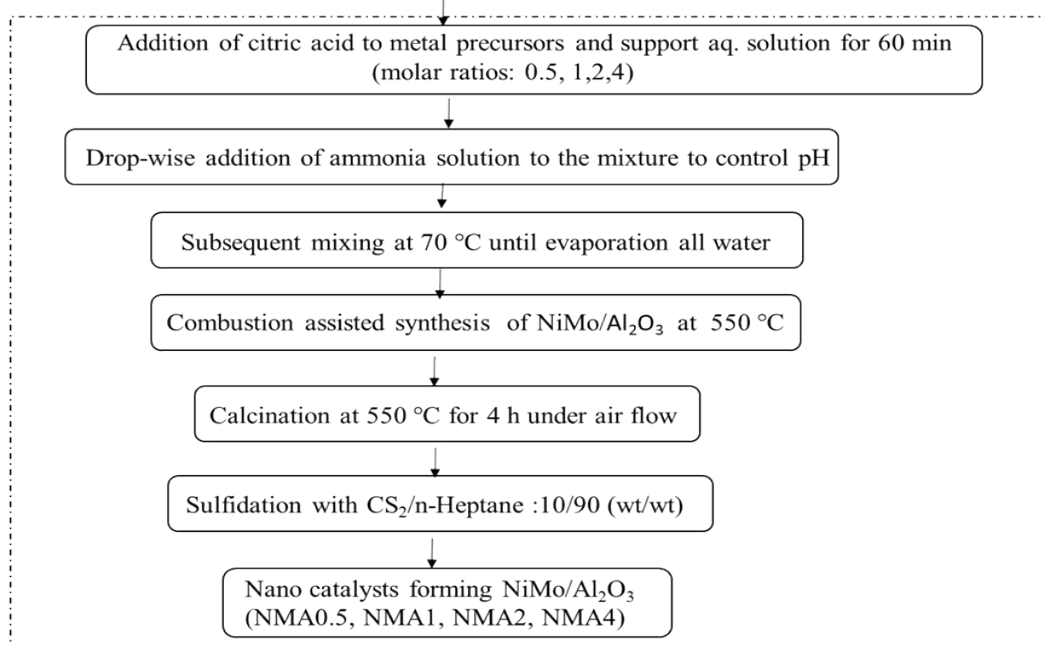

Figure 1.S. Preparation steps of combustion assisted synthesis of NiMo/Al₂O₃

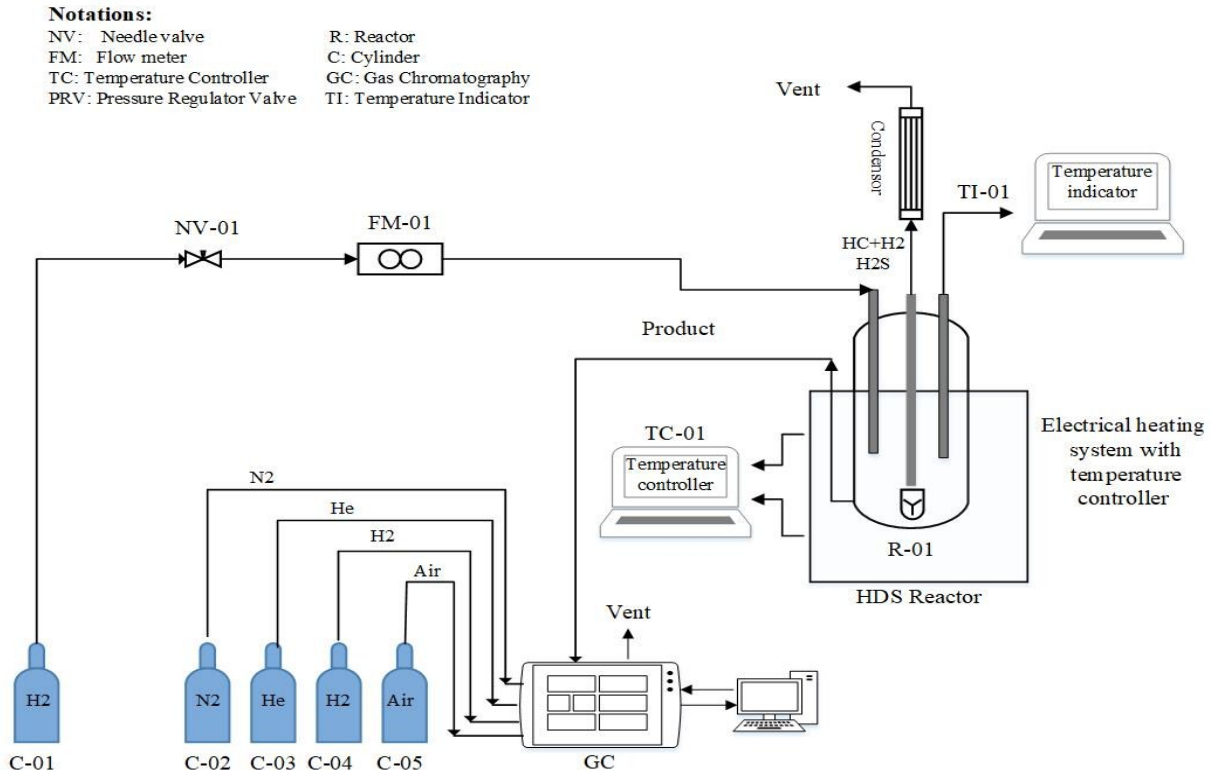

Figure 2.S. Schematic diagram of experimental setup toward hydrodesulfurization process over combusted NMACA-x nanocatalysts