

Supporting Information

Construction of sulfur-containing compounds with anti-cancer stem cell activity using thioacrolein derived from garlic based on nature-inspired scaffolds

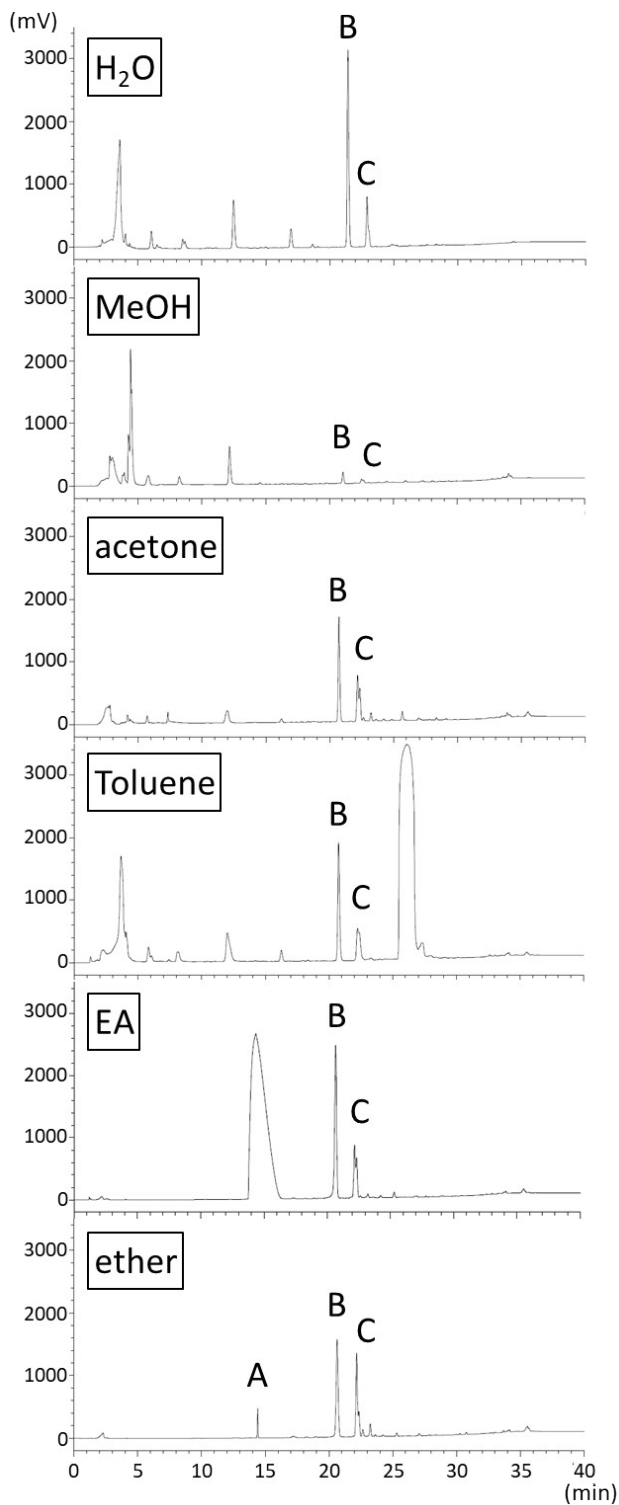
Taichi Yoneda,<sup>a</sup> Naoto Kojima,<sup>a</sup> Takahiro Matsumoto,<sup>a</sup> Daisuke Imahori,<sup>a</sup> Tomoe Ohta,<sup>b</sup> Tatsusada Yoshida,<sup>b</sup> Tetsushi Watanabe,<sup>a</sup> Hisashi Matsuda,<sup>a</sup> and Seikou Nakamura\*<sup>a</sup>

<sup>a</sup>Kyoto Pharmaceutical University, 1 Misasagi-Shichono-cho, Yamashina-ku, Kyoto 607-8412, Japan

<sup>b</sup>Faculty of Pharmaceutical Sciences, Nagasaki International University, 2825-7 Huis Ten Bosch-Cho, Sasebo, Nagasaki 859-3298, Japan

Contents

S2	Examination of allicin ( <b>4</b> ) extraction conditions.
S3	Examination of the reaction between allicin ( <b>4</b> )-containing fraction and dienes.
S4	Overview of synthesis of <b>5</b> .
S5	HPLC analysis chart of <b>anti-5/syn-5</b> .
S6	Presumed regioisomers of thiopyranone.
S7-S50	Computational data of DFT calculations for examination of regioselectivity of Diels-Alder reaction.
S51-S52	The calculated ECD spectra and the measured ECD spectra of <b>5</b> .
S53-S56	The DFT-optimized structures of conformers of <b>5</b> with their equilibrium population.
S57-S104	NMR spectroscopic data of synthesized compounds.



**Figure S1.** Examination of allicin (**4**) extraction conditions.

**[Sample preparation]**

The fresh whole bulb of *Allium sativum* was chopped and blended with solvents [distilled water (H<sub>2</sub>O), methanol (MeOH), acetone, toluene, ethyl acetate (EA), or diethyl ether (ether)] (3 mL / g) for 3 minutes in a mixer. Extracts were analyzed directly by LCMS.

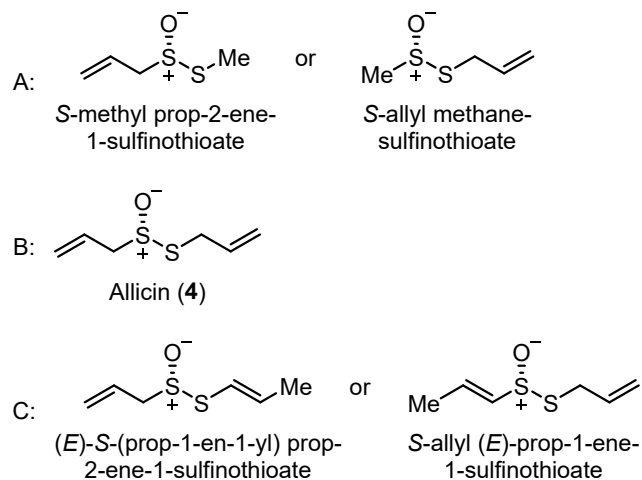
**[Analysis conditions]**

System: Shimadzu LabSolutions  
 Column: YMC-triart PFP, 4.6×250 mm i.d.  
 Mobile phase A: H<sub>2</sub>O, B: MeOH,  
 gradient: mobile phase A–B  
 0.0–30.0 min: linear gradient with 90–10→0–100,  
 30.0–40.0min: linear gradient with 0–100→0–100  
 Detection: UV (210 nm) and ESI MS  
 Flow rate: 0.8 mL/min  
 Column oven: 40 °C  
 Sample injection: 10 mL

A: m/z 137 [M + H]<sup>+</sup>

B: m/z 163 [M + H]<sup>+</sup>

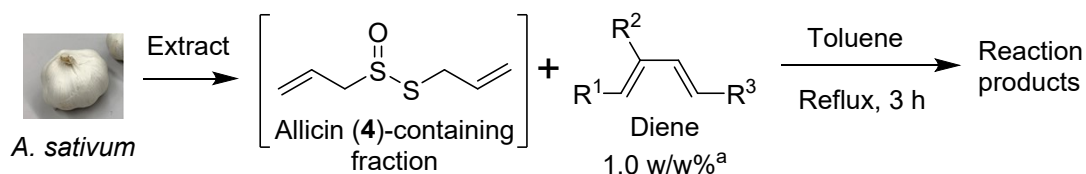
C: m/z 163 [M + H]<sup>+</sup>

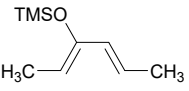
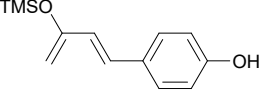
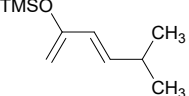
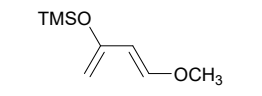
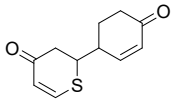
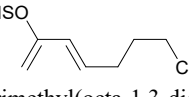
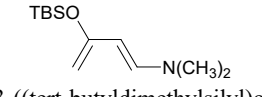
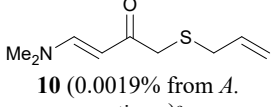
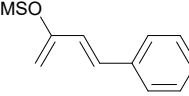


**Figure S2.** Structure of thiosulfinates derived from garlic.

**References**

- [1] E. Block, S. Naganathan, D. Putman and S. H. Zhao, *J. Agric. Food Chem.*, 1992, **40**, 2418–2430.



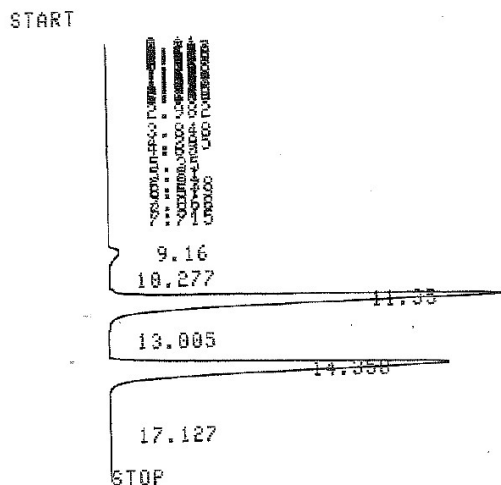
Entry	Diene	Product	Entry	Diene	Product
1	 (( <i>2Z,4E</i> )-hexa-2,4-dien-3-yl)oxytrimethylsilane ( <b>6a</b> )	none <sup>b</sup>	5	 ( <i>E</i> )-4-(3-((trimethylsilyl)oxy)buta-1,3-dien-1-yl)phenol ( <b>6e</b> )	none <sup>b</sup>
2	 ( <i>E</i> )-trimethyl((5-methylhexa-1,3-dien-2-yl)oxy)silane ( <b>6b</b> )	none <sup>b</sup>	6	 ( <i>E</i> )-((4-methoxybuta-1,3-dien-2-yl)oxy)trimethylsilane ( <b>6f</b> )	 <b>5</b> (0.006% from <i>A. sativum</i> ) <sup>c</sup>
3	 ( <i>E</i> )-trimethyl(octa-1,3-dien-2-yl)oxy)silane ( <b>6c</b> )	none <sup>b</sup>	7	 ( <i>E</i> )-3-(( <i>tert</i> -butyldimethylsilyl)oxy)- <i>N,N</i> -dimethylbuta-1,3-dien-1-amine ( <b>6g</b> )	 <b>10</b> (0.0019% from <i>A. sativum</i> ) <sup>c</sup>
4	 ( <i>E</i> )-trimethyl((4-phenylbuta-1,3-dien-2-yl)oxy)silane ( <b>6d</b> )	none <sup>b</sup>			

<sup>a</sup>Calculated from the fresh weight of garlic whole bulb. <sup>b</sup>No reaction product of *A. sativum*-derived component and diene was isolated. <sup>c</sup>Isolation yield from the fresh weight of garlic whole bulb.

**Figure S3.** Examination of the reaction between allicin (**4**)-containing fraction and dienes (**6**)







**Figure S5.** HPLC analysis chart of **anti-5**

[Analysis conditions]

Column: CHIRAL PAC AD-H, 4.6×250 mm i.d.

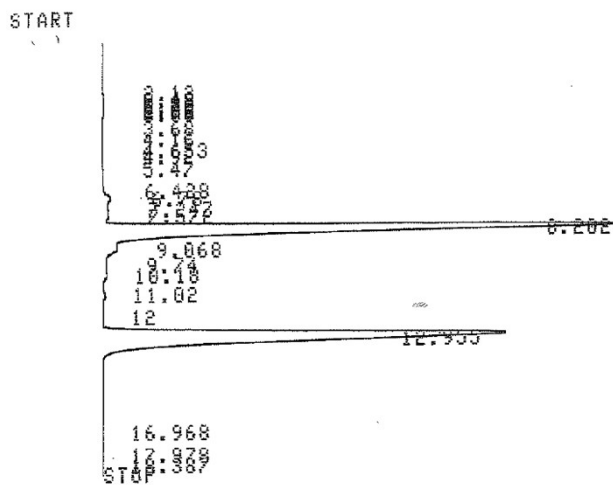
Mobile phase: *n*-Hexane : 2-Propanol = 60 : 40

Detection: UV (315 nm)

Flow rate: 1 mL/min

Sample preparation: **anti-5** 1.6 mg / 0.5 mL [*n*-Hexane : 2-Propanol = 60 : 40]

Sample injection: 10 μL



**Figure S6.** HPLC analysis chart of **syn-5**

[Analysis conditions]

Column: CHIRAL PAC AD-H, 4.6×250 mm i.d.

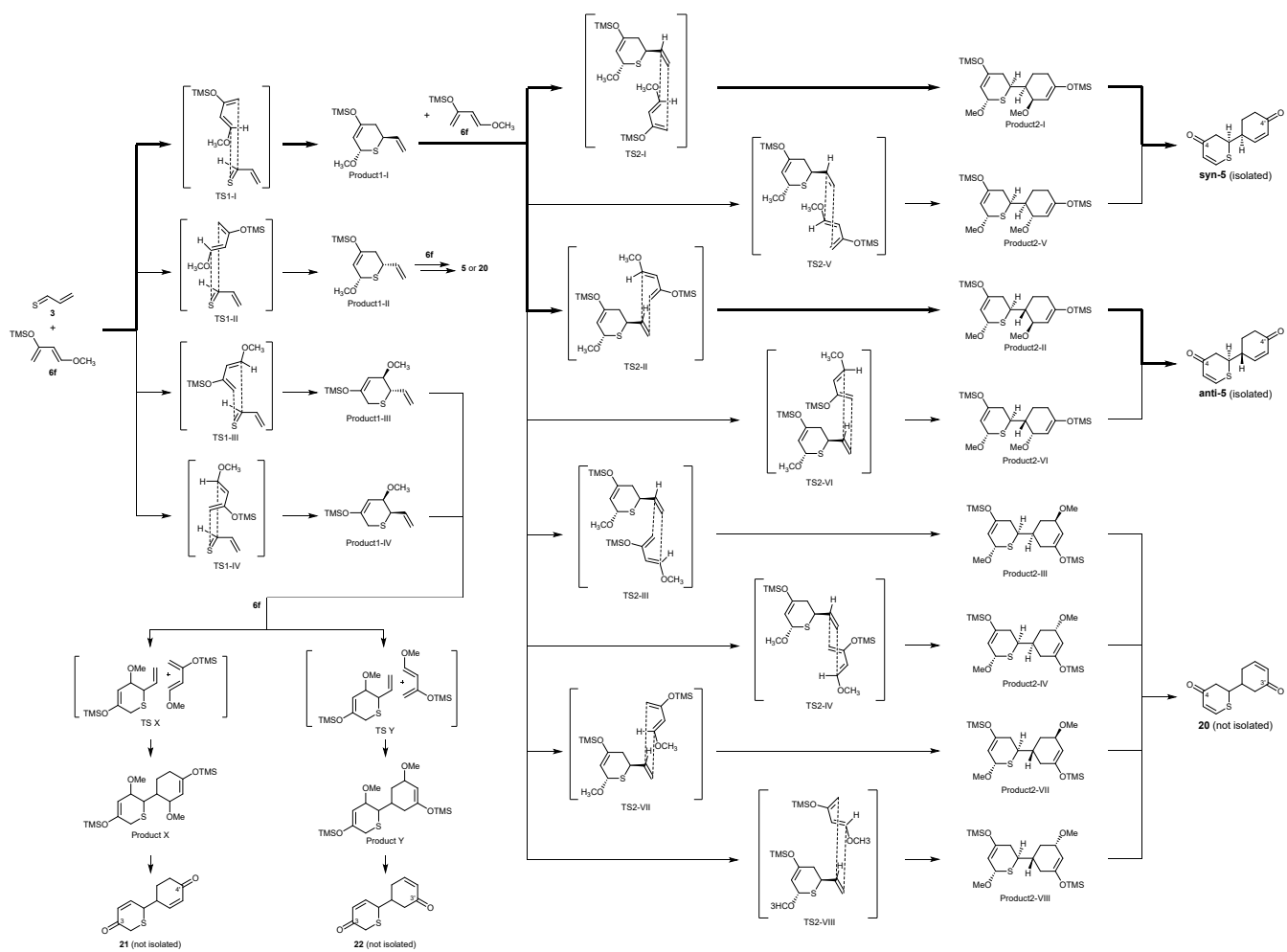
Mobile phase: *n*-Hexane : 2-Propanol = 50 : 50

Detection: UV (315 nm)

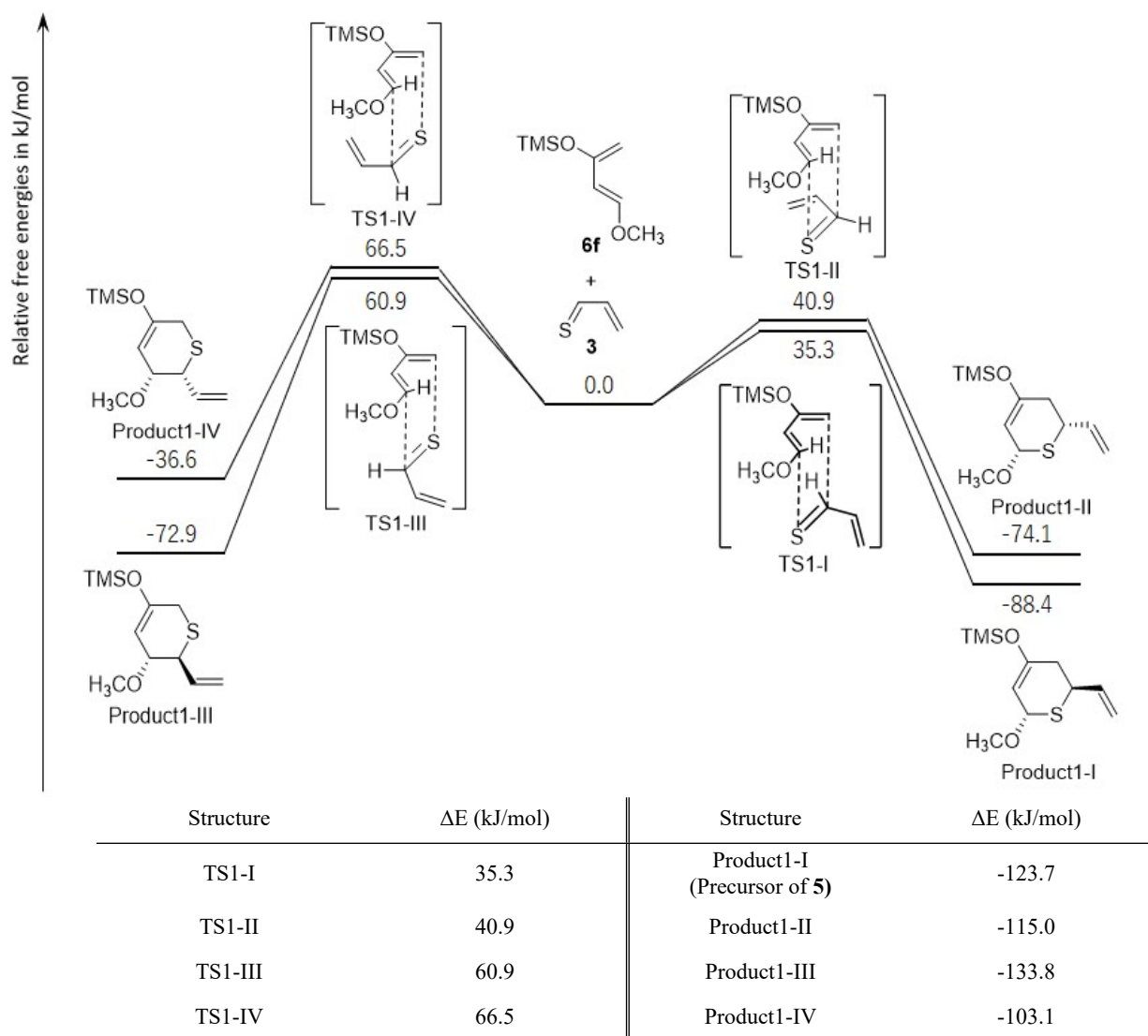
Flow rate: 1 mL/min

Sample preparation: **syn-5** 1.9 mg / 0.5 mL [*n*-Hexane : 2-Propanol = 50 : 50]

Sample injection: 10 μL

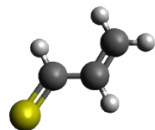


**Figure S7.** Presumed regioisomers of thiopyranone



**Figure S8.** DFT computed Gibbs free energies and transition state structures for thio-Diels–Alder reactions of thioacrolein (**3**) and Danishefsky’s diene (**6f**).

### Thioacrolein (3)



HF = -514.8848786 hartrees

Imaginary Frequencies: none found

Zero-point correction = 0.059696 (Hartree/Particle)

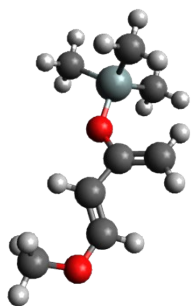
Temperature: 298.150 Kelvin. Pressure: 1.00000 Atm.

Sum of electronic and zero-point Energies = -514.825183 hartrees

Coordinates:

Center Number	Atomic Number	Atomic Type	Coordinates (Angstroms)		
			X	Y	Z
1	16	0	-1.656594	-0.072050	0.000001
2	6	0	-0.091167	0.434537	-0.000004
3	1	0	0.122520	1.506639	0.000002
4	6	0	1.070620	-0.423759	-0.000002
5	1	0	0.901493	-1.497391	-0.000000
6	6	0	2.319250	0.081266	0.000000
7	1	0	3.192932	-0.562084	0.000008
8	1	0	2.496337	1.153378	0.000005

### Danishefsky's diene (6f)



HF = -754.4783627 hartrees

Imaginary Frequencies: none found

Zero-point correction = 0.224657 (Hartree/Particle)

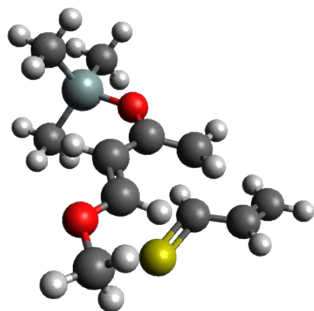
Temperature: 298.150 Kelvin. Pressure: 1.00000 Atm.

Sum of electronic and zero-point Energies = -754.253706 hartrees

Coordinates:

Center Number	Atomic Number	Atomic Type	Coordinates (Angstroms)		
			X	Y	Z
1	6	0	-0.240878	-1.908538	0.279825
2	1	0	0.746187	-2.343962	0.187264
3	1	0	-1.057385	-2.574843	0.527356
4	6	0	-2.913480	-0.596280	-0.313309
5	6	0	-0.473981	-0.595474	0.094874
6	6	0	-1.804627	0.031487	0.116658
7	1	0	-1.838060	1.058242	0.465635
8	8	0	0.503773	0.339639	-0.135439
9	14	0	2.198266	0.245035	-0.027385
10	6	0	2.709812	-0.347698	1.685069
11	1	0	2.335425	0.329928	2.459705
12	1	0	2.334760	-1.350814	1.906812
13	1	0	3.802678	-0.372326	1.763399
14	6	0	2.744201	2.019590	-0.310154
15	1	0	2.418310	2.383226	-1.290152
16	1	0	2.331163	2.687674	0.452587
17	1	0	3.836177	2.099319	-0.269872
18	6	0	2.883222	-0.870965	-1.381742
19	1	0	3.978752	-0.835162	-1.377515
20	1	0	2.585031	-1.916619	-1.261258
21	1	0	2.544067	-0.537266	-2.368251
22	8	0	-4.184550	-0.133278	-0.313008
23	1	0	-2.877130	-1.597696	-0.732128
24	6	0	-4.408606	1.167509	0.230465
25	1	0	-5.483172	1.341139	0.172994
26	1	0	-4.079545	1.217599	1.274688
27	1	0	-3.880746	1.932394	-0.350419

TS1-I

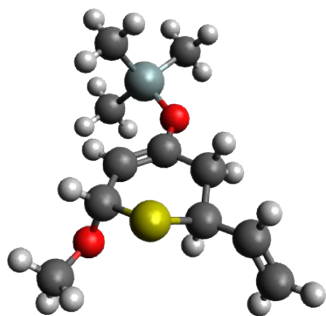


HF = -1269.351052 hartrees  
 Imaginary Frequencies: 1 (-289.7197 1/cm)  
 Zero-point correction = 0.285591 (Hartree/Particle)  
 Temperature: 298.150 Kelvin. Pressure: 1.00000 Atm.  
 Sum of electronic and zero-point Energies = -1269.065461 hartrees

Coordinates:

Center Number	Atomic Number	Atomic Type	Coordinates (Angstroms)		
			X	Y	Z
1	6	0	1.242446	1.872656	-0.548630
2	6	0	0.011130	1.289170	-0.515198
3	1	0	-0.804430	1.877146	-0.109750
4	6	0	-0.229230	-0.069417	-0.892654
5	6	0	0.743867	-0.925548	-1.383746
6	1	0	0.433564	-1.909157	-1.711808
7	1	0	1.631459	-0.520723	-1.850097
8	16	0	2.451729	-0.289484	1.340593
9	6	0	1.870729	-1.613198	0.445591
10	8	0	-1.444830	-0.613906	-0.666172
11	14	0	-2.865446	-0.133205	0.161573
12	6	0	-3.672707	1.303804	-0.746134
13	1	0	-3.082120	2.223920	-0.704883
14	1	0	-3.837917	1.055827	-1.799829
15	1	0	-4.649779	1.518768	-0.298375
16	6	0	-3.937020	-1.668417	0.057794
17	1	0	-3.457409	-2.520434	0.550012
18	1	0	-4.901720	-1.496791	0.547748
19	1	0	-4.133994	-1.944453	-0.983061
20	6	0	-2.459197	0.294240	1.946543
21	1	0	-1.958215	-0.542421	2.444170
22	1	0	-1.814305	1.172992	2.036738
23	1	0	-3.385180	0.502720	2.494729
24	8	0	1.403047	3.129828	-0.124970
25	1	0	2.119096	1.383728	-0.960760
26	6	0	2.746780	3.639010	-0.164097
27	1	0	3.129502	3.641704	-1.189327
28	1	0	2.696341	4.659870	0.212220
29	1	0	3.398676	3.037086	0.476140
30	6	0	2.797383	-2.487192	-0.288614
31	1	0	3.722777	-2.022725	-0.624142
32	6	0	2.580659	-3.793003	-0.501004
33	1	0	1.669931	-4.281798	-0.163800
34	1	0	3.312955	-4.414510	-1.006450
35	1	0	0.964579	-2.104136	0.799058

## Product1-I



HF = -1269.4023132 hartrees

Imaginary Frequencies: none found

Zero-point correction = 0.289751 (Hartree/Particle)

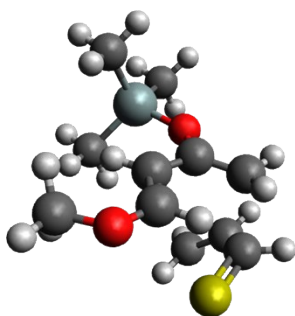
Temperature: 298.150 Kelvin. Pressure: 1.00000 Atm.

Sum of electronic and zero-point Energies = -1269.112562 hartrees

Coordinates:

Center Number	Atomic Number	Atomic Type	Coordinates (Angstroms)		
			X	Y	Z
1	6	0	-1.297433	-1.493902	-0.409422
2	6	0	0.061463	-0.916863	-0.139139
3	1	0	0.843573	-1.662850	-0.035592
4	6	0	0.361321	0.383786	0.007794
5	6	0	-0.627797	1.521133	-0.038149
6	1	0	-0.349462	2.230641	0.750893
7	1	0	-0.510157	2.056253	-0.990428
8	16	0	-2.523844	-0.244250	-1.031000
9	6	0	-2.091060	1.113938	0.157870
10	8	0	1.621495	0.855845	0.222196
11	14	0	3.160643	0.140813	0.045284
12	6	0	3.335247	-0.571850	-1.687446
13	1	0	2.612193	-1.368522	-1.884570
14	1	0	3.194820	0.205882	-2.445412
15	1	0	4.339244	-0.990348	-1.820775
16	6	0	4.328181	1.587262	0.304245
17	1	0	4.194069	2.031854	1.295754
18	1	0	5.370751	1.260712	0.222213
19	1	0	4.161725	2.369900	-0.442906
20	6	0	3.434146	-1.168489	1.370575
21	1	0	3.249436	-0.757603	2.368754
22	1	0	2.791031	-2.044453	1.243980
23	1	0	4.474031	-1.513930	1.340859
24	8	0	-1.728935	-2.157521	0.766003
25	1	0	-1.237132	-2.216103	-1.237103
26	6	0	-2.756395	-3.117532	0.550853
27	1	0	-2.437394	-3.891083	-0.162551
28	1	0	-2.960692	-3.584060	1.516563
29	1	0	-3.674618	-2.648559	0.175715
30	6	0	-3.032732	2.264367	-0.052704
31	1	0	-2.947052	2.778484	-1.010148
32	6	0	-3.927553	2.678880	0.844752
33	1	0	-4.038818	2.188783	1.808894
34	1	0	-4.579918	3.523950	0.646761
35	1	0	-2.227915	0.696684	1.160163

TS1-II



HF = -1269.3500071 hartrees

Imaginary Frequencies: 1 (-298.2156 1/cm)

Zero-point correction = 0.286709 (Hartree/Particle)

Temperature: 298.150 Kelvin. Pressure: 1.00000 Atm.

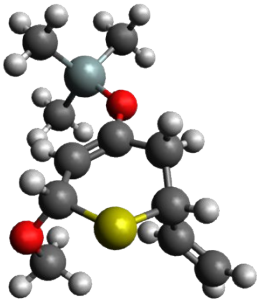
Sum of electronic and zero-point Energies = -1269.063298 hartrees

Coordinates:

Center Number	Atomic Number	Atomic Type	Coordinates (Angstroms)		
			X	Y	Z
1	6	0	1.697333	1.722984	-0.620217
2	6	0	0.447248	1.200021	-0.452806
3	1	0	-0.238802	1.680524	0.232093
4	6	0	0.007272	-0.005494	-1.092313
5	6	0	0.811106	-0.812526	-1.886567
6	1	0	0.332311	-1.637077	-2.401812
7	1	0	1.690372	-0.396738	-2.357821
8	16	0	3.169183	-0.905758	0.327000
9	6	0	2.066260	-1.945952	-0.446123
10	1	0	2.415404	-2.431247	-1.356467
11	6	0	1.007647	-2.707167	0.246326
12	1	0	0.424098	-3.366455	-0.395051
13	6	0	0.736228	-2.666811	1.557392
14	1	0	-0.050138	-3.280278	1.985626
15	1	0	1.306155	-2.032405	2.229178
16	8	0	-1.227748	-0.473339	-0.830197
17	14	0	-2.580649	0.044838	0.084638
18	6	0	-3.209933	1.671879	-0.618748
19	1	0	-2.483010	2.483744	-0.519312
20	1	0	-3.456410	1.568675	-1.680551
21	1	0	-4.121732	1.976566	-0.092621
22	6	0	-3.814024	-1.338338	-0.195451
23	1	0	-3.431639	-2.291919	0.182109
24	1	0	-4.755007	-1.124495	0.323107
25	1	0	-4.037133	-1.459745	-1.260178
26	6	0	-2.136109	0.188247	1.906676
27	1	0	-1.472247	1.029794	2.125412
28	1	0	-3.051257	0.328659	2.493540
29	1	0	-1.647230	-0.725369	2.259224
30	8	0	2.194466	2.809268	-0.026277
31	1	0	2.409546	1.318902	-1.328153
32	6	0	1.413051	3.463431	0.983024
33	1	0	1.178631	2.769979	1.796448
34	1	0	2.031757	4.278499	1.355510
35	1	0	0.488266	3.865709	0.557416



## Product1-II



HF = - 1269.3973179 hartrees

Imaginary Frequencies: none found

Zero-point correction = 0.290231 (Hartree/Particle)

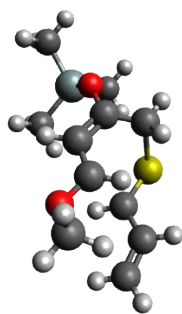
Temperature: 298.150 Kelvin. Pressure: 1.00000 Atm.

Sum of electronic and zero-point Energies = -1269.107087 hartrees

Coordinates:

Center Number	Atomic Number	Atomic Type	Coordinates (Angstroms)		
			X	Y	Z
1	6	0	1.421980	1.519976	-0.682599
2	6	0	0.108795	0.885875	-0.320669
3	1	0	-0.617499	1.608905	0.040531
4	6	0	-0.252879	-0.399327	-0.474430
5	6	0	0.657075	-1.501449	-0.959082
6	1	0	0.285781	-2.444490	-0.543775
7	1	0	0.580046	-1.583102	-2.050346
8	16	0	2.761843	0.314871	-1.171406
9	6	0	2.130061	-1.326771	-0.562964
10	1	0	2.732447	-2.036188	-1.138231
11	6	0	2.377925	-1.554901	0.901929
12	1	0	1.754269	-0.986558	1.588831
13	6	0	3.282182	-2.410034	1.382527
14	1	0	3.419261	-2.551432	2.450377
15	1	0	3.920699	-2.996819	0.726022
16	8	0	-1.504358	-0.873363	-0.222172
17	14	0	-2.987707	-0.095718	0.110388
18	6	0	-3.396005	1.123692	-1.263501
19	1	0	-2.677943	1.946379	-1.324558
20	1	0	-3.417258	0.621673	-2.236483
21	1	0	-4.387311	1.558249	-1.091609
22	6	0	-4.210563	-1.518770	0.132083
23	1	0	-3.948960	-2.254573	0.899370
24	1	0	-5.221133	-1.154808	0.347836
25	1	0	-4.238287	-2.032518	-0.834227
26	6	0	-2.917403	0.741469	1.795279
27	1	0	-2.202355	1.568760	1.829720
28	1	0	-3.903736	1.144871	2.051737
29	1	0	-2.639610	0.023910	2.574603
30	8	0	1.854805	2.472704	0.273731
31	1	0	1.301662	2.125208	-1.587309
32	6	0	2.076985	1.990241	1.593089
33	1	0	2.878609	1.241942	1.615662
34	1	0	2.377846	2.854564	2.188642
35	1	0	1.169386	1.553406	2.027818

TS1-III

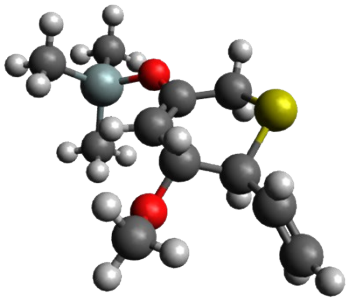


HF = -1269.3412107 hartrees  
 Imaginary Frequencies: 1 (-303.7707 1/cm)  
 Zero-point correction = 0.285518 (Hartree/Particle)  
 Temperature: 298.150 Kelvin. Pressure: 1.00000 Atm.  
 Sum of electronic and zero-point Energies = -1269.055693 hartrees

Coordinates:

Center Number	Atomic Number	Atomic Type	Coordinates (Angstroms)		
			X	Y	Z
1	6	0	1.699291	1.126559	-0.470309
2	6	0	0.316891	1.268416	-0.448742
3	1	0	-0.102420	2.031362	0.199463
4	6	0	-0.546143	0.387537	-1.103506
5	6	0	-0.066590	-0.757954	-1.794502
6	1	0	-0.819625	-1.371550	-2.281022
7	1	0	0.843656	-0.653353	-2.374740
8	8	0	-1.890181	0.544845	-0.967129
9	14	0	-2.955421	0.187654	0.318421
10	6	0	-4.459015	1.250031	-0.046829
11	1	0	-4.209964	2.315810	-0.021754
12	1	0	-4.873687	1.022177	-1.034237
13	1	0	-5.245330	1.070953	0.694833
14	6	0	-3.385992	-1.641244	0.259225
15	1	0	-2.495807	-2.260101	0.409414
16	1	0	-4.108413	-1.890824	1.044915
17	1	0	-3.831593	-1.912200	-0.703717
18	6	0	-2.171155	0.636657	1.967900
19	1	0	-1.235216	0.093580	2.132540
20	1	0	-1.962341	1.708610	2.043672
21	1	0	-2.855276	0.372207	2.782477
22	8	0	2.448476	1.943607	0.290770
23	1	0	2.217189	0.602334	-1.266038
24	6	0	3.748635	2.278710	-0.225020
25	1	0	4.265310	1.387300	-0.586278
26	1	0	3.653778	3.014039	-1.031465
27	1	0	4.306765	2.713320	0.604188
28	6	0	1.894280	-1.144594	0.539946
29	1	0	1.632383	-0.701431	1.498229
30	6	0	3.306183	-1.355649	0.285247
31	1	0	3.554384	-1.857262	-0.650652
32	6	0	4.303403	-0.991908	1.116824
33	1	0	4.102127	-0.508415	2.069254
34	1	0	5.343153	-1.180671	0.870227
35	16	0	0.680733	-2.054376	-0.245483

### Product1-III

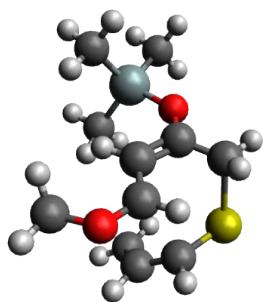


HF = - 1269.3962618 hartrees  
Imaginary Frequencies: none found  
Zero-point correction = 0.289612 (Hartree/Particle)  
Temperature: 298.150 Kelvin. Pressure: 1.00000 Atm.  
Sum of electronic and zero-point Energies = -1269.106650 hartrees

#### Coordinates:

Center Number	Atomic Number	Atomic Type	Coordinates (Angstroms)		
			X	Y	Z
1	6	0	1.539171	0.697075	-0.472993
2	6	0	0.051879	0.440811	-0.476011
3	1	0	-0.542696	1.331944	-0.650246
4	6	0	-0.564084	-0.733025	-0.278394
5	6	0	0.122711	-2.056668	-0.059638
6	1	0	-0.031276	-2.385075	0.974845
7	1	0	-0.339795	-2.806627	-0.708312
8	8	0	-1.919254	-0.901821	-0.242190
9	14	0	-3.176389	0.185595	0.143441
10	6	0	-4.662213	-0.940889	0.359093
11	1	0	-4.868305	-1.503990	-0.557019
12	1	0	-4.500918	-1.659626	1.168939
13	1	0	-5.557226	-0.357151	0.601006
14	6	0	-2.758646	1.089433	1.739479
15	1	0	-1.830365	1.662050	1.656388
16	1	0	-3.562243	1.787980	1.998323
17	1	0	-2.647462	0.385362	2.570765
18	6	0	-3.467859	1.384606	-1.279337
19	1	0	-2.639894	2.085945	-1.420322
20	1	0	-3.616390	0.845265	-2.220854
21	1	0	-4.371811	1.974649	-1.088564
22	8	0	1.733100	1.947306	0.206248
23	1	0	1.904664	0.792077	-1.507997
24	6	0	2.651939	2.834091	-0.417554
25	1	0	3.671191	2.429957	-0.440828
26	1	0	2.345218	3.077633	-1.444862
27	1	0	2.653015	3.752387	0.175112
28	6	0	2.359054	-0.400748	0.236947
29	1	0	2.090876	-0.397503	1.298154
30	6	0	3.843970	-0.238114	0.080061
31	1	0	4.211718	-0.187579	-0.944925
32	6	0	4.704932	-0.170934	1.096550
33	1	0	4.372980	-0.222825	2.130396
34	1	0	5.771883	-0.058963	0.929354
35	16	0	1.907525	-2.058871	-0.463076

TS1-IV

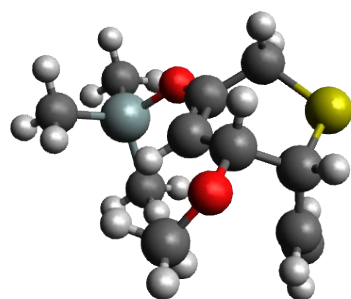


HF = -1269.339 8135 hartrees  
 Imaginary Frequencies: 1 (-263.0759 1/cm)  
 Zero-point correction = 0.286249 (Hartree/Particle)  
 Temperature: 298.150 Kelvin. Pressure: 1.00000 Atm.  
 Sum of electronic and zero-point Energies = -1269.053565 hartrees

Coordinates:

Center Number	Atomic Number	Atomic Type	Coordinates (Angstroms)		
			X	Y	Z
1	6	0	1.712999	1.059785	-1.089971
2	6	0	0.378071	0.810326	-0.806305
3	1	0	-0.169407	1.515847	-0.194837
4	6	0	-0.237837	-0.404731	-1.145959
5	6	0	0.488110	-1.450800	-1.780772
6	1	0	-0.088605	-2.341219	-2.014989
7	1	0	1.176462	-1.165599	-2.568065
8	8	0	-1.491342	-0.713898	-0.746719
9	14	0	-2.678919	0.068939	0.204934
10	6	0	-3.125633	1.727770	-0.565368
11	1	0	-2.317002	2.462708	-0.512160
12	1	0	-3.401910	1.607107	-1.618126
13	1	0	-3.990660	2.151110	-0.041932
14	6	0	-4.129241	-1.115171	0.111542
15	1	0	-3.858435	-2.102278	0.499445
16	1	0	-4.969834	-0.739836	0.705479
17	1	0	-4.475559	-1.238569	-0.919547
18	6	0	-2.062381	0.251416	1.971154
19	1	0	-1.098142	0.764435	2.033296
20	1	0	-2.786594	0.821325	2.564148
21	1	0	-1.943736	-0.730478	2.440693
22	8	0	2.390160	2.172259	-0.758504
23	1	0	2.253639	0.502402	-1.841437
24	6	0	1.794591	3.089138	0.167767
25	1	0	1.532167	2.583259	1.100963
26	1	0	2.550117	3.850447	0.359471
27	1	0	0.904732	3.558728	-0.265157
28	16	0	1.889735	-2.200484	-0.343699
29	6	0	2.742511	-0.849872	0.248822
30	1	0	3.647967	-0.561756	-0.278518
31	6	0	2.591306	-0.317037	1.593204
32	1	0	3.309620	0.468668	1.834789
33	6	0	1.702895	-0.667697	2.544939
34	1	0	1.699007	-0.175528	3.511953
35	1	0	0.972387	-1.453825	2.382100

## Product1-IV



HF = -1269.3827537 hartrees

Imaginary Frequencies: none found

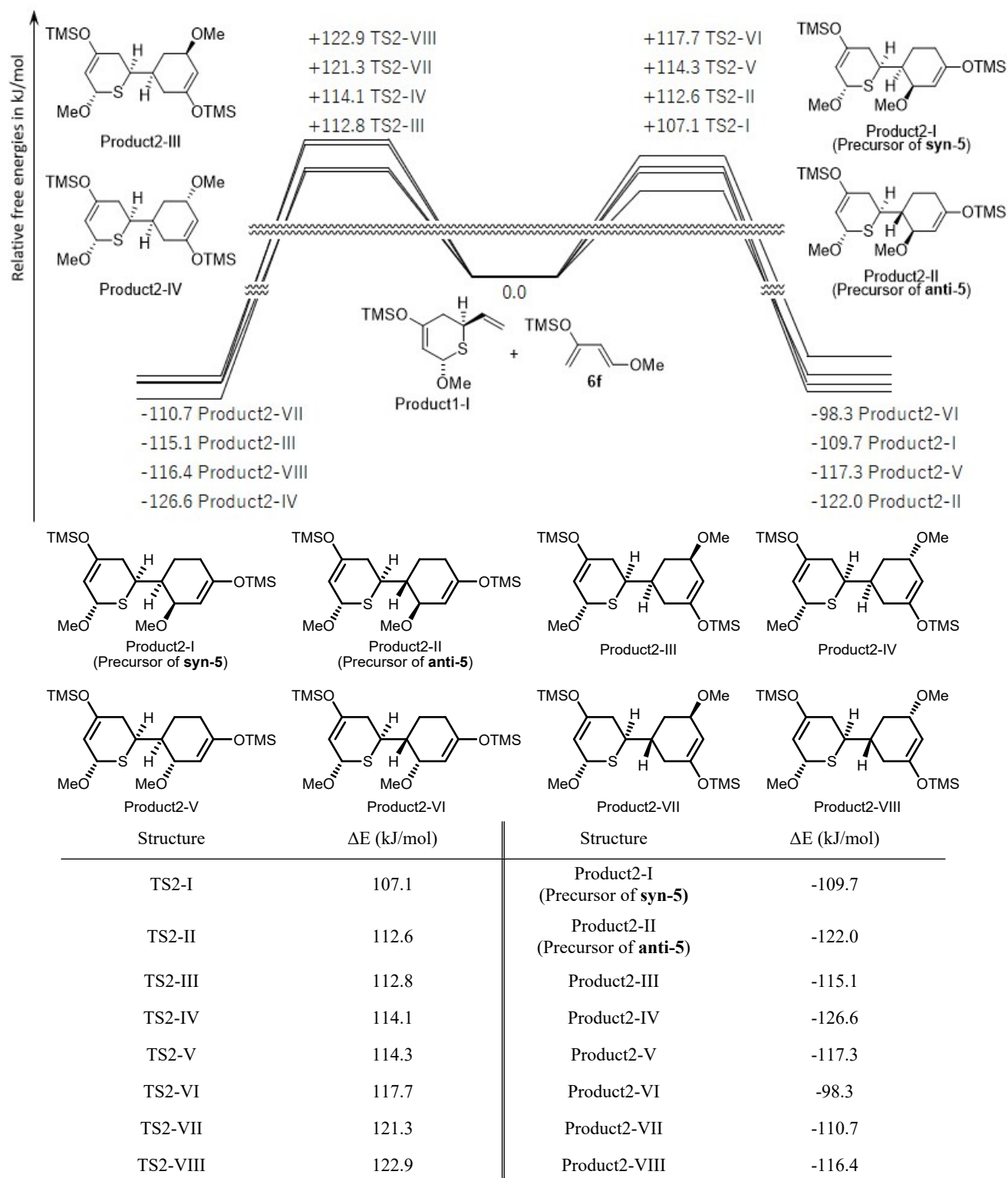
Zero-point correction = 0.289907 (Hartree/Particle)

Temperature: 298.150 Kelvin. Pressure: 1.00000 Atm.

Sum of electronic and zero-point Energies = -1269.092847 hartrees

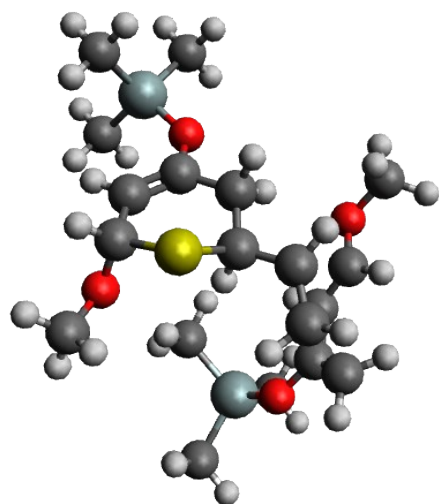
Coordinates:

Center Number	Atomic Number	Atomic Type	Coordinates (Angstroms)		
			X	Y	Z
1	6	0	1.833674	0.614282	-0.976919
2	6	0	0.350270	0.563856	-0.714342
3	1	0	-0.173948	1.467065	-0.433659
4	6	0	-0.286909	-0.614667	-0.805243
5	6	0	0.469499	-1.847004	-1.215171
6	1	0	-0.135765	-2.737558	-1.041367
7	1	0	0.732779	-1.809359	-2.276948
8	8	0	-1.608238	-0.846446	-0.577874
9	14	0	-2.799846	0.117334	0.175197
10	6	0	-3.145858	1.658250	-0.850805
11	1	0	-2.315158	2.370189	-0.850119
12	1	0	-3.361552	1.394026	-1.891485
13	1	0	-4.025169	2.176740	-0.451434
14	6	0	-4.302649	-1.005591	0.195255
15	1	0	-4.101183	-1.927537	0.749994
16	1	0	-5.151120	-0.504200	0.673848
17	1	0	-4.605981	-1.280221	-0.820239
18	6	0	-2.236454	0.546637	1.918078
19	1	0	-1.260435	1.040861	1.924579
20	1	0	-2.957211	1.217909	2.398182
21	1	0	-2.157784	-0.355820	2.533144
22	8	0	2.430651	1.910435	-0.941998
23	1	0	2.041224	0.257993	-1.995652
24	6	0	1.860012	2.915794	-0.113110
25	1	0	1.630332	2.556007	0.895829
26	1	0	2.610613	3.706750	-0.040439
27	1	0	0.950241	3.345581	-0.552782
28	16	0	2.027567	-2.093682	-0.233143
29	6	0	2.637066	-0.355489	-0.032070
30	1	0	3.660713	-0.356931	-0.421828
31	6	0	2.690251	0.116946	1.401166
32	1	0	3.308928	1.004046	1.533398
33	6	0	2.095433	-0.416176	2.468850
34	1	0	2.212045	0.031516	3.451288
35	1	0	1.489872	-1.313753	2.398058



**Figure S9.** DFT computed Gibbs free energies and producted structures for Diels–Alder reactions of product1-I and Danishefsky’s diene (**6f**).

TS2-I



HF = -2023.8416529 hartrees  
 Imaginary Frequencies: 1 (-492.4656 1/cm)  
 Zero-point correction = 0.516172 (Hartree/Particle)  
 Temperature: 298.150 Kelvin. Pressure: 1.00000 Atm.  
 Sum of electronic and zero-point Energies = -2023.325481 hartrees

Coordinates:

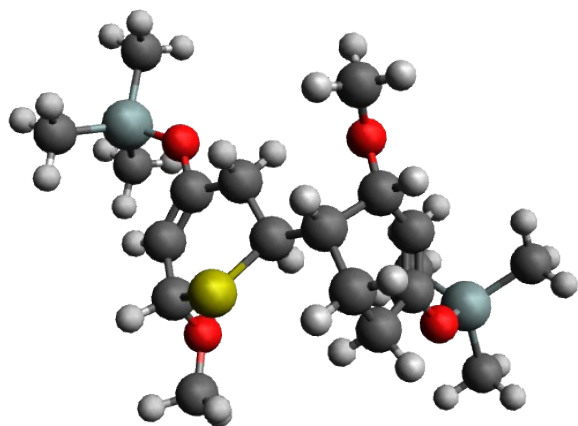
Center Number	Atomic Number	Atomic Type	Coordinates (Angstroms)		
			X	Y	Z
1	6	0	1.333673	2.095823	1.592862
2	6	0	2.205306	1.340571	0.632570
3	1	0	2.911155	1.963619	0.091216
4	6	0	2.169416	0.018536	0.395657
5	6	0	1.199088	-0.963548	1.002558
6	1	0	0.912519	-1.663117	0.210376
7	1	0	1.723805	-1.555683	1.766089
8	16	0	0.462164	1.003526	2.808063
9	6	0	-0.061300	-0.346280	1.600972
10	8	0	3.024772	-0.621322	-0.455117
11	14	0	4.477221	-0.138509	-1.203063
12	6	0	5.692153	0.488876	0.090608
13	1	0	5.326252	1.379348	0.609584
14	1	0	5.892431	-0.280872	0.843338
15	1	0	6.645423	0.746172	-0.384924
16	6	0	5.095701	-1.727133	-1.989605
17	1	0	4.371344	-2.119820	-2.710625
18	1	0	6.037354	-1.553407	-2.521993
19	1	0	5.274704	-2.499855	-1.234977
20	6	0	4.137218	1.156864	-2.527272
21	1	0	3.388866	0.796089	-3.240860
22	1	0	3.776842	2.103495	-2.113910
23	1	0	5.055970	1.367119	-3.086965
24	8	0	0.449044	2.912333	0.832223
25	1	0	1.958922	2.743568	2.225799
26	6	0	-0.115161	3.992495	1.564438
27	1	0	0.666667	4.652214	1.968582
28	1	0	-0.735479	4.559414	0.867334
29	1	0	-0.738327	3.636157	2.394256
30	6	0	-0.969917	-1.320267	2.285433

31	1	0	-0.513176	-2.208031	2.714645
32	6	0	-2.244175	-0.923083	2.713813
33	1	0	-2.450970	0.144255	2.729779
34	1	0	-2.684246	-1.459159	3.551011
35	1	0	-0.609984	0.194765	0.822617
36	6	0	-1.649139	-2.771511	0.203344
37	6	0	-2.303833	-1.752851	-0.456685
38	6	0	-3.341133	-1.020886	0.152259
39	6	0	-3.775442	-1.329027	1.450034
40	1	0	-3.844429	-2.378587	1.712091
41	1	0	-2.064102	-3.284606	1.061208
42	8	0	-0.615656	-3.396404	-0.416971
43	8	0	-3.810875	0.141634	-0.391771
44	14	0	-3.471236	0.998989	-1.820249
45	6	0	-4.002363	-0.029109	-3.306939
46	1	0	-3.842065	0.533752	-4.233630
47	1	0	-3.439939	-0.964815	-3.386183
48	1	0	-5.066540	-0.281094	-3.249329
49	6	0	-4.542066	2.532407	-1.653172
50	1	0	-5.598886	2.268000	-1.544679
51	1	0	-4.250597	3.125708	-0.780388
52	1	0	-4.444618	3.169530	-2.539136
53	6	0	-1.652421	1.471999	-1.943921
54	1	0	-1.278504	1.943359	-1.028621
55	1	0	-1.005839	0.617529	-2.165500
56	1	0	-1.528619	2.193099	-2.761159
57	6	0	-0.080157	-4.526570	0.276581
58	1	0	0.718676	-4.925250	-0.348736
59	1	0	0.329063	-4.228756	1.248175
60	1	0	-0.847763	-5.294634	0.423559
61	1	0	-4.581068	-0.720907	1.851083
62	1	0	-1.894210	-1.435493	-1.409897

---



## Product2-I



HF = -2023.9301441 hartrees

Imaginary Frequencies: none found

Zero-point correction = 0.522076 (Hartree/Particle)

Temperature: 298.150 Kelvin. Pressure: 1.00000 Atm.

Sum of electronic and zero-point Energies = -2023.408068 hartrees

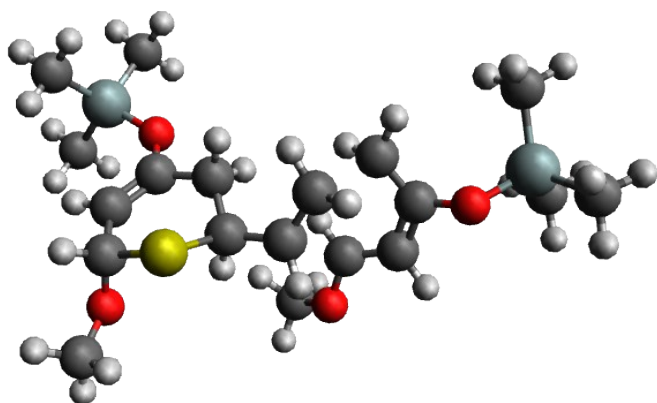
Coordinates:

Center Number	Atomic Number	Atomic Type	Coordinates (Angstroms)		
			X	Y	Z
1	6	0	-1.752833	-2.475977	0.138299
2	6	0	-2.584780	-1.316299	-0.321460
3	1	0	-3.320607	-1.568261	-1.079160
4	6	0	-2.468215	-0.048509	0.104752
5	6	0	-1.438142	0.462780	1.079397
6	1	0	-1.092206	1.430797	0.708319
7	1	0	-1.929749	0.655092	2.043658
8	16	0	-0.840169	-2.147157	1.718020
9	6	0	-0.224694	-0.447654	1.279410
10	8	0	-3.279311	0.968466	-0.308093
11	14	0	-4.787469	0.980474	-1.101420
12	6	0	-6.009819	-0.103319	-0.166617
13	1	0	-5.693577	-1.149780	-0.131327
14	1	0	-6.133161	0.246220	0.863809
15	1	0	-6.991914	-0.066221	-0.651486
16	6	0	-5.290257	2.787571	-1.024909
17	1	0	-4.555310	3.424190	-1.528231
18	1	0	-6.257691	2.940722	-1.515782
19	1	0	-5.381383	3.130173	0.010862
20	6	0	-4.598336	0.430580	-2.892790
21	1	0	-3.827599	1.018944	-3.401827
22	1	0	-4.331288	-0.626103	-2.988154
23	1	0	-5.541797	0.583654	-3.429600
24	8	0	-0.899926	-2.856269	-0.929694
25	1	0	-2.406185	-3.321196	0.401581
26	6	0	-0.402941	-4.185238	-0.833196
27	1	0	-1.222978	-4.917407	-0.803256
28	1	0	0.202092	-4.362959	-1.724568
29	1	0	0.221680	-4.319661	0.058779
30	6	0	0.773369	0.052718	2.353610
31	1	0	0.207606	0.247359	3.273868
32	6	0	1.883425	-0.973703	2.680891
33	1	0	1.456988	-1.888553	3.099669

34	1	0	2.521733	-0.543279	3.462030
35	1	0	0.293488	-0.562378	0.322778
36	6	0	1.539198	1.352563	1.964249
37	6	0	2.538143	1.104196	0.860131
38	6	0	3.090472	-0.098576	0.636917
39	6	0	2.742774	-1.315818	1.454606
40	1	0	3.673330	-1.806096	1.765343
41	1	0	2.074117	1.669124	2.878100
42	8	0	0.729214	2.459105	1.554128
43	8	0	4.014846	-0.377516	-0.329028
44	14	0	4.524082	0.509888	-1.689869
45	6	0	5.499320	2.030974	-1.156577
46	1	0	5.923298	2.529240	-2.036067
47	1	0	4.884371	2.763407	-0.625309
48	1	0	6.330664	1.751137	-0.500741
49	6	0	5.643560	-0.697520	-2.592406
50	1	0	6.486105	-1.002895	-1.963318
51	1	0	5.097480	-1.599403	-2.887336
52	1	0	6.052441	-0.240764	-3.500462
53	6	0	3.036693	0.973573	-2.745375
54	1	0	2.499019	0.078553	-3.075655
55	1	0	2.329042	1.609970	-2.206288
56	1	0	3.362706	1.516558	-3.639721
57	6	0	0.139625	3.174082	2.629223
58	1	0	-0.365049	4.040989	2.196680
59	1	0	-0.601144	2.576848	3.177415
60	1	0	0.901400	3.522541	3.341695
61	1	0	2.226270	-2.036499	0.806116
62	1	0	2.819982	1.976540	0.279872

---

TS2-II



HF = -2023.8380702 hartrees  
 Imaginary Frequencies: 1 (-490.0376 1/cm)  
 Zero-point correction = 0.515326 (Hartree/Particle)  
 Temperature: 298.150 Kelvin. Pressure: 1.00000 Atm.  
 Sum of electronic and zero-point Energies = -2023.322744 hartrees

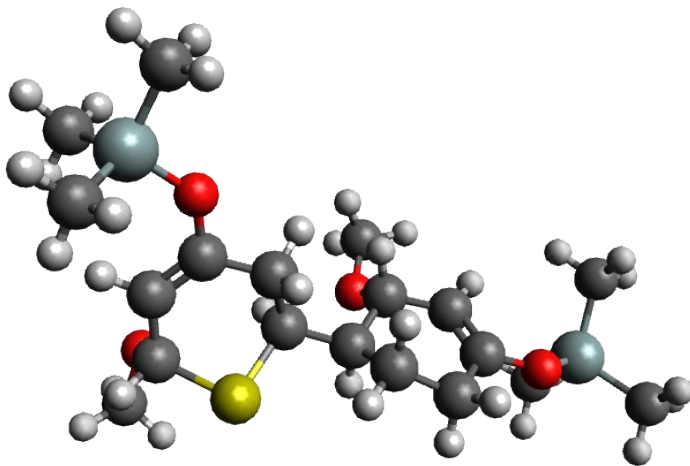
Coordinates:

Center Number	Atomic Number	Atomic Type	Coordinates (Angstroms)		
			X	Y	Z
1	6	0	-2.674588	2.565411	0.026107
2	6	0	-3.465196	1.291434	0.106062
3	1	0	-4.459285	1.413065	0.526200
4	6	0	-3.046750	0.069636	-0.263838
5	6	0	-1.675747	-0.265180	-0.793132
6	1	0	-1.394465	-1.244634	-0.393951
7	1	0	-1.735369	-0.391985	-1.883148
8	16	0	-1.176196	2.436334	-1.059139
9	6	0	-0.585701	0.751024	-0.461173
10	8	0	-3.826920	-1.049114	-0.203847
11	14	0	-5.515089	-1.260752	-0.097716
12	6	0	-6.371067	-0.247236	-1.432203
13	1	0	-6.194011	0.825816	-1.316333
14	1	0	-6.023060	-0.540435	-2.428204
15	1	0	-7.453381	-0.414679	-1.393880
16	6	0	-5.731162	-3.100635	-0.402037
17	1	0	-5.194942	-3.692216	0.347174
18	1	0	-6.789786	-3.378498	-0.352237
19	1	0	-5.355378	-3.385505	-1.390022
20	6	0	-6.130666	-0.808960	1.624182
21	1	0	-5.573238	-1.354371	2.393135
22	1	0	-6.043748	0.259808	1.841597
23	1	0	-7.187506	-1.082406	1.723881
24	8	0	-2.371051	2.969634	1.355036
25	1	0	-3.279857	3.346078	-0.459018
26	6	0	-2.033793	4.344661	1.479378
27	1	0	-2.851637	4.991019	1.128302
28	1	0	-1.859728	4.534749	2.540597
29	1	0	-1.125077	4.590487	0.915378
30	6	0	0.737995	0.401956	-1.070725
31	1	0	0.714241	-0.320577	-1.880195
32	6	0	1.889001	1.188452	-0.894858
33	1	0	1.740946	2.184644	-0.479892

34	1	0	2.626814	1.172212	-1.693187
35	1	0	-0.517645	0.877485	0.627078
36	6	0	1.378047	-1.730220	0.448788
37	6	0	2.705251	-1.773091	0.088075
38	6	0	3.562982	-0.661151	0.162952
39	6	0	3.085227	0.608278	0.539586
40	1	0	2.357377	0.641305	1.344258
41	1	0	0.964893	-0.983127	1.118980
42	8	0	0.588676	-2.814225	0.211414
43	8	0	4.786538	-0.819810	-0.432864
44	14	0	6.302728	-0.169380	-0.016547
45	6	0	-0.306847	-3.159465	1.274956
46	1	0	-0.974952	-3.928108	0.885091
47	1	0	0.248012	-3.554671	2.133349
48	1	0	-0.898138	-2.294131	1.596653
49	6	0	6.506735	-0.192701	1.854357
50	1	0	7.493702	0.194334	2.131631
51	1	0	5.754078	0.423143	2.356282
52	1	0	6.424330	-1.211744	2.246604
53	6	0	6.489010	1.575379	-0.701851
54	1	0	6.259494	1.603740	-1.772346
55	1	0	5.839572	2.298641	-0.198718
56	1	0	7.522937	1.917159	-0.574979
57	6	0	7.521239	-1.324659	-0.856695
58	1	0	7.426984	-2.346294	-0.474748
59	1	0	7.357480	-1.352485	-1.939021
60	1	0	8.551156	-0.993787	-0.683202
61	1	0	3.075164	-2.673726	-0.393737
62	1	0	3.804440	1.420750	0.591021

---

## Product2-II



HF = -2023.9332031 hartrees

Imaginary Frequencies: none found

Zero-point correction = 0.522240 (Hartree/Particle)

Temperature: 298.150 Kelvin. Pressure: 1.00000 Atm.

Sum of electronic and zero-point Energies = -2023.410963 hartrees

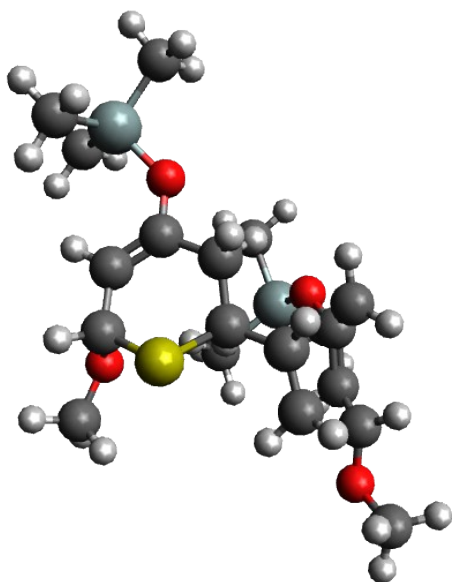
Coordinates:

Center Number	Atomic Number	Atomic Type	Coordinates (Angstroms)		
			X	Y	Z
1	6	0	-2.216245	2.285017	0.754930
2	6	0	-2.913374	0.960574	0.656231
3	1	0	-3.734938	0.834935	1.354828
4	6	0	-2.588570	-0.038543	-0.179320
5	6	0	-1.424868	-0.040041	-1.140071
6	1	0	-0.986918	-1.042647	-1.078168
7	1	0	-1.807755	0.067413	-2.164687
8	16	0	-1.168272	2.671808	-0.724623
9	6	0	-0.349786	1.014165	-0.863095
10	8	0	-3.274115	-1.214366	-0.263493
11	14	0	-4.816064	-1.683981	0.294387
12	6	0	-6.113057	-0.462429	-0.311039
13	1	0	-5.951345	0.545380	0.081944
14	1	0	-6.111985	-0.401930	-1.404409
15	1	0	-7.110626	-0.788650	0.004140
16	6	0	-5.054582	-3.370245	-0.494872
17	1	0	-4.272815	-4.069169	-0.180067
18	1	0	-6.021292	-3.797637	-0.206525
19	1	0	-5.029371	-3.304025	-1.587329
20	6	0	-4.819373	-1.833710	2.171561
21	1	0	-4.010867	-2.489428	2.511711
22	1	0	-4.704693	-0.869952	2.676548
23	1	0	-5.766243	-2.272846	2.506529
24	8	0	-1.491040	2.310034	1.973490
25	1	0	-2.958539	3.096921	0.753845
26	6	0	-1.157971	3.616718	2.426223
27	1	0	-2.058866	4.228687	2.577969
28	1	0	-0.640934	3.498999	3.380629
29	1	0	-0.496631	4.132284	1.718740
30	6	0	0.759235	1.071753	-1.939956
31	1	0	0.280660	1.289537	-2.902850

32	6	0	1.834384	2.144057	-1.670461
33	1	0	1.394155	3.143832	-1.631188
34	1	0	2.524536	2.126797	-2.519180
35	1	0	0.090533	0.818693	0.119230
36	6	0	1.488977	-0.278997	-2.113408
37	6	0	2.448309	-0.563487	-0.981228
38	6	0	2.959665	0.410185	-0.206500
39	6	0	2.612836	1.866088	-0.378249
40	1	0	2.041473	2.185876	0.504396
41	1	0	0.765276	-1.104341	-2.174919
42	8	0	2.135077	-0.194023	-3.402489
43	8	0	3.815683	0.217107	0.836425
44	14	0	4.400512	-1.195577	1.588374
45	6	0	2.744735	-1.400267	-3.821543
46	1	0	3.105444	-1.240272	-4.840786
47	1	0	3.597442	-1.679991	-3.187539
48	1	0	2.029446	-2.237792	-3.828118
49	6	0	5.472808	-2.178166	0.392028
50	1	0	5.926941	-3.029936	0.911334
51	1	0	4.907402	-2.570756	-0.458285
52	1	0	6.284896	-1.558086	-0.002155
53	6	0	2.963020	-2.221701	2.239831
54	1	0	2.352328	-1.638162	2.936818
55	1	0	2.308885	-2.580763	1.440108
56	1	0	3.341706	-3.096579	2.780494
57	6	0	5.438023	-0.525422	3.001911
58	1	0	6.251343	0.106908	2.631254
59	1	0	4.831488	0.072502	3.689788
60	1	0	5.885463	-1.345035	3.574944
61	1	0	2.723623	-1.598602	-0.807034
62	1	0	3.541030	2.449396	-0.356003

---

TS2-III



HF = -2023.8393261 hartrees  
 Imaginary Frequencies: 1 (-535.1374 1/cm)  
 Zero-point correction = 0.516040 (Hartree/Particle)  
 Temperature: 298.150 Kelvin. Pressure: 1.00000 Atm.  
 Sum of electronic and zero-point Energies = -2023.323286 hartrees

Coordinates:

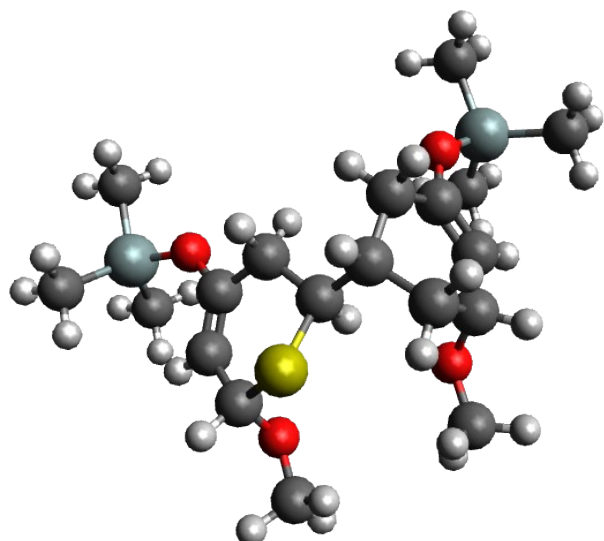
Center Number	Atomic Number	Atomic Type	Coordinates (Angstroms)		
			X	Y	Z
1	6	0	1.204836	-2.370505	1.305146
2	6	0	2.181870	-1.394137	0.722117
3	1	0	3.076519	-1.243648	1.318679
4	6	0	2.014336	-0.700276	-0.415186
5	6	0	0.796605	-0.735937	-1.304067
6	1	0	0.592326	0.300890	-1.586311
7	1	0	1.051606	-1.270094	-2.230305
8	16	0	-0.036987	-2.987939	0.075265
9	6	0	-0.462013	-1.337327	-0.681654
10	8	0	2.944825	0.159394	-0.922590
11	14	0	4.607482	0.363987	-0.607491
12	6	0	5.495200	-1.287881	-0.765994
13	1	0	5.361635	-1.708433	-1.768209
14	1	0	6.570164	-1.153388	-0.600862
15	1	0	5.134902	-2.023890	-0.041607
16	6	0	5.150037	1.555419	-1.952779
17	1	0	4.600756	2.500399	-1.889945
18	1	0	6.217867	1.782156	-1.859823
19	1	0	4.982080	1.132287	-2.948384
20	6	0	4.866732	1.134461	1.091556
21	1	0	4.276710	2.051130	1.197291
22	1	0	4.592272	0.462863	1.910497
23	1	0	5.921877	1.401658	1.221603
24	8	0	0.610208	-1.760856	2.443398
25	1	0	1.731402	-3.284511	1.617920
26	6	0	-0.001215	-2.675418	3.344741
27	1	0	0.723676	-3.414461	3.715891

28	1	0	-0.375867	-2.088450	4.185598
29	1	0	-0.837631	-3.207546	2.874760
30	6	0	-1.616317	-1.524293	-1.644144
31	1	0	-1.336102	-1.790394	-2.660715
32	6	0	-2.851319	-1.962414	-1.161606
33	1	0	-2.968103	-2.193539	-0.109076
34	1	0	-3.518196	-2.493923	-1.833423
35	1	0	-0.792025	-0.718968	0.159477
36	6	0	-1.948654	0.570925	-2.344589
37	6	0	-2.273926	1.191803	-1.140248
38	6	0	-3.400817	0.800928	-0.402034
39	6	0	-4.254102	-0.203294	-0.853167
40	1	0	-4.471672	-0.326919	-1.909393
41	1	0	-2.741124	0.201717	-2.981614
42	8	0	-5.237295	-0.617588	-0.002470
43	8	0	-1.327172	2.036959	-0.615284
44	14	0	-1.175511	2.861234	0.860290
45	6	0	-6.252380	-1.430374	-0.589793
46	1	0	-6.970054	-1.653183	0.200628
47	1	0	-6.762903	-0.900627	-1.403211
48	1	0	-5.836081	-2.368011	-0.974730
49	6	0	-2.566109	4.121716	1.029160
50	1	0	-3.552420	3.648037	1.057908
51	1	0	-2.446932	4.697891	1.953860
52	1	0	-2.557546	4.828111	0.192308
53	6	0	-1.158761	1.679975	2.329344
54	1	0	-2.136851	1.228249	2.521406
55	1	0	-0.435876	0.867882	2.196798
56	1	0	-0.872839	2.234572	3.231396
57	6	0	0.487611	3.717482	0.690466
58	1	0	1.291240	2.986806	0.550985
59	1	0	0.497455	4.398098	-0.167041
60	1	0	0.716954	4.303147	1.587502
61	1	0	-3.519906	1.122326	0.627415
62	1	0	-1.057317	0.897307	-2.868741

---



## Product2-III



HF = -2023.9324886 hartrees

Imaginary Frequencies: none found

Zero-point correction = 0.522418 (Hartree/Particle)

Temperature: 298.150 Kelvin. Pressure: 1.00000 Atm.

Sum of electronic and zero-point Energies = -2023.410070 hartrees

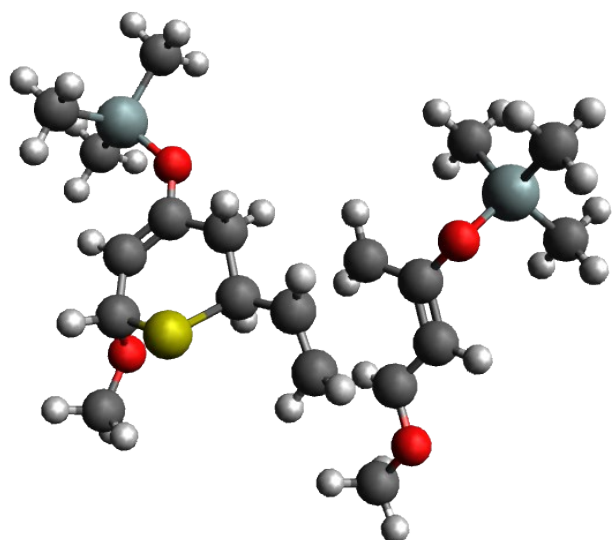
Coordinates:

Center Number	Atomic Number	Atomic Type	Coordinates (Angstroms)		
			X	Y	Z
1	6	0	2.707682	-2.100539	0.109323
2	6	0	3.030992	-0.638373	0.189138
3	1	0	3.920973	-0.413752	0.769194
4	6	0	2.326338	0.361338	-0.364050
5	6	0	1.032010	0.214709	-1.126033
6	1	0	0.398742	1.049858	-0.805354
7	1	0	1.230442	0.368658	-2.196528
8	16	0	1.467825	-2.505695	-1.206122
9	6	0	0.291857	-1.104011	-0.901591
10	8	0	2.692671	1.674022	-0.300739
11	14	0	4.140997	2.440375	0.169840
12	6	0	5.588093	1.733186	-0.804187
13	1	0	5.428893	1.853289	-1.880959
14	1	0	6.510284	2.264152	-0.542204
15	1	0	5.746654	0.669681	-0.604278
16	6	0	3.837200	4.235441	-0.287259
17	1	0	2.967688	4.637463	0.242841
18	1	0	4.703889	4.852111	-0.024721
19	1	0	3.659554	4.346471	-1.361801
20	6	0	4.398523	2.270829	2.027461
21	1	0	3.525312	2.639594	2.575976
22	1	0	4.578193	1.237842	2.339684
23	1	0	5.263537	2.867447	2.339470
24	8	0	2.326441	-2.536377	1.403663
25	1	0	3.599721	-2.659033	-0.212801
26	6	0	2.442579	-3.939056	1.600653
27	1	0	3.472497	-4.283972	1.427111
28	1	0	2.170172	-4.137262	2.639346

29	1	0	1.768055	-4.497187	0.939039
30	6	0	-0.943442	-1.306359	-1.819566
31	1	0	-0.563101	-1.503043	-2.830810
32	6	0	-1.816367	-2.503619	-1.390787
33	1	0	-1.225412	-3.422333	-1.343191
34	1	0	-2.577595	-2.662779	-2.164865
35	1	0	-0.008765	-1.184953	0.145390
36	6	0	-1.861922	-0.071037	-1.920400
37	6	0	-2.744335	0.112405	-0.711214
38	6	0	-3.047320	-0.887145	0.131932
39	6	0	-2.541916	-2.290580	-0.047974
40	1	0	-3.398415	-2.984950	-0.011078
41	1	0	-2.503842	-0.185422	-2.805399
42	8	0	-1.708030	-2.586407	1.093520
43	8	0	-3.206529	1.392757	-0.614548
44	14	0	-4.321234	2.124713	0.445580
45	6	0	-1.597674	-3.967910	1.388441
46	1	0	-0.993423	-4.054383	2.294671
47	1	0	-2.583806	-4.420654	1.574246
48	1	0	-1.104097	-4.535011	0.587005
49	6	0	-5.990486	1.261212	0.328653
50	1	0	-5.948241	0.220427	0.662318
51	1	0	-6.725536	1.782471	0.952488
52	1	0	-6.362847	1.269906	-0.701247
53	6	0	-3.651491	2.113887	2.205022
54	1	0	-3.537582	1.102710	2.606495
55	1	0	-2.673632	2.604801	2.251450
56	1	0	-4.330892	2.661753	2.868078
57	6	0	-4.434774	3.881544	-0.206789
58	1	0	-3.459041	4.377487	-0.180996
59	1	0	-4.795469	3.898441	-1.240384
60	1	0	-5.127944	4.474684	0.399897
61	1	0	-3.675818	-0.714262	0.999817
62	1	0	-1.300714	0.852140	-2.085617

-----

TS2-IV



HF = -2023.8383123 hartrees  
 Imaginary Frequencies: 1 (-534.5200 1/cm)  
 Zero-point correction = 0.515522 (Hartree/Particle)  
 Temperature: 298.150 Kelvin. Pressure: 1.00000 Atm.  
 Sum of electronic and zero-point Energies = -2023.322791 hartrees

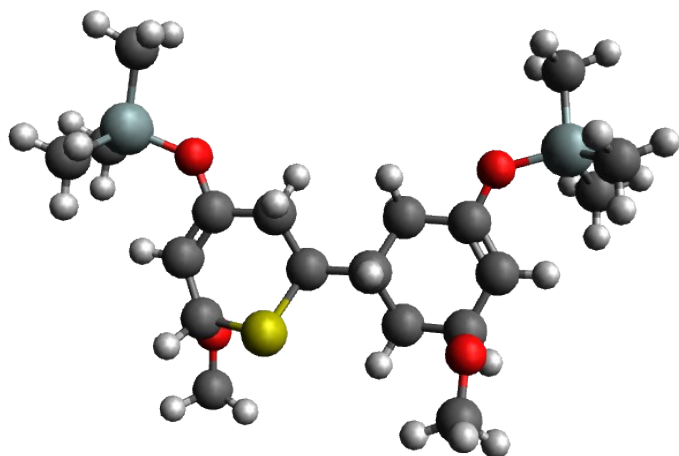
Coordinates:

Center Number	Atomic Number	Atomic Type	Coordinates (Angstroms)		
			X	Y	Z
1	6	0	3.272703	2.082073	0.480175
2	6	0	3.572480	0.667317	0.083800
3	1	0	4.588975	0.506611	-0.262756
4	6	0	2.706376	-0.358108	0.099957
5	6	0	1.246488	-0.281090	0.472186
6	1	0	0.714954	-0.918441	-0.241096
7	1	0	1.108621	-0.742506	1.459956
8	16	0	1.717386	2.253704	1.474277
9	6	0	0.632045	1.118275	0.464908
10	8	0	3.040165	-1.637095	-0.238925
11	14	0	4.543333	-2.437050	-0.334599
12	6	0	5.498975	-2.180040	1.265658
13	1	0	5.711218	-1.123866	1.455076
14	1	0	4.938538	-2.569754	2.121869
15	1	0	6.455972	-2.712049	1.222420
16	6	0	4.051401	-4.235183	-0.553627
17	1	0	3.451948	-4.373942	-1.459291
18	1	0	4.939713	-4.870530	-0.640171
19	1	0	3.464570	-4.592667	0.298598
20	6	0	5.517046	-1.841382	-1.832782
21	1	0	4.914104	-1.914215	-2.744147
22	1	0	5.857007	-0.805838	-1.737069
23	1	0	6.404716	-2.469554	-1.971141
24	8	0	3.271344	2.873309	-0.699163
25	1	0	4.052419	2.450220	1.163991
26	6	0	3.449788	4.264364	-0.465964
27	1	0	4.396344	4.464415	0.057013
28	1	0	3.473042	4.749700	-1.443882

29	1	0	2.625935	4.684013	0.125096
30	6	0	-0.771535	1.192729	1.032209
31	1	0	-0.960348	0.533768	1.874779
32	6	0	-1.496828	2.383585	0.950165
33	1	0	-1.025504	3.245943	0.487511
34	1	0	-2.234334	2.617449	1.708223
35	1	0	0.654939	1.528411	-0.551197
36	6	0	-1.860930	-0.314767	-0.312414
37	6	0	-3.197029	-0.068641	-0.015857
38	6	0	-3.783943	1.189352	-0.189782
39	6	0	-3.042015	2.289540	-0.618326
40	1	0	-2.238109	2.178998	-1.341371
41	1	0	-1.396906	0.194386	-1.148193
42	8	0	-3.668406	3.503026	-0.625116
43	8	0	-3.910257	-1.001650	0.719063
44	14	0	-4.734051	-2.331137	0.065478
45	6	0	-3.016889	4.524953	-1.377874
46	1	0	-3.627269	5.423266	-1.278350
47	1	0	-2.011925	4.727642	-0.989790
48	1	0	-2.945033	4.251208	-2.437367
49	6	0	-3.540208	-3.484388	-0.825693
50	1	0	-2.766745	-3.860128	-0.147514
51	1	0	-4.079604	-4.348719	-1.230088
52	1	0	-3.040668	-2.983336	-1.661064
53	6	0	-5.492020	-3.175007	1.562523
54	1	0	-4.719431	-3.502439	2.265989
55	1	0	-6.170846	-2.501646	2.095947
56	1	0	-6.065242	-4.058411	1.260140
57	6	0	-6.062147	-1.723173	-1.123780
58	1	0	-6.791879	-1.087201	-0.611637
59	1	0	-5.629117	-1.141719	-1.944555
60	1	0	-6.603338	-2.568502	-1.563689
61	1	0	-4.766706	1.370569	0.235499
62	1	0	-1.453454	-1.288939	-0.068242

---

## Product2-IV



HF = -2023.9363025 hartrees

Imaginary Frequencies: none found

Zero-point correction = 0.521835 (Hartree/Particle)

Temperature: 298.150 Kelvin. Pressure: 1.00000 Atm.

Sum of electronic and zero-point Energies = -2023.414468 hartrees

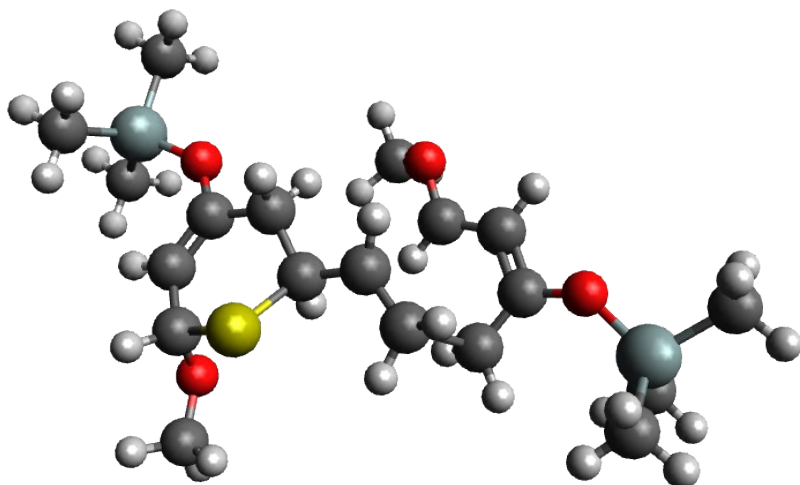
Coordinates:

Center Number	Atomic Number	Atomic Type	Coordinates (Angstroms)		
			X	Y	Z
1	6	0	-3.166240	2.119710	0.290508
2	6	0	-3.647000	0.701099	0.209194
3	1	0	-4.702030	0.575736	0.432909
4	6	0	-2.894655	-0.371558	-0.083951
5	6	0	-1.407031	-0.360427	-0.335988
6	1	0	-1.004725	-1.246215	0.168617
7	1	0	-1.226513	-0.507332	-1.410174
8	16	0	-1.525703	2.385710	-0.532039
9	6	0	-0.674163	0.890073	0.154305
10	8	0	-3.383903	-1.640113	-0.185644
11	14	0	-4.970682	-2.251547	-0.318282
12	6	0	-5.862938	-1.409397	-1.745136
13	1	0	-5.972680	-0.332245	-1.590434
14	1	0	-5.323718	-1.561216	-2.686051
15	1	0	-6.865975	-1.834808	-1.862970
16	6	0	-4.691774	-4.072866	-0.675829
17	1	0	-4.130934	-4.553495	0.132368
18	1	0	-5.648340	-4.597274	-0.777240
19	1	0	-4.131845	-4.213042	-1.606038
20	6	0	-5.893421	-2.037182	1.309194
21	1	0	-5.327310	-2.475513	2.137919
22	1	0	-6.088682	-0.988892	1.553935
23	1	0	-6.860061	-2.551523	1.258651
24	8	0	-3.178049	2.508674	1.654240
25	1	0	-3.840057	2.774276	-0.282027
26	6	0	-3.188408	3.916024	1.858539
27	1	0	-4.063662	4.382539	1.383697
28	1	0	-3.237429	4.079289	2.937004
29	1	0	-2.280003	4.387590	1.463234
30	6	0	0.823264	0.915852	-0.218451
31	1	0	0.904146	0.986643	-1.311838

32	6	0	1.570727	2.116969	0.381484
33	1	0	1.590214	2.026054	1.476071
34	1	0	1.053765	3.052996	0.154698
35	1	0	-0.775842	0.960524	1.244032
36	6	0	1.536467	-0.375952	0.224375
37	6	0	3.037187	-0.292957	0.096110
38	6	0	3.705570	0.857443	-0.080750
39	6	0	3.014187	2.189532	-0.135791
40	1	0	3.574158	2.911450	0.480945
41	1	0	1.285891	-0.610188	1.270302
42	8	0	3.067432	2.648545	-1.503784
43	8	0	3.608713	-1.529202	0.186896
44	14	0	5.233270	-2.020660	0.333134
45	6	0	2.964891	4.054951	-1.646204
46	1	0	3.078445	4.278879	-2.709967
47	1	0	1.993955	4.447613	-1.312201
48	1	0	3.756510	4.577868	-1.088008
49	6	0	6.019593	-1.202975	1.835616
50	1	0	5.469163	-1.453697	2.748575
51	1	0	7.049371	-1.556786	1.959642
52	1	0	6.048887	-0.113035	1.749106
53	6	0	5.094867	-3.877020	0.577155
54	1	0	4.521655	-4.116909	1.478536
55	1	0	4.599170	-4.352769	-0.275307
56	1	0	6.087971	-4.327917	0.681153
57	6	0	6.182051	-1.634619	-1.247015
58	1	0	5.685296	-2.077210	-2.116943
59	1	0	6.283107	-0.560697	-1.429339
60	1	0	7.191179	-2.058688	-1.188978
61	1	0	4.783052	0.860502	-0.210316
62	1	0	1.206311	-1.236409	-0.366703

---

TS2-V



HF = -2023.8389869 hartrees  
 Imaginary Frequencies: 1 (-512.4581 1/cm)  
 Zero-point correction = 0.515597 (Hartree/Particle)  
 Temperature: 298.150 Kelvin. Pressure: 1.00000 Atm.  
 Sum of electronic and zero-point Energies = -2023.323390 hartrees

Coordinates:

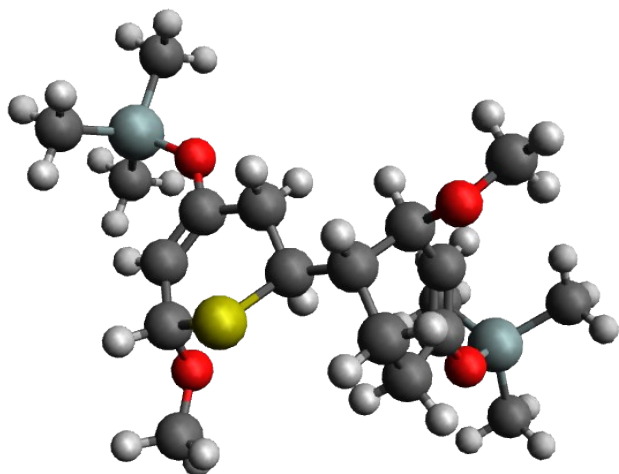
Center Number	Atomic Number	Atomic Type	Coordinates (Angstroms)		
			X	Y	Z
1	6	0	-3.436109	2.042521	-0.806187
2	6	0	-3.701676	0.630207	-0.370285
3	1	0	-4.740317	0.431725	-0.123000
4	6	0	-2.793673	-0.351715	-0.246239
5	6	0	-1.307927	-0.215536	-0.479212
6	1	0	-0.813193	-0.819617	0.291990
7	1	0	-1.062585	-0.685509	-1.439917
8	16	0	-1.786633	2.254480	-1.628901
9	6	0	-0.784522	1.218770	-0.426203
10	8	0	-3.102319	-1.629625	0.119414
11	14	0	-4.577475	-2.484727	0.162586
12	6	0	-5.437959	-2.357146	-1.505825
13	1	0	-5.691237	-1.325082	-1.764617
14	1	0	-4.804827	-2.758923	-2.303837
15	1	0	-6.367698	-2.937090	-1.493223
16	6	0	-4.032213	-4.246614	0.511997
17	1	0	-3.490080	-4.312796	1.460971
18	1	0	-4.899322	-4.913231	0.575339
19	1	0	-3.376339	-4.623442	-0.279391
20	6	0	-5.667713	-1.849714	1.560757
21	1	0	-5.126675	-1.859947	2.512909
22	1	0	-6.029213	-0.831145	1.391124
23	1	0	-6.544563	-2.498353	1.670410
24	8	0	-3.613048	2.883318	0.324157
25	1	0	-4.154382	2.329629	-1.588968
26	6	0	-3.828226	4.251318	0.002461
27	1	0	-4.716037	4.377705	-0.634339
28	1	0	-3.987612	4.777921	0.945666
29	1	0	-2.961637	4.686107	-0.511176
30	6	0	0.675919	1.412849	-0.720720

31	1	0	1.057986	2.391092	-0.450108
32	6	0	1.401704	0.646669	-1.642277
33	1	0	0.863627	-0.066320	-2.262790
34	1	0	2.224309	1.127666	-2.162749
35	1	0	-1.028891	1.652118	0.548703
36	6	0	1.683191	0.787425	1.527013
37	6	0	3.003666	0.743714	1.124542
38	1	0	3.689944	1.468858	1.552687
39	6	0	3.447585	-0.031855	0.042037
40	6	0	2.560736	-0.763457	-0.761841
41	1	0	2.981536	-1.304750	-1.604316
42	1	0	1.736377	-1.275341	-0.278339
43	8	0	4.724426	0.218352	-0.420567
44	14	0	6.059904	-0.815459	-0.250769
45	6	0	6.385658	-1.111058	1.580013
46	1	0	6.605383	-0.172914	2.100360
47	1	0	5.521940	-1.572224	2.070571
48	1	0	7.242670	-1.780177	1.716680
49	6	0	5.757451	-2.451835	-1.133443
50	1	0	5.563209	-2.300595	-2.200542
51	1	0	6.638882	-3.097115	-1.042363
52	1	0	4.905556	-2.992268	-0.708418
53	6	0	7.466791	0.131768	-1.056242
54	1	0	7.256768	0.330699	-2.112303
55	1	0	7.634351	1.092340	-0.558371
56	1	0	8.399166	-0.441071	-1.002676
57	1	0	0.993008	-0.034103	1.369075
58	8	0	1.302501	1.716670	2.442642
59	6	0	0.252402	1.321799	3.331153
60	1	0	0.599714	0.547709	4.025051
61	1	0	-0.032615	2.212291	3.892253
62	1	0	-0.618071	0.948690	2.780468

---



## Product2-V



HF = -2023.934742 hartrees

Imaginary Frequencies: none found

Zero-point correction = 0.521989 (Hartree/Particle)

Temperature: 298.150 Kelvin. Pressure: 1.00000 Atm.

Sum of electronic and zero-point Energies = -2023.412753 hartrees

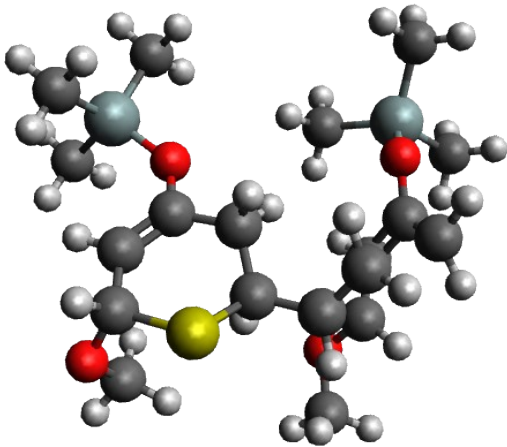
Coordinates:

Center Number	Atomic Number	Atomic Type	Coordinates (Angstroms)		
			X	Y	Z
1	6	0	3.024288	-2.295911	-0.375128
2	6	0	3.662279	-0.954202	-0.158984
3	1	0	4.726889	-1.000027	0.049315
4	6	0	3.038278	0.234964	-0.174684
5	6	0	1.558371	0.445394	-0.382865
6	1	0	1.254152	1.245277	0.303516
7	1	0	1.402785	0.833649	-1.397538
8	16	0	1.351647	-2.191924	-1.172423
9	6	0	0.706435	-0.800286	-0.136976
10	8	0	3.672379	1.430089	-0.004875
11	14	0	5.319924	1.870486	-0.019596
12	6	0	6.123622	1.292001	-1.619985
13	1	0	6.115777	0.202950	-1.721059
14	1	0	5.609903	1.714817	-2.489739
15	1	0	7.167517	1.623750	-1.655390
16	6	0	5.253728	3.744460	0.063396
17	1	0	4.745066	4.082802	0.971988
18	1	0	6.264643	4.166567	0.068943
19	1	0	4.721009	4.160843	-0.797625
20	6	0	6.199565	1.177230	1.494252
21	1	0	5.680187	1.467386	2.413701
22	1	0	6.274115	0.085819	1.481320
23	1	0	7.218242	1.578560	1.547468
24	8	0	3.008836	-2.974812	0.869382
25	1	0	3.613741	-2.875702	-1.100745
26	6	0	2.851177	-4.384251	0.762979
27	1	0	3.654995	-4.832092	0.160787
28	1	0	2.898277	-4.785581	1.777277
29	1	0	1.885309	-4.649138	0.315023
30	6	0	-0.809429	-0.630196	-0.372045
31	1	0	-1.253329	-1.631886	-0.291511

32	6	0	-1.196186	-0.049311	-1.741570
33	1	0	-0.882594	1.000181	-1.801932
34	1	0	-0.672552	-0.581370	-2.542375
35	1	0	0.840118	-1.124594	0.898665
36	6	0	-1.465531	0.197641	0.748278
37	6	0	-2.914651	0.505508	0.450952
38	1	0	-3.504762	0.885905	1.279000
39	6	0	-3.481219	0.328432	-0.752917
40	6	0	-2.710578	-0.132321	-1.962550
41	1	0	-3.011597	-1.162013	-2.202937
42	1	0	-3.013369	0.478943	-2.820873
43	8	0	-4.798377	0.555104	-1.040184
44	14	0	-6.173396	0.596410	-0.037213
45	6	0	-6.227181	-0.956594	1.024094
46	1	0	-6.300677	-1.853701	0.400460
47	1	0	-5.335172	-1.054874	1.649739
48	1	0	-7.101077	-0.935562	1.684845
49	6	0	-6.184942	2.156108	1.020327
50	1	0	-6.035610	3.048881	0.403750
51	1	0	-7.155425	2.256974	1.520092
52	1	0	-5.413807	2.150470	1.796653
53	6	0	-7.595555	0.637522	-1.262610
54	1	0	-7.537922	1.521090	-1.906771
55	1	0	-7.591200	-0.249400	-1.904382
56	1	0	-8.557126	0.668211	-0.738417
57	1	0	-0.908677	1.140014	0.891397
58	8	0	-1.342044	-0.570852	1.957763
59	6	0	-1.417020	0.196381	3.146304
60	1	0	-2.401379	0.665520	3.285445
61	1	0	-1.240716	-0.487378	3.980203
62	1	0	-0.652544	0.987304	3.167504

---

TS2-VI



HF = -2023.8379701 hartrees  
 Imaginary Frequencies: 1 (-515.4318 1/cm)  
 Zero-point correction = 0.516519 (Hartree/Particle)  
 Temperature: 298.150 Kelvin. Pressure: 1.00000 Atm.  
 Sum of electronic and zero-point Energies = -2023.321451 hartrees

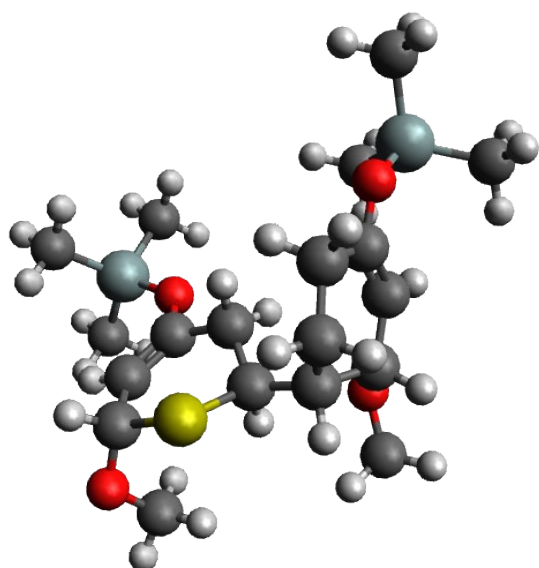
Coordinates:

Center Number	Atomic Number	Atomic Type	Coordinates (Angstroms)		
			X	Y	Z
1	6	0	-3.660910	-1.266560	0.562445
2	6	0	-3.102245	0.081315	0.195557
3	1	0	-3.852663	0.753005	-0.213063
4	6	0	-1.844217	0.524280	0.364635
5	6	0	-0.683705	-0.293696	0.876287
6	1	0	0.221538	0.078193	0.385589
7	1	0	-0.562339	-0.096888	1.949050
8	16	0	-2.426684	-2.392362	1.373774
9	6	0	-0.818733	-1.790502	0.614889
10	8	0	-1.452096	1.803469	0.092866
11	14	0	-2.336485	3.243094	-0.142328
12	6	0	-3.530007	3.504321	1.289183
13	1	0	-2.992727	3.534845	2.242902
14	1	0	-4.052192	4.460431	1.169970
15	1	0	-4.285798	2.716535	1.353492
16	6	0	-1.000976	4.562294	-0.151947
17	1	0	-0.271925	4.382576	-0.948789
18	1	0	-1.437734	5.553760	-0.314913
19	1	0	-0.461571	4.585732	0.800478
20	6	0	-3.228124	3.204093	-1.800863
21	1	0	-2.527607	2.985369	-2.613840
22	1	0	-4.028370	2.458928	-1.837366
23	1	0	-3.677298	4.183117	-2.004132
24	8	0	-4.387784	-1.865274	-0.504971
25	1	0	-4.425827	-1.142159	1.336475
26	6	0	-3.637494	-2.173823	-1.671673
27	1	0	-2.896022	-2.959153	-1.474678
28	1	0	-4.351770	-2.541116	-2.411852
29	1	0	-3.123065	-1.292222	-2.073689
30	6	0	0.283717	-2.663589	1.153024
31	1	0	0.143984	-3.723129	0.951168

32	6	0	1.145447	-2.317754	2.199333
33	1	0	1.010447	-1.367667	2.706394
34	1	0	1.488844	-3.113041	2.854368
35	1	0	-0.927234	-1.949774	-0.462677
36	6	0	1.721069	-2.574214	-0.856932
37	6	0	2.304876	-1.335038	-0.659448
38	6	0	2.986305	-1.011218	0.526009
39	6	0	3.092845	-1.928167	1.575885
40	1	0	3.263594	-2.968114	1.324944
41	1	0	2.088503	-3.478332	-0.386406
42	8	0	0.931571	-2.749997	-1.947534
43	8	0	3.304622	0.296348	0.805043
44	14	0	3.961247	1.514905	-0.174962
45	6	0	5.366699	0.801893	-1.204595
46	1	0	5.808121	1.579233	-1.838336
47	1	0	6.159729	0.398694	-0.566119
48	1	0	5.018891	-0.003892	-1.858893
49	6	0	4.582233	2.785407	1.060820
50	1	0	3.765811	3.157551	1.688576
51	1	0	5.345842	2.358135	1.718706
52	1	0	5.024450	3.644502	0.544318
53	6	0	2.641221	2.282967	-1.280794
54	1	0	2.352124	1.629384	-2.109996
55	1	0	1.737980	2.521040	-0.709112
56	1	0	3.017429	3.216575	-1.715438
57	6	0	0.586196	-4.106434	-2.243382
58	1	0	-0.070012	-4.077336	-3.113392
59	1	0	1.479929	-4.694764	-2.479686
60	1	0	0.057313	-4.569038	-1.402936
61	1	0	2.049507	-0.549167	-1.363149
62	1	0	3.594725	-1.595816	2.479879

---

## Product2-VI



HF = -2023.9262385 hartrees

Imaginary Frequencies: none found

Zero-point correction = 0.522527 (Hartree/Particle)

Temperature: 298.150 Kelvin. Pressure: 1.00000 Atm.

Sum of electronic and zero-point Energies = -2023.403711 hartrees

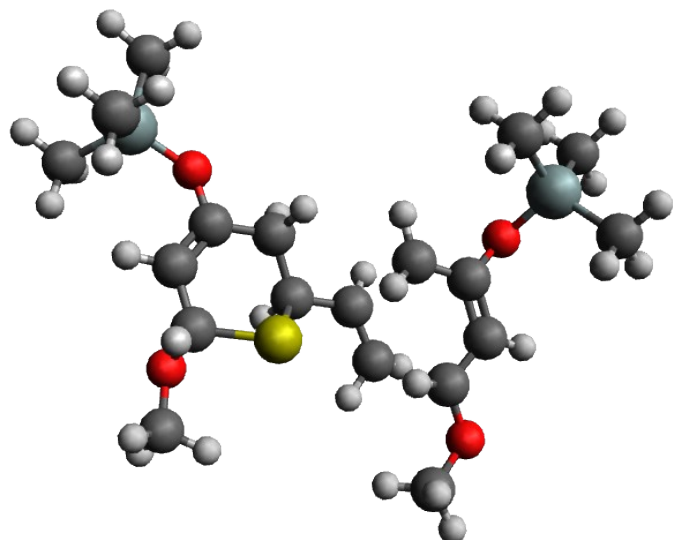
Coordinates:

Center Number	Atomic Number	Atomic Type	Coordinates (Angstroms)		
			X	Y	Z
1	6	0	3.442131	-1.386594	-1.079893
2	6	0	3.139223	-0.033252	-0.499819
3	1	0	4.028180	0.577751	-0.368216
4	6	0	1.934419	0.478249	-0.193914
5	6	0	0.619284	-0.257871	-0.274131
6	1	0	-0.007270	0.109256	0.543765
7	1	0	0.118371	0.022606	-1.207103
8	16	0	1.935040	-2.411177	-1.435613
9	6	0	0.763074	-1.773259	-0.144875
10	8	0	1.744685	1.757882	0.237463
11	14	0	2.745458	3.138716	0.218273
12	6	0	3.368390	3.452627	-1.529589
13	1	0	2.532369	3.579815	-2.225308
14	1	0	3.965783	4.371075	-1.554524
15	1	0	3.994990	2.636813	-1.901310
16	6	0	1.586827	4.504555	0.779430
17	1	0	1.191929	4.302259	1.780334
18	1	0	2.111184	5.465870	0.814253
19	1	0	0.738029	4.609553	0.096021
20	6	0	4.165655	2.941906	1.439593
21	1	0	3.790825	2.680417	2.434857
22	1	0	4.884032	2.173763	1.138153
23	1	0	4.711325	3.888417	1.528621
24	8	0	4.455552	-2.077593	-0.360888
25	1	0	3.888803	-1.264570	-2.072168
26	6	0	4.150370	-2.406999	0.987938
27	1	0	3.342758	-3.148288	1.045038
28	1	0	5.057421	-2.841410	1.413555

29	1	0	3.865613	-1.522935	1.571498
30	6	0	-0.517765	-2.647137	-0.174535
31	1	0	-0.154463	-3.664947	0.015714
32	6	0	-1.309843	-2.721207	-1.498350
33	1	0	-0.641019	-2.971742	-2.327188
34	1	0	-2.006350	-3.563505	-1.404778
35	1	0	1.238606	-1.965602	0.819502
36	6	0	-1.513134	-2.301244	0.968218
37	6	0	-2.464049	-1.185787	0.618295
38	6	0	-2.747924	-0.817062	-0.640035
39	6	0	-2.118142	-1.461243	-1.845667
40	1	0	-2.915036	-1.714090	-2.556067
41	1	0	-2.096978	-3.217676	1.170654
42	8	0	-0.862994	-1.930426	2.191043
43	8	0	-3.624024	0.169218	-0.993708
44	14	0	-4.473728	1.318975	-0.069210
45	6	0	-5.741800	0.465336	1.031449
46	1	0	-6.354090	1.214756	1.546119
47	1	0	-6.414782	-0.161642	0.436900
48	1	0	-5.280443	-0.167536	1.795243
49	6	0	-5.333682	2.361370	-1.372668
50	1	0	-4.609129	2.840651	-2.038953
51	1	0	-6.006361	1.753161	-1.986141
52	1	0	-5.930900	3.150842	-0.903177
53	6	0	-3.270939	2.360434	0.936723
54	1	0	-2.723918	1.769190	1.676725
55	1	0	-2.536402	2.846183	0.285711
56	1	0	-3.813564	3.147685	1.472490
57	6	0	-0.367065	-3.029969	2.938658
58	1	0	0.012888	-2.629569	3.881493
59	1	0	-1.161640	-3.759086	3.154702
60	1	0	0.452325	-3.554480	2.427496
61	1	0	-2.954248	-0.717754	1.465990
62	1	0	-1.499655	-0.713837	-2.359251

---

TS2-VII



HF = -2023.8355427 hartrees  
 Imaginary Frequencies: 1 (-549.5131 1/cm)  
 Zero-point correction = 0.515473 (Hartree/Particle)  
 Temperature: 298.150 Kelvin. Pressure: 1.00000 Atm.  
 Sum of electronic and zero-point Energies = -2023.320070 hartrees

Coordinates:

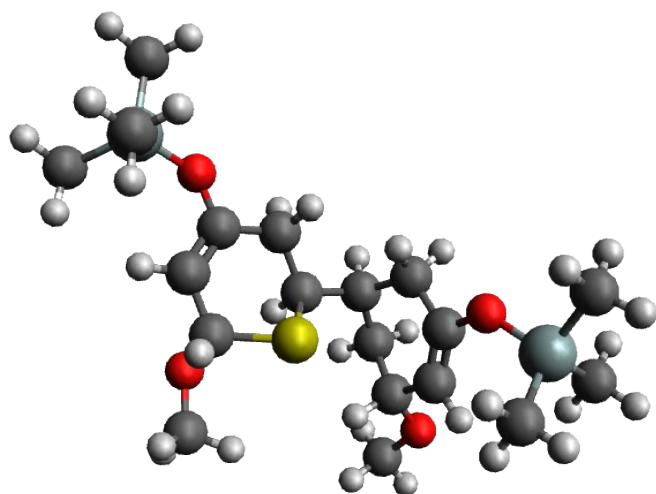
Center Number	Atomic Number	Atomic Type	Coordinates (Angstroms)		
			X	Y	Z
1	6	0	2.693417	2.045471	0.731826
2	6	0	3.370643	0.757155	0.361730
3	1	0	4.429283	0.731702	0.601649
4	6	0	2.799617	-0.300445	-0.239145
5	6	0	1.362369	-0.378354	-0.689903
6	1	0	1.354769	-0.878907	-1.666950
7	1	0	0.812778	-1.031881	-0.003023
8	16	0	0.841064	1.916804	0.767326
9	6	0	0.675995	0.979551	-0.823034
10	8	0	3.455365	-1.461104	-0.522007
11	14	0	4.959558	-2.086196	-0.015873
12	6	0	5.044884	-2.102174	1.864048
13	1	0	4.986631	-1.097655	2.292762
14	1	0	4.228022	-2.696612	2.286572
15	1	0	5.988907	-2.551837	2.192064
16	6	0	4.942824	-3.831390	-0.706058
17	1	0	4.845206	-3.825048	-1.796527
18	1	0	5.872883	-4.353766	-0.456299
19	1	0	4.110820	-4.412335	-0.295243
20	6	0	6.370929	-1.094668	-0.771318
21	1	0	6.268245	-1.038563	-1.860193
22	1	0	6.427379	-0.072044	-0.386627
23	1	0	7.326886	-1.584491	-0.552636
24	8	0	3.163782	3.054911	-0.144959
25	1	0	2.945501	2.313651	1.768315
26	6	0	2.980409	4.379892	0.339014
27	1	0	3.491584	4.527884	1.301173
28	1	0	3.415062	5.051343	-0.404047

29	1	0	1.917035	4.619790	0.463763
30	6	0	-0.758287	0.918479	-1.327499
31	1	0	-0.931805	0.095811	-2.015534
32	6	0	-1.507110	2.082507	-1.503971
33	1	0	-1.068788	3.033473	-1.215720
34	1	0	-2.241351	2.131581	-2.298442
35	1	0	1.257457	1.573142	-1.539892
36	6	0	-1.829634	-0.330829	0.253003
37	6	0	-3.164479	-0.194757	-0.115046
38	6	0	-3.798736	1.049270	-0.198694
39	6	0	-3.110607	2.240794	0.026671
40	1	0	-2.320605	2.306809	0.769173
41	1	0	-1.407491	0.334571	0.994962
42	8	0	-3.780958	3.405560	-0.216819
43	8	0	-3.823943	-1.277736	-0.676768
44	14	0	-4.641502	-2.473284	0.202636
45	6	0	-3.176916	4.581998	0.318081
46	1	0	-3.821369	5.417425	0.041721
47	1	0	-3.103155	4.527240	1.410896
48	1	0	-2.177222	4.742976	-0.101531
49	6	0	-6.030737	-1.681956	1.198650
50	1	0	-6.757434	-1.189047	0.544247
51	1	0	-6.565071	-2.437752	1.785370
52	1	0	-5.644740	-0.930748	1.895731
53	6	0	-5.318260	-3.625500	-1.117574
54	1	0	-5.993742	-3.096593	-1.797822
55	1	0	-4.510504	-4.061067	-1.714952
56	1	0	-5.878901	-4.449329	-0.662093
57	6	0	-3.458458	-3.386556	1.350084
58	1	0	-2.652302	-3.871311	0.789283
59	1	0	-3.001057	-2.711097	2.080113
60	1	0	-3.994618	-4.164590	1.905825
61	1	0	-4.773248	1.106312	-0.674958
62	1	0	-1.386009	-1.319168	0.206205

---



## Product2-VII



HF = -2023.9303045 hartrees

Imaginary Frequencies: none found

Zero-point correction = 0.521868 (Hartree/Particle)

Temperature: 298.150 Kelvin. Pressure: 1.00000 Atm.

Sum of electronic and zero-point Energies = -2023.408437 hartrees

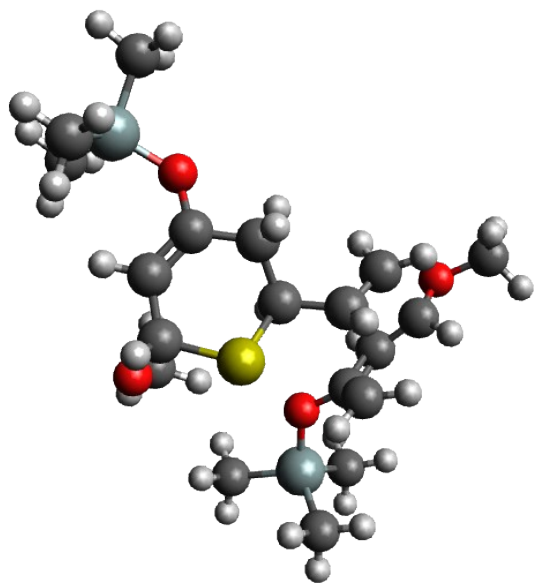
Coordinates:

Center Number	Atomic Number	Atomic Type	Coordinates (Angstroms)		
			X	Y	Z
1	6	0	1.841340	1.194101	1.602887
2	6	0	2.993435	0.540705	0.897976
3	1	0	3.941934	0.623476	1.419958
4	6	0	2.937790	-0.082094	-0.289971
5	6	0	1.710209	-0.202411	-1.156868
6	1	0	2.031166	-0.021109	-2.191053
7	1	0	1.360915	-1.243089	-1.123156
8	16	0	0.181881	0.633923	0.990259
9	6	0	0.572361	0.764629	-0.816077
10	8	0	4.003276	-0.692786	-0.882459
11	14	0	5.508038	-1.214633	-0.272192
12	6	0	5.237361	-2.302641	1.238919
13	1	0	4.743926	-1.765374	2.053887
14	1	0	4.621856	-3.172850	0.987934
15	1	0	6.199014	-2.670756	1.613877
16	6	0	6.222769	-2.201464	-1.699847
17	1	0	6.337575	-1.579176	-2.593346
18	1	0	7.210388	-2.597442	-1.438914
19	1	0	5.578967	-3.048476	-1.957853
20	6	0	6.609730	0.262056	0.118010
21	1	0	6.693134	0.926280	-0.748743
22	1	0	6.244846	0.855402	0.961669
23	1	0	7.618929	-0.084660	0.368846
24	8	0	2.020728	2.599830	1.521052
25	1	0	1.831391	0.888505	2.659570
26	6	0	1.297554	3.338115	2.497967
27	1	0	1.578127	3.034684	3.516998
28	1	0	1.554799	4.389610	2.354905
29	1	0	0.214042	3.212475	2.379163
30	6	0	-0.649330	0.569200	-1.749599

31	1	0	-0.194214	0.458357	-2.742505
32	6	0	-1.579597	1.795055	-1.849643
33	1	0	-0.981326	2.697699	-2.013736
34	1	0	-2.217219	1.667120	-2.732870
35	1	0	0.939386	1.787545	-0.954758
36	6	0	-1.472518	-0.712262	-1.489343
37	6	0	-2.667541	-0.515939	-0.590000
38	6	0	-3.140481	0.683724	-0.219919
39	6	0	-2.526887	1.983758	-0.655273
40	1	0	-1.981998	2.438109	0.188670
41	1	0	-0.850767	-1.502773	-1.054397
42	8	0	-3.617351	2.860740	-0.994140
43	8	0	-3.202728	-1.717914	-0.220792
44	14	0	-4.667819	-2.119130	0.546906
45	6	0	-3.267152	4.233629	-1.016807
46	1	0	-4.190836	4.797739	-1.169801
47	1	0	-2.811685	4.551980	-0.066610
48	1	0	-2.571315	4.481391	-1.830572
49	6	0	-6.117540	-1.417801	-0.428246
50	1	0	-6.125432	-1.809962	-1.450764
51	1	0	-7.063822	-1.702805	0.045442
52	1	0	-6.088452	-0.325979	-0.487792
53	6	0	-4.672880	-3.996321	0.499246
54	1	0	-4.645597	-4.367000	-0.530555
55	1	0	-3.808158	-4.408111	1.029796
56	1	0	-5.576990	-4.392582	0.974576
57	6	0	-4.668874	-1.510024	2.329154
58	1	0	-3.791303	-1.882587	2.868093
59	1	0	-4.669901	-0.418677	2.403948
60	1	0	-5.560343	-1.879849	2.848815
61	1	0	-3.998316	0.766933	0.440069
62	1	0	-1.835776	-1.117158	-2.443616

---

TS2-VIII



HF = -2023.8354093 hartrees  
 Imaginary Frequencies: 1 (-529.8103 1/cm)  
 Zero-point correction = 0.515966 (Hartree/Particle)  
 Temperature: 298.150 Kelvin. Pressure: 1.00000 Atm.  
 Sum of electronic and zero-point Energies = -2023.319444 hartrees

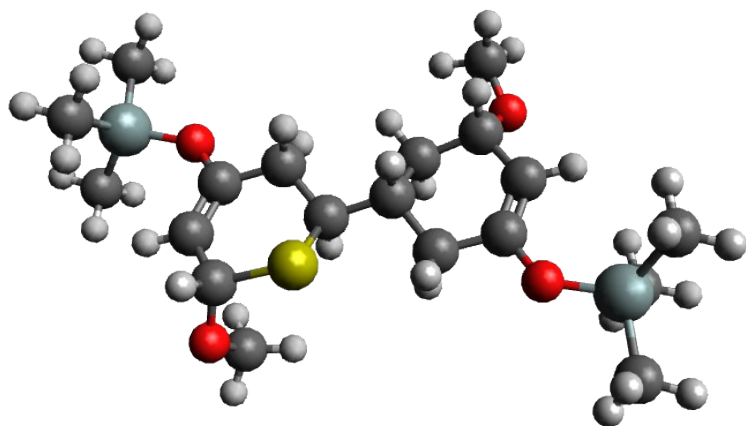
Coordinates:

Center Number	Atomic Number	Atomic Type	Coordinates (Angstroms)		
			X	Y	Z
1	6	0	-1.638725	-1.995424	1.207717
2	6	0	-2.702439	-1.217406	0.487007
3	1	0	-3.494017	-1.847239	0.090203
4	6	0	-2.772597	0.114467	0.332301
5	6	0	-1.733373	1.105111	0.793589
6	1	0	-1.732024	1.930710	0.074194
7	1	0	-2.045706	1.534749	1.754932
8	16	0	-0.324605	-0.949978	1.999643
9	6	0	-0.305340	0.550715	0.915483
10	8	0	-3.816331	0.756363	-0.267189
11	14	0	-5.384720	0.245387	-0.701064
12	6	0	-6.257917	-0.484422	0.797614
13	1	0	-5.759189	-1.381254	1.176093
14	1	0	-6.306862	0.244097	1.613700
15	1	0	-7.285487	-0.759425	0.534046
16	6	0	-6.208037	1.839713	-1.252029
17	1	0	-5.674513	2.290018	-2.095426
18	1	0	-7.239249	1.651408	-1.570537
19	1	0	-6.236398	2.572785	-0.439441
20	6	0	-5.307022	-0.978862	-2.129927
21	1	0	-4.736702	-0.564055	-2.967843
22	1	0	-4.848810	-1.932259	-1.850706
23	1	0	-6.319968	-1.191435	-2.490954
24	8	0	-1.125988	-3.065662	0.425635
25	1	0	-2.082471	-2.510525	2.066484
26	6	0	-0.460422	-2.691084	-0.775966
27	1	0	0.459423	-2.131409	-0.567550

28	1	0	-0.202558	-3.621362	-1.287127
29	1	0	-1.105488	-2.090321	-1.429276
30	6	0	0.639368	1.595041	1.493301
31	1	0	0.661113	1.642295	2.579942
32	6	0	0.842070	2.787675	0.797386
33	1	0	0.407721	2.930224	-0.186149
34	1	0	1.020169	3.698345	1.360020
35	1	0	0.048896	0.251463	-0.076766
36	6	0	2.613959	0.540167	1.508748
37	6	0	2.915484	0.456189	0.151785
38	6	0	3.036149	1.592079	-0.659487
39	6	0	2.900949	2.877148	-0.145953
40	1	0	3.244222	3.121204	0.854782
41	1	0	2.990238	1.378228	2.081333
42	8	0	2.883523	3.916828	-1.028812
43	8	0	2.846414	-0.772388	-0.487197
44	14	0	4.172493	-1.822459	-0.638004
45	6	0	3.077156	5.209534	-0.455669
46	1	0	3.043526	5.924225	-1.278760
47	1	0	2.284612	5.448866	0.262415
48	1	0	4.050538	5.278769	0.044614
49	6	0	4.793637	-2.348680	1.060664
50	1	0	4.010927	-2.863430	1.627615
51	1	0	5.642197	-3.035086	0.959333
52	1	0	5.127870	-1.490246	1.652086
53	6	0	3.496010	-3.289935	-1.595258
54	1	0	2.688130	-3.783913	-1.046277
55	1	0	3.103776	-2.981177	-2.569809
56	1	0	4.283961	-4.030691	-1.771138
57	6	0	5.546237	-0.963768	-1.600062
58	1	0	5.212654	-0.690261	-2.606704
59	1	0	5.879109	-0.049586	-1.097827
60	1	0	6.415075	-1.623887	-1.702194
61	1	0	3.036772	1.465998	-1.738281
62	1	0	2.471536	-0.377861	2.066673

-----

## Product2-VIII



HF = -2023.9324726 hartrees

Imaginary Frequencies: none found

Zero-point correction = 0.521895 (Hartree/Particle)

Temperature: 298.150 Kelvin. Pressure: 1.00000 Atm.

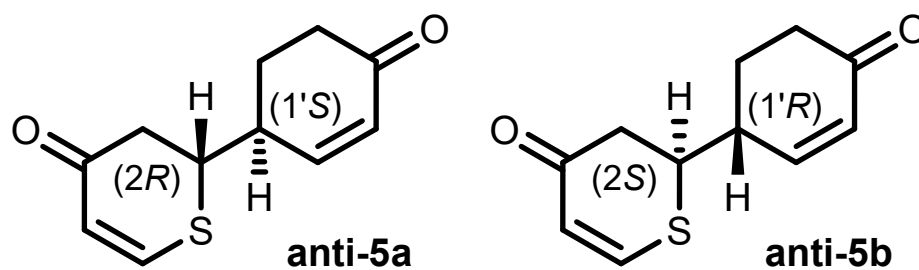
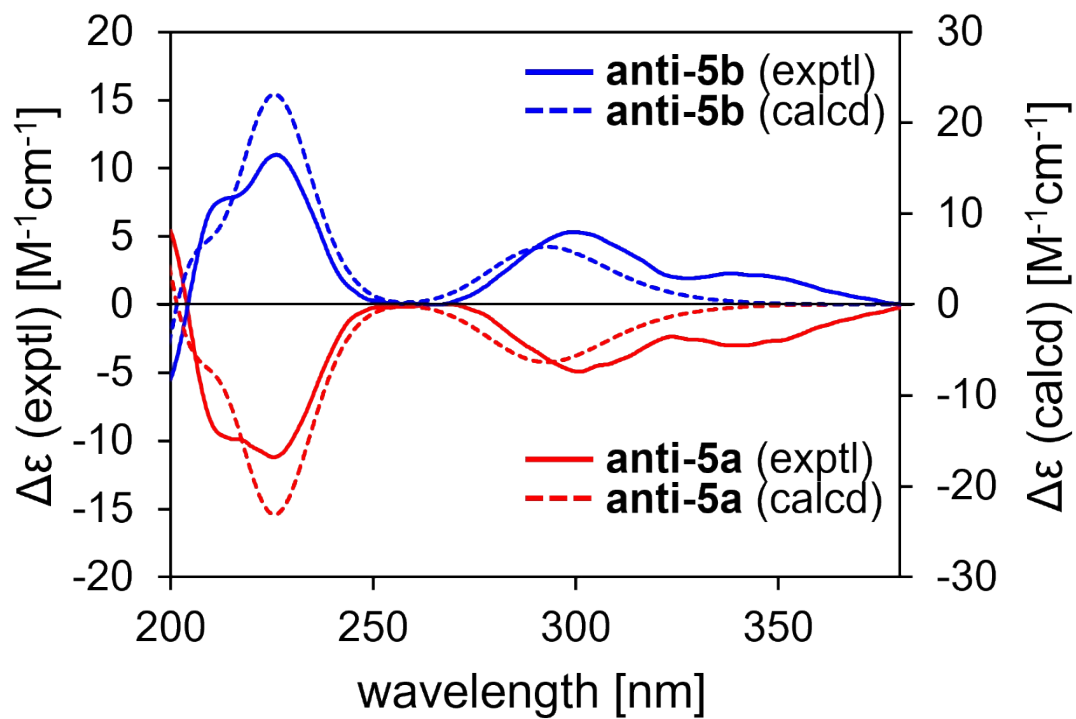
Sum of electronic and zero-point Energies = -2023.410578 hartrees

### Coordinates

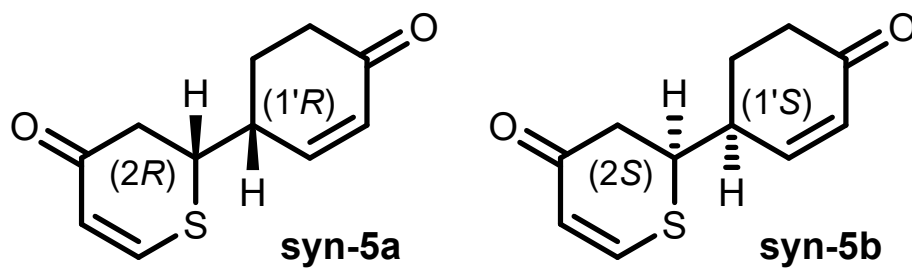
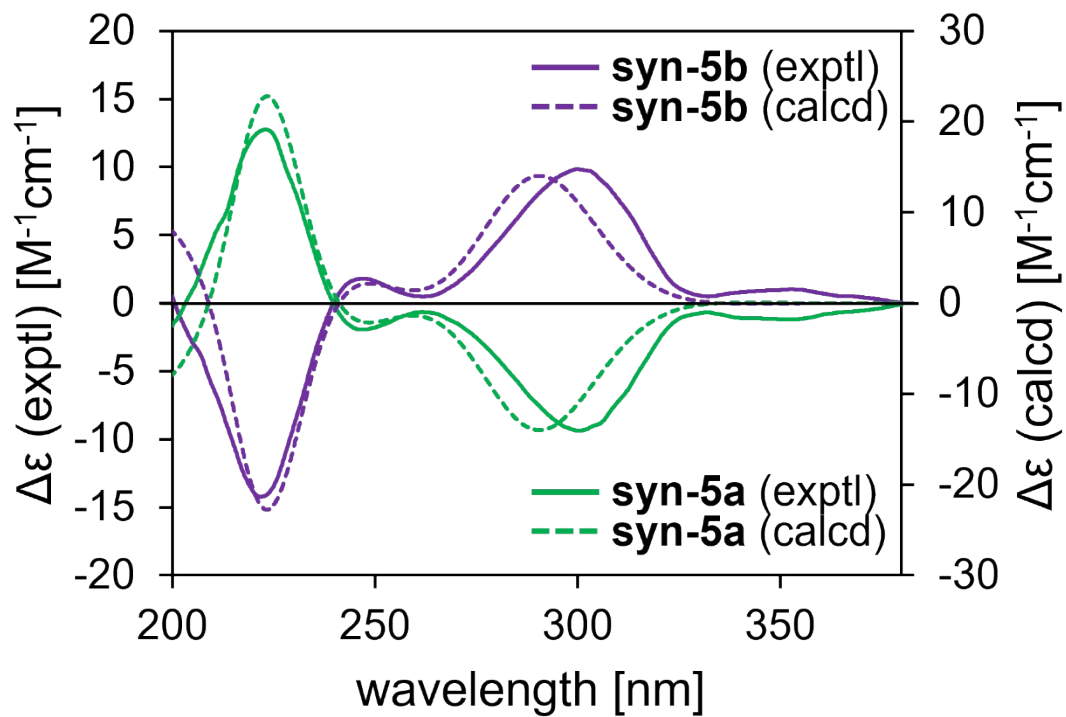
Center Number	Atomic Number	Atomic Type	Coordinates (Angstroms)		
			X	Y	Z
1	6	0	2.476972	-2.528829	-0.459730
2	6	0	3.429291	-1.412775	-0.139344
3	1	0	4.433536	-1.760844	0.086451
4	6	0	3.173409	-0.094619	-0.153649
5	6	0	1.825192	0.539562	-0.390741
6	1	0	1.797613	1.433903	0.240168
7	1	0	1.768163	0.889631	-1.430928
8	16	0	0.789681	-1.960424	-0.983153
9	6	0	0.624056	-0.351443	-0.070968
10	8	0	4.120765	0.863188	0.056755
11	14	0	5.825963	0.823448	-0.008692
12	6	0	6.382559	0.079909	-1.644892
13	1	0	6.063687	-0.959864	-1.760785
14	1	0	5.983446	0.651465	-2.489351
15	1	0	7.476046	0.103818	-1.712980
16	6	0	6.292071	2.637817	0.105446
17	1	0	5.926250	3.083236	1.036314
18	1	0	7.380737	2.758070	0.082348
19	1	0	5.873614	3.208124	-0.730090
20	6	0	6.519834	-0.124582	1.462822
21	1	0	6.124709	0.271798	2.404188
22	1	0	6.293074	-1.194307	1.426686
23	1	0	7.610528	-0.018547	1.490102
24	8	0	2.461518	-3.540996	0.537247
25	1	0	2.830582	-3.064606	-1.346968
26	6	0	2.005405	-3.141889	1.823565
27	1	0	0.939248	-2.881626	1.805508
28	1	0	2.147097	-4.000951	2.482608
29	1	0	2.574938	-2.289674	2.214194
30	6	0	-0.735588	0.288008	-0.439257
31	1	0	-0.736220	0.462895	-1.525219
32	6	0	-0.951465	1.643752	0.260292

33	1	0	-1.038117	1.491494	1.343964
34	1	0	-0.105465	2.313574	0.089437
35	1	0	0.623488	-0.579383	1.001013
36	6	0	-1.916639	-0.643530	-0.103417
37	6	0	-3.256986	0.042669	-0.183258
38	6	0	-3.403906	1.373709	-0.253237
39	6	0	-2.240029	2.323454	-0.227368
40	1	0	-2.066847	2.731920	-1.240362
41	1	0	-1.942337	-1.504350	-0.779534
42	8	0	-2.617091	3.417772	0.622802
43	8	0	-4.278848	-0.863818	-0.190201
44	14	0	-5.957555	-0.670183	0.022562
45	6	0	-1.836647	4.587823	0.445376
46	1	0	-2.298347	5.374142	1.047814
47	1	0	-0.797653	4.460542	0.779584
48	1	0	-1.823265	4.909943	-0.606983
49	6	0	-6.708497	0.230727	-1.451582
50	1	0	-6.457197	-0.277926	-2.388404
51	1	0	-7.801010	0.243655	-1.363436
52	1	0	-6.370363	1.268106	-1.531593
53	6	0	-6.585364	-2.438111	0.095365
54	1	0	-6.349566	-2.980743	-0.825907
55	1	0	-6.138061	-2.983482	0.932654
56	1	0	-7.673072	-2.456630	0.225514
57	6	0	-6.297941	0.235504	1.637134
58	1	0	-5.887233	-0.317576	2.488452
59	1	0	-5.864292	1.239623	1.648057
60	1	0	-7.378082	0.334536	1.793414
61	1	0	-4.384518	1.829520	-0.344752
62	1	0	-1.792817	-1.060517	0.906928

---



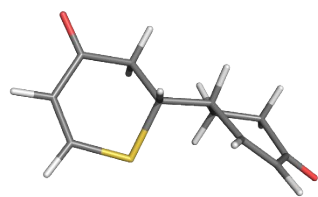
**Figure S10.** The calculated ECD spectra of **anti-5a** (red dash) and **anti-5b** (blue dash) and the measured ECD of **anti-5a** (red) and **anti-5b** (blue).



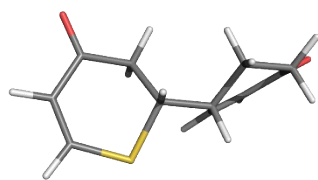
**Figure S11.** The calculated ECD spectra of **syn-5a** (green dash) and **syn-5b** (purple dash) and the measured ECD of **syn-5a** (green) and **syn-5b** (purple).



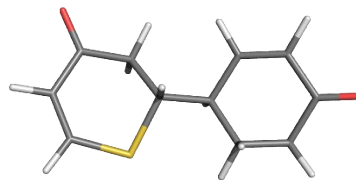
The DFT-optimized structures of conformers of **5** with their equilibrium population.



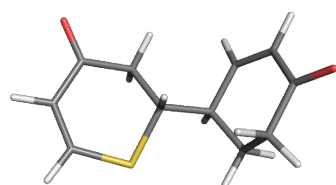
**Conf. 1**  
RE = 0.00 kJ/mol  
(49.41%)



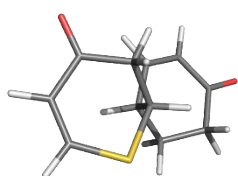
**Conf. 2**  
RE = 1.33 kJ/mol  
(28.85%)



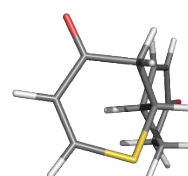
**Conf. 3**  
RE = 4.12 kJ/mol  
(9.38%)



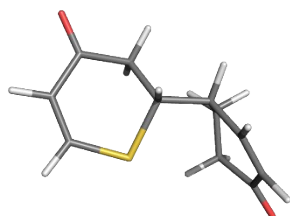
**Conf. 4**  
RE = 6.08 kJ/mol  
(4.25%)



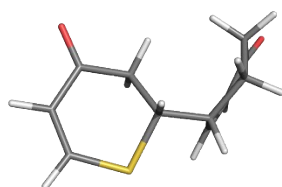
**Conf. 5**  
RE = 6.19 kJ/mol  
(4.07%)



**Conf. 6**  
RE = 7.70 kJ/mol  
(2.21%)

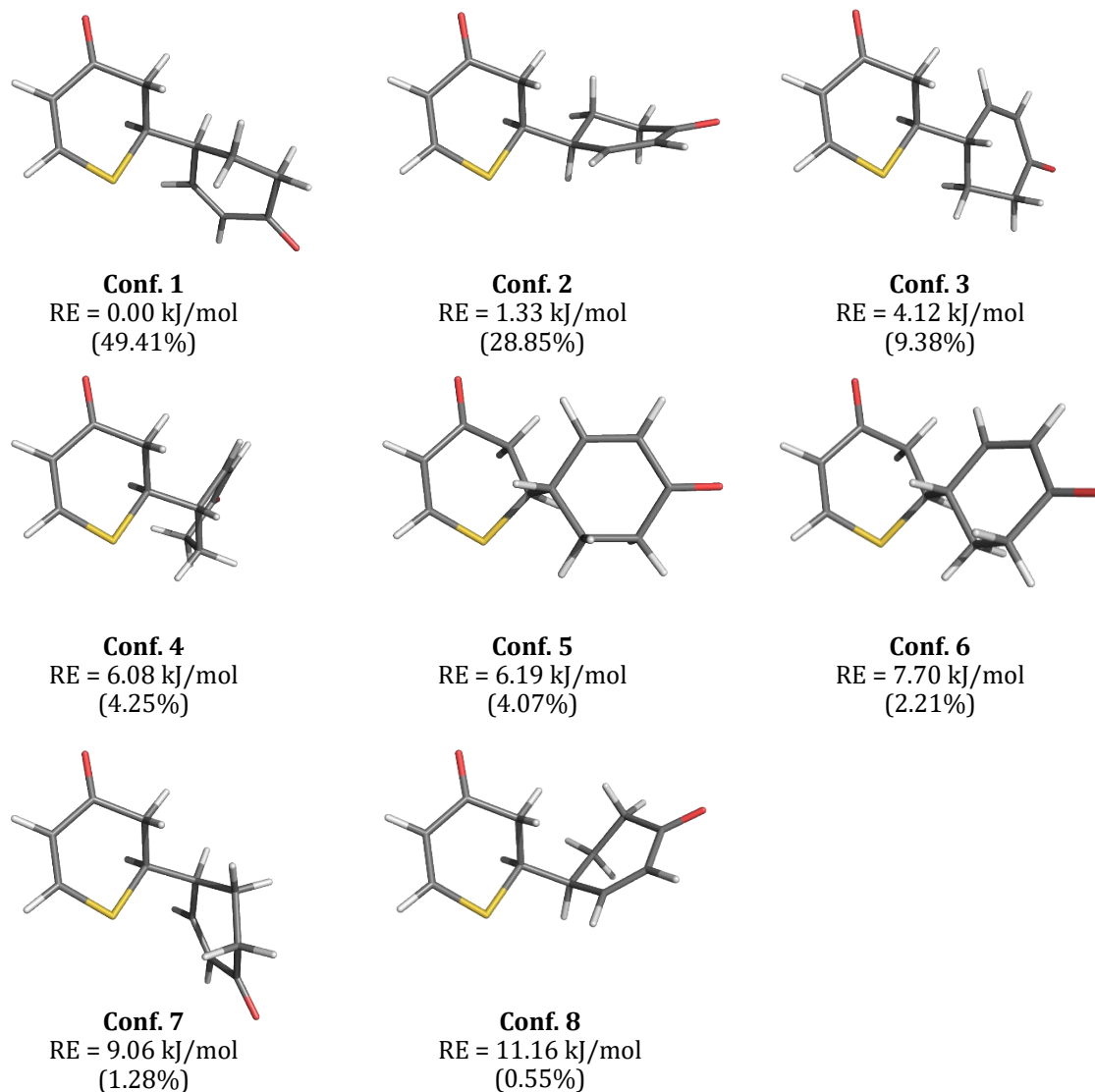


**Conf. 7**  
RE = 9.06 kJ/mol  
(1.28%)

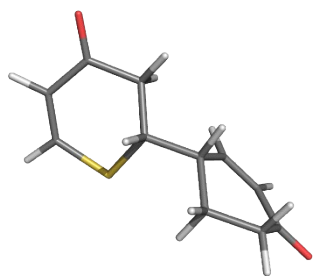


**Conf. 8**  
RE = 11.16 kJ/mol  
(0.55%)

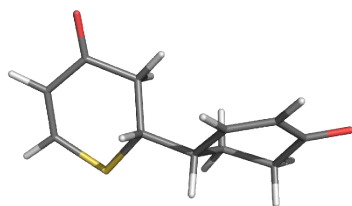
**Figure S12.** Optimized geometries, relative energies (REs), and Boltzmann distributions at 298.15 K of the 8 low-energy conformers of **syn-5a** calculated at the CAM-B3LYP/6-31G(d) level in MeCN.



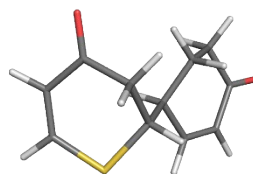
**Figure S13.** Optimized geometries, relative energies (REs), and Boltzmann distributions at 298.15 K of the 8 low-energy conformers of **syn-5b** calculated at the CAM-B3LYP/6-31G(d) level in MeCN.



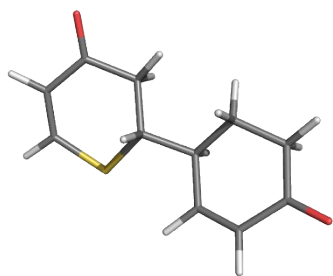
**Conf. 1**  
RE = 0.00 kJ/mol  
(35.12%)



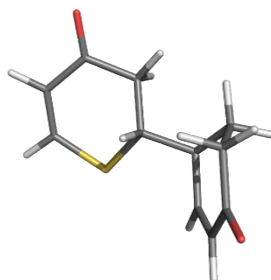
**Conf. 2**  
RE = 0.32 kJ/mol  
(30.90%)



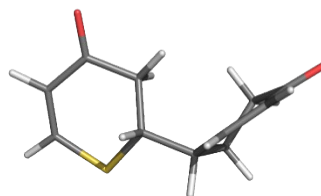
**Conf. 3**  
RE = 1.69 kJ/mol  
(17.74%)



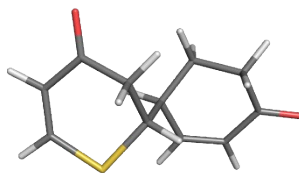
**Conf. 4**  
RE = 3.33 kJ/mol  
(9.15%)



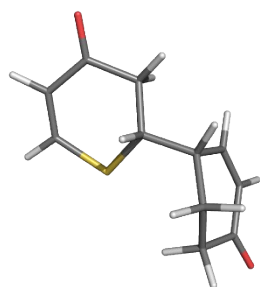
**Conf. 5**  
RE = 6.23 kJ/mol  
(2.84%)



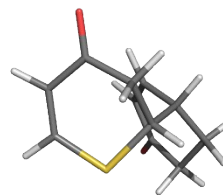
**Conf. 6**  
RE = 7.50 kJ/mol  
(1.71%)



**Conf. 7**  
RE = 7.87 kJ/mol  
(1.47%)

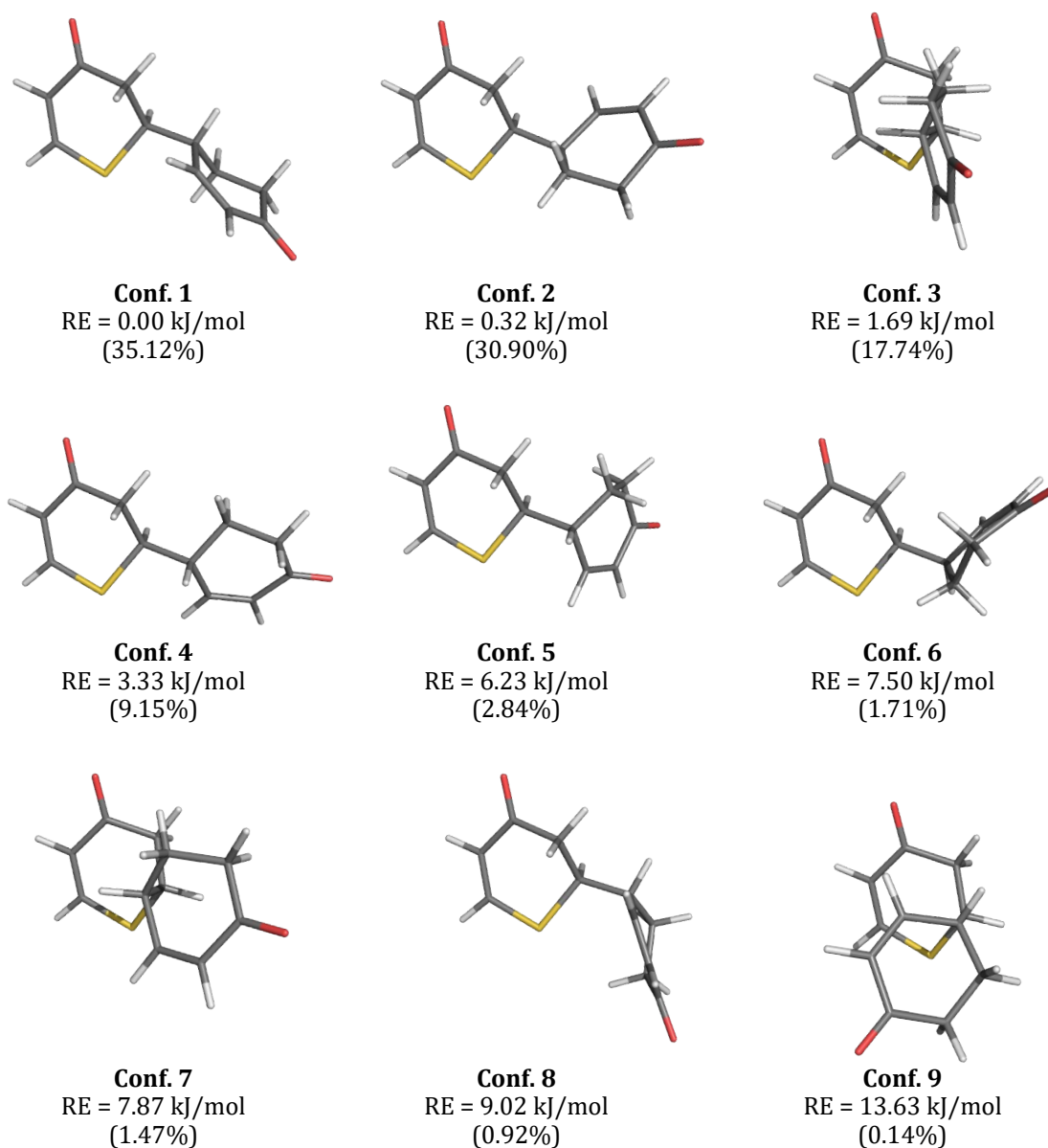


**Conf. 8**  
RE = 9.02 kJ/mol  
(0.92%)



**Conf. 9**  
RE = 13.62 kJ/mol  
(0.14%)

**Figure S14.** Optimized geometries, relative energies (REs), and Boltzmann distributions at 298.15 K of the 9 low-energy conformers of **anti-5a** calculated at the CAM-B3LYP/6-31G(d) level in MeCN.

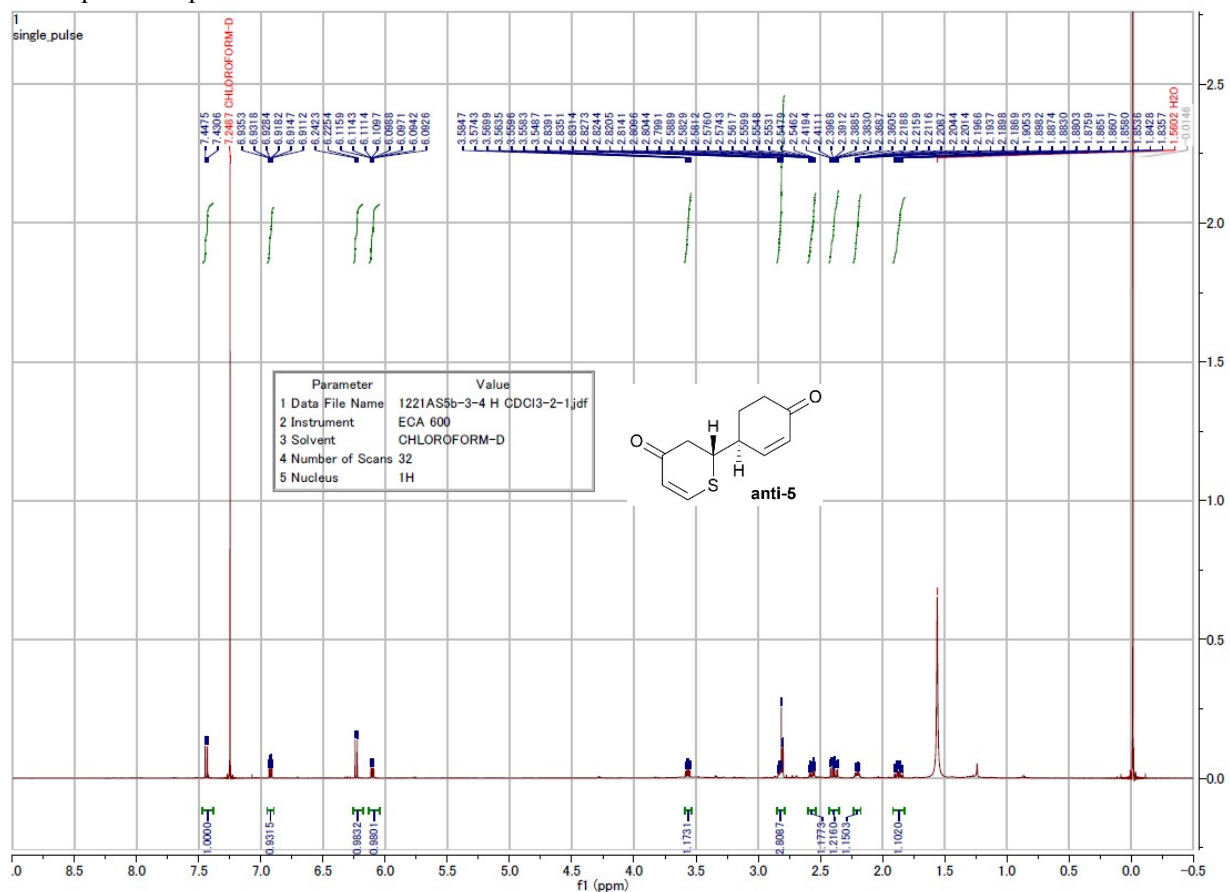


**Figure S15.** Optimized geometries, relative energies (REs), and Boltzmann distributions at 298.15 K of the 9 low-energy conformers of **anti-5b** calculated at the CAM-B3LYP/6-31G(d) level in MeCN.

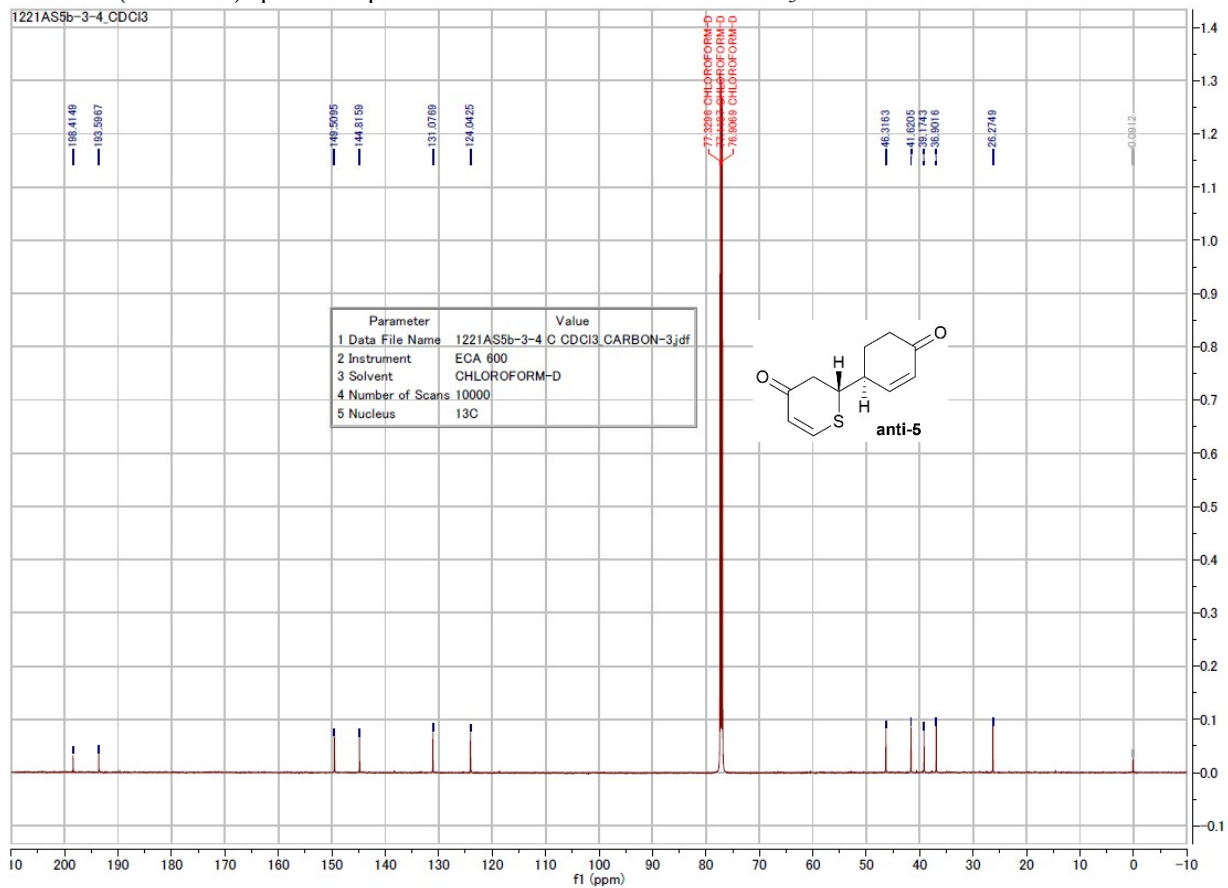
#### References

- [1] Wavefunction Inc.: Irvine, CA.
- [2] Frisch, M. J.; Trucks, G. W.; Schlegel, H. B.; Scuseria, G. E.; Robb, M. A.; Cheeseman, J. R.; Scalmani, G.; Barone, V.; Petersson, G. A.; Nakatsuji, H.; Li, X.; Caricato, M.; Marenich, A. V.; Bloino, J.; Janesko, B. G.; Gomperts, R.; Mennucci, B.; Hratchian, H. P.; Ortiz, J. V.; Izmaylov, A. F.; Sonnenberg, J. L.; Williams-Young, D.; Ding, F.; Lipparini, F.; Egidi, F.; Goings, J.; Peng, B.; Petrone, A.; Henderson, T.; Ranasinghe, D.; Zakrzewski, V. G.; Gao, J.; Rega, N.; Zheng, G.; Liang, W.; Hada, M.; Ehara, M.; Toyota, K.; Fukuda, R.; Hasegawa, J.; Ishida, M.; Nakajima, T.; Honda, Y.; Kitao, O.; Nakai, H.; Vreven, T.; Throssell, K.; Montgomery, Jr., J. A.; Peralta, J. E.; Ogliaro, F.; Bearpark, M. J.; Heyd, J. J.; Brothers, E. N.; Kudin, K. N.; Staroverov, V. N.; Keith, T. A.; Kobayashi, R.; Normand, J.; Raghavachari, K.; Rendell, A. P.; Burant, J. C.; Iyengar, S. S.; Tomasi, J.; Cossi, M.; Millam, J. M.; Klene, M.; Adamo, C.; Cammi, R.; Ochterski, J. W.; Martin, R. L.; Morokuma, K.; Farkas, O.; Foresman, J. B.; Fox, D. J. *Gaussian 16, Revision A.03*; Gaussian, Inc.: Wallingford, CT, 2016.
- [3] Bruhn, T.; Schaumlöffel, A.; Hemberger, Y.; Pecitelli, G. SpecDis: Quantifying the comparison of calculated and experimental electronic circular dichroism spectra. *Chirality*, 25, 243–249, 2013.

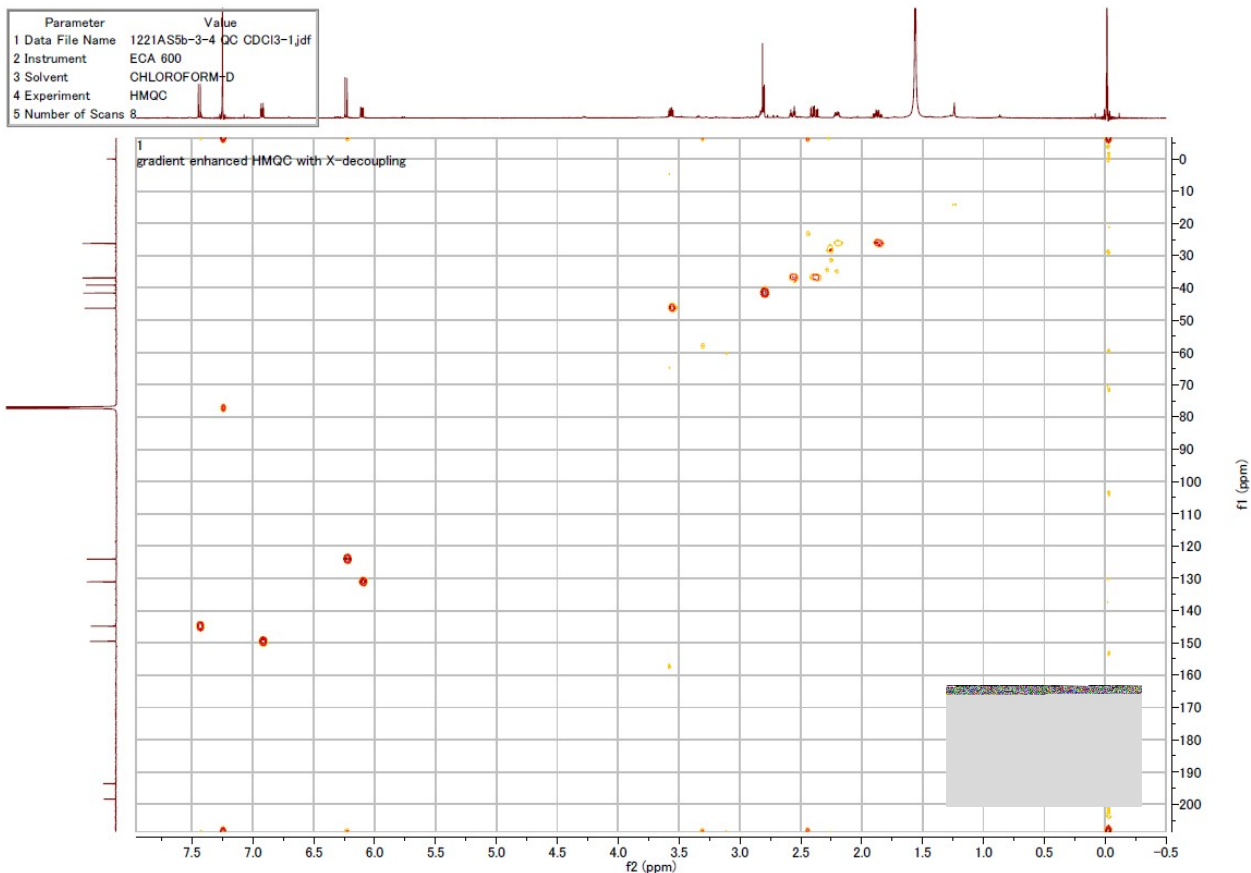
NMR spectroscopic data of synthesized compounds  
 NMR spectroscopic data of **anti-5**



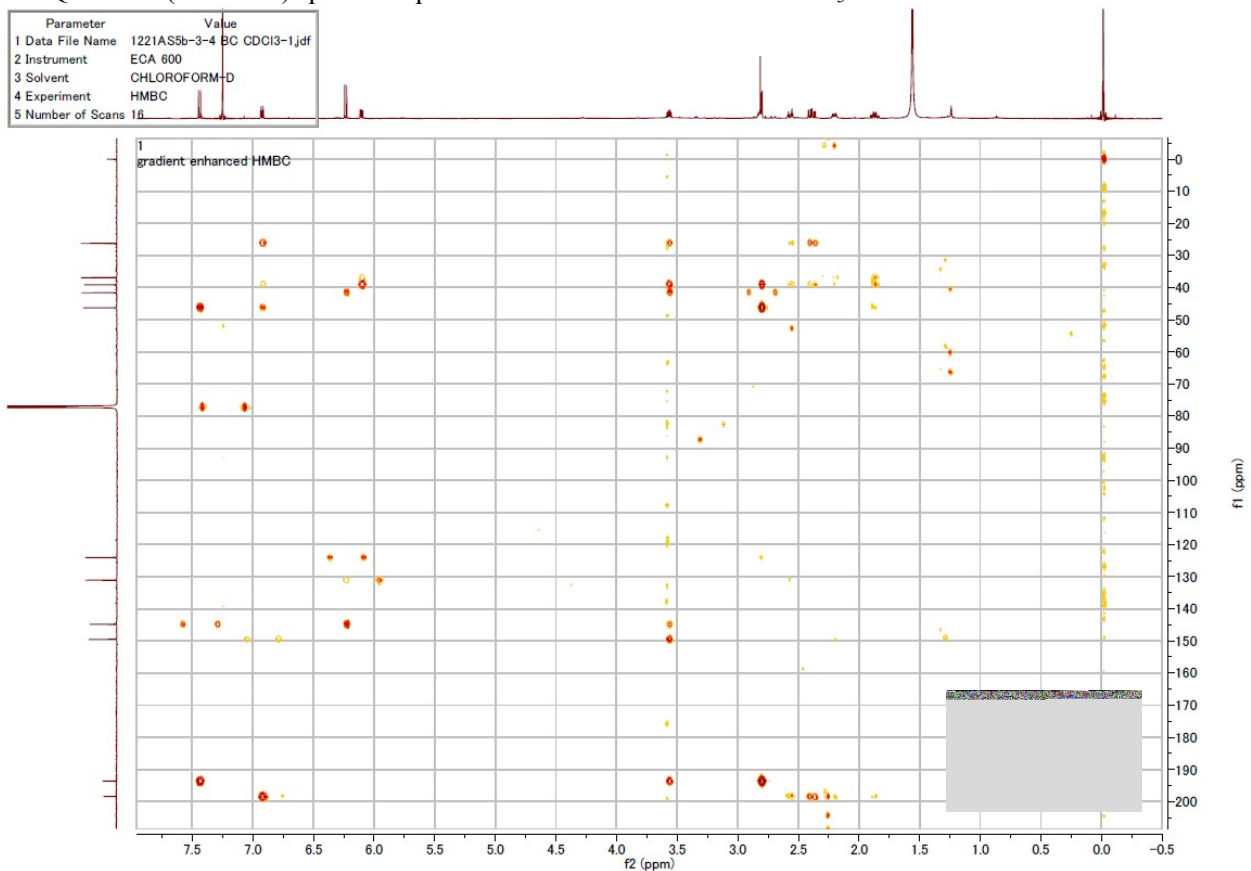
<sup>1</sup>H-NMR (600 MHz) spectroscopic data of **anti-5**. Measured in CDCl<sub>3</sub>.



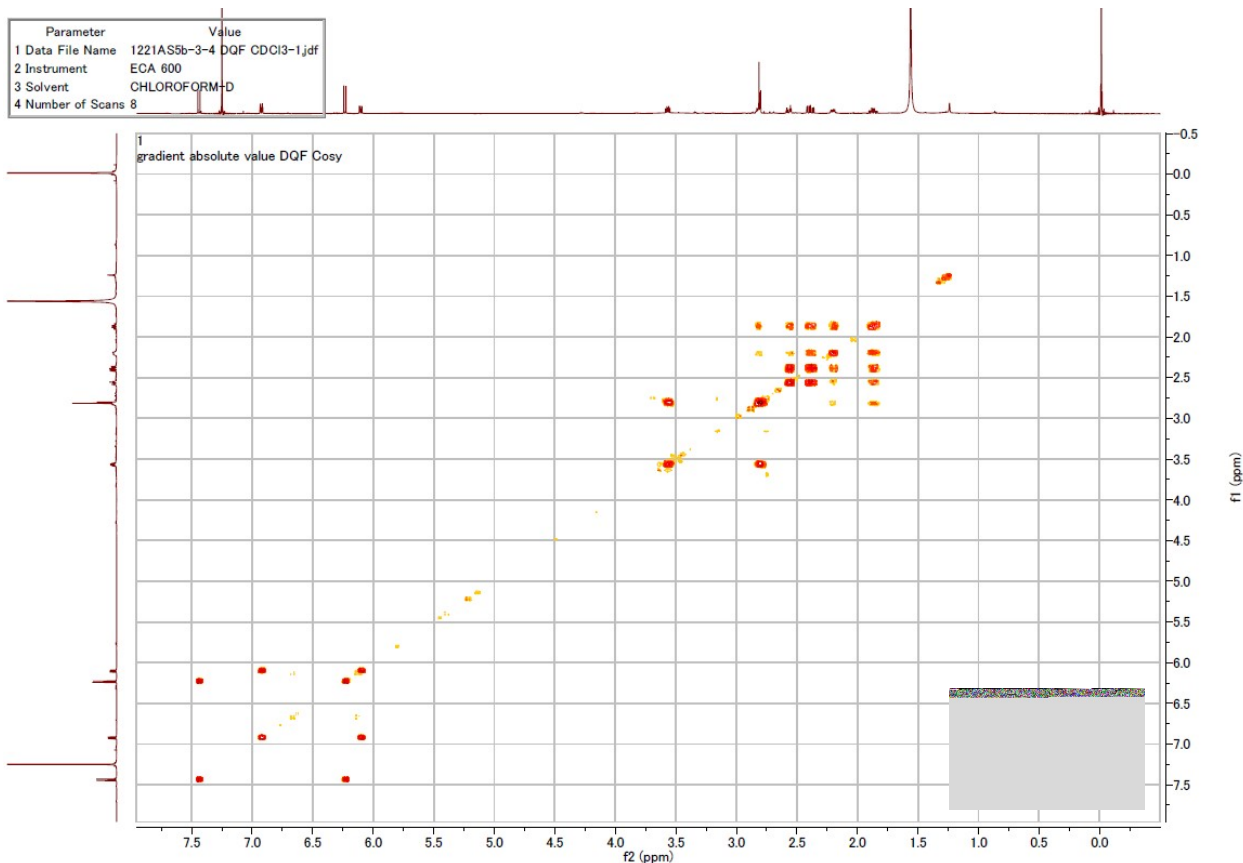
<sup>13</sup>C-NMR (150 MHz) spectroscopic data of **anti-5**. Measured in CDCl<sub>3</sub>.



HMQC NMR (600 MHz) spectroscopic data of **anti-5**. Measured in  $\text{CDCl}_3$ .

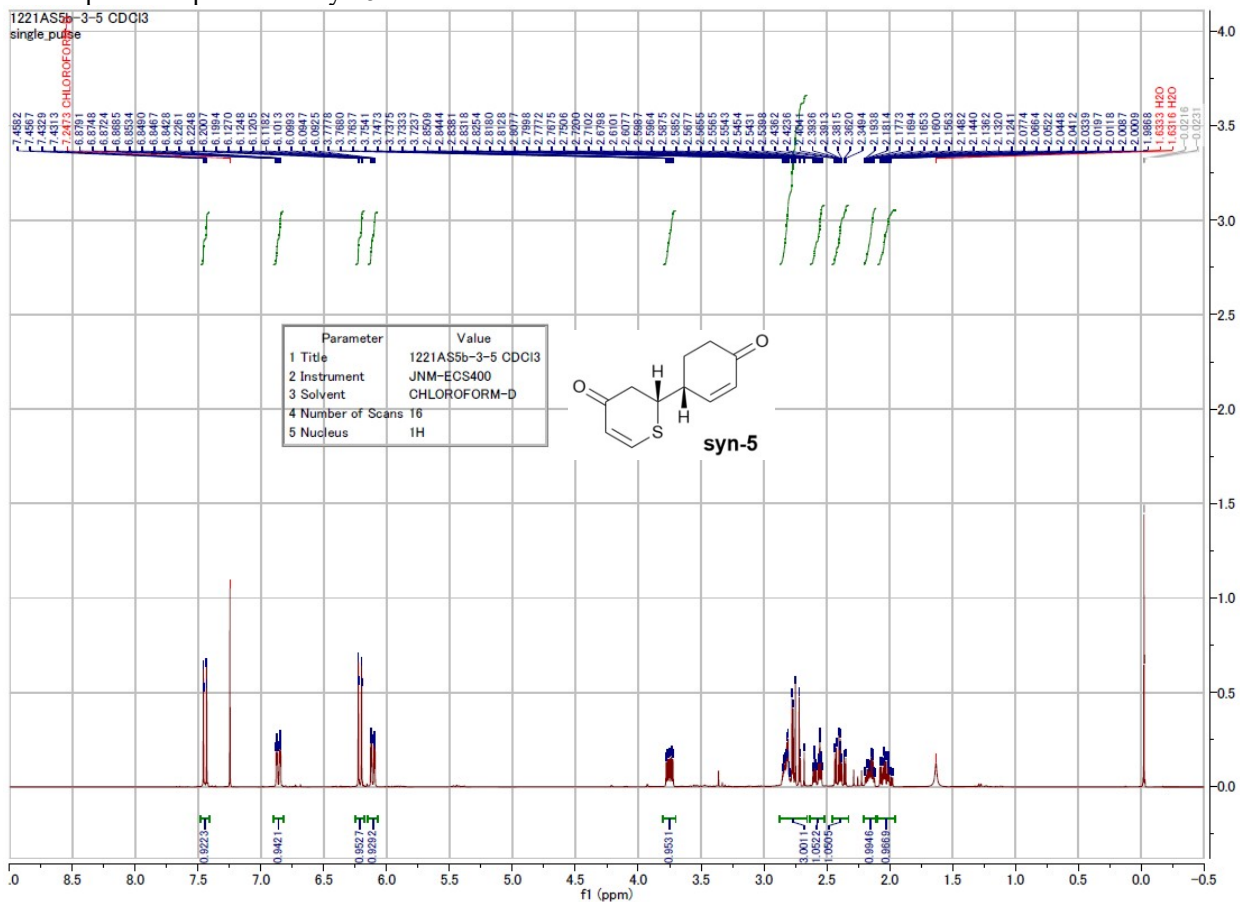


HMBC NMR (600 MHz) spectroscopic data of **anti-5**. Measured in  $\text{CDCl}_3$ .



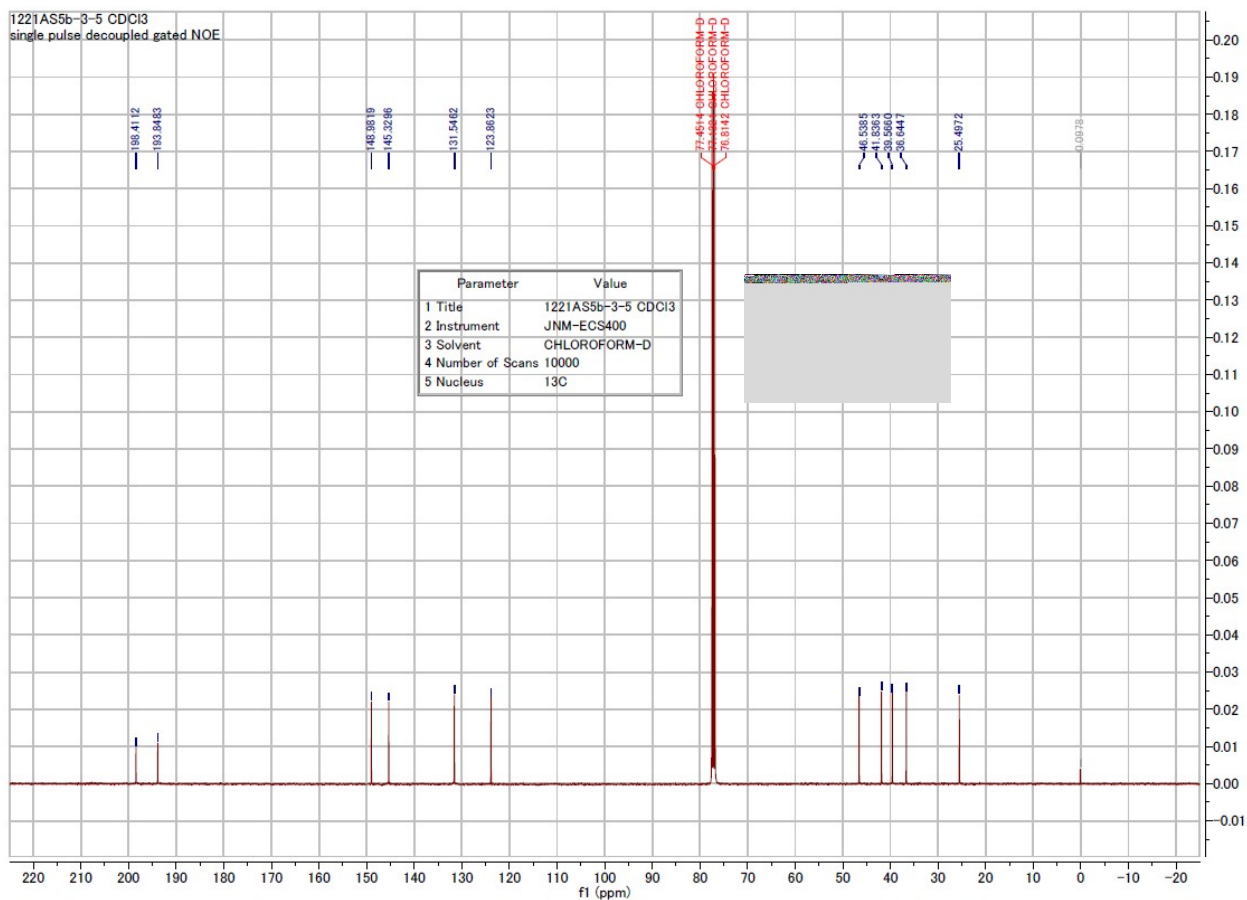
COSY NMR (600 MHz) spectroscopic data of anti-5. Measured in CDCl<sub>3</sub>.

NMR spectroscopic data of syn-5

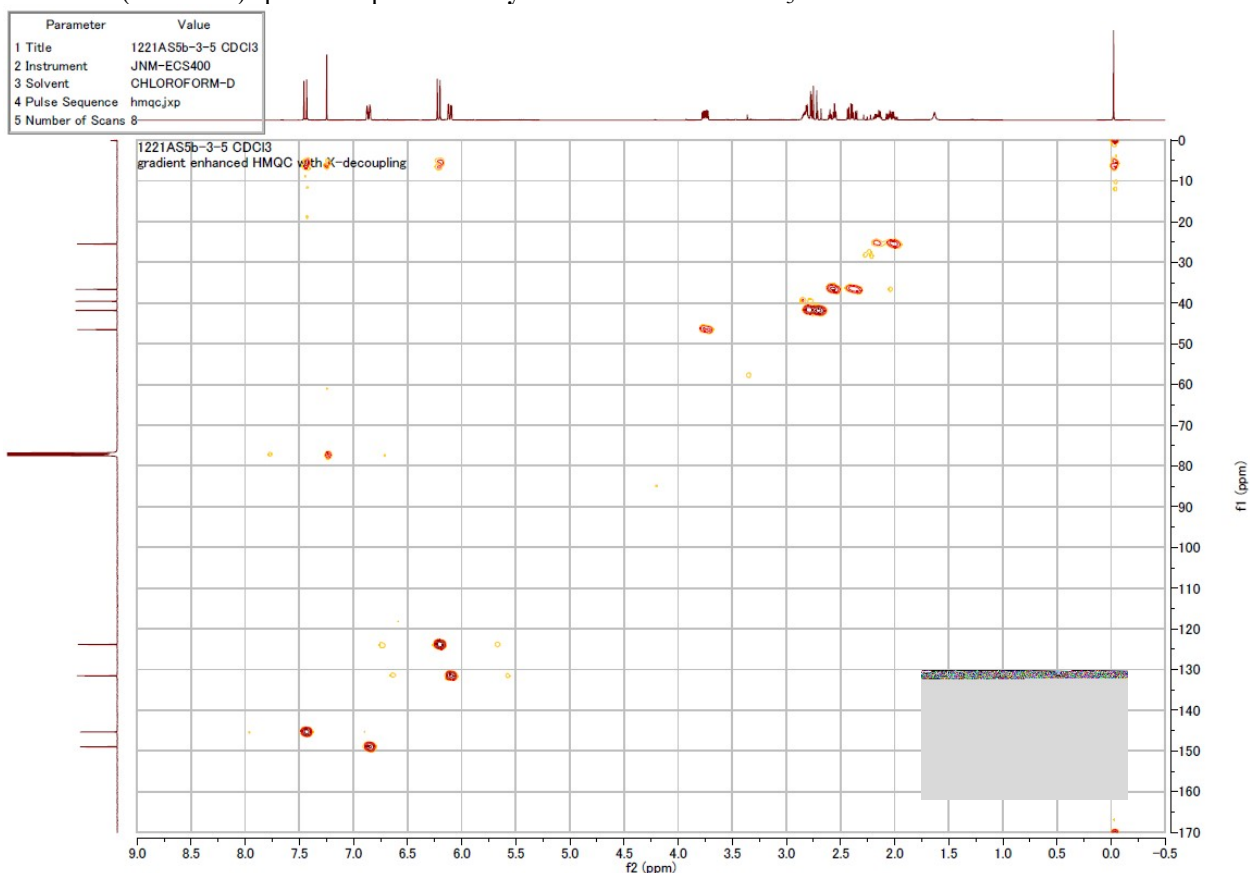


<sup>1</sup>H-NMR (400 MHz) spectroscopic data of syn-5. Measured in CDCl<sub>3</sub>.



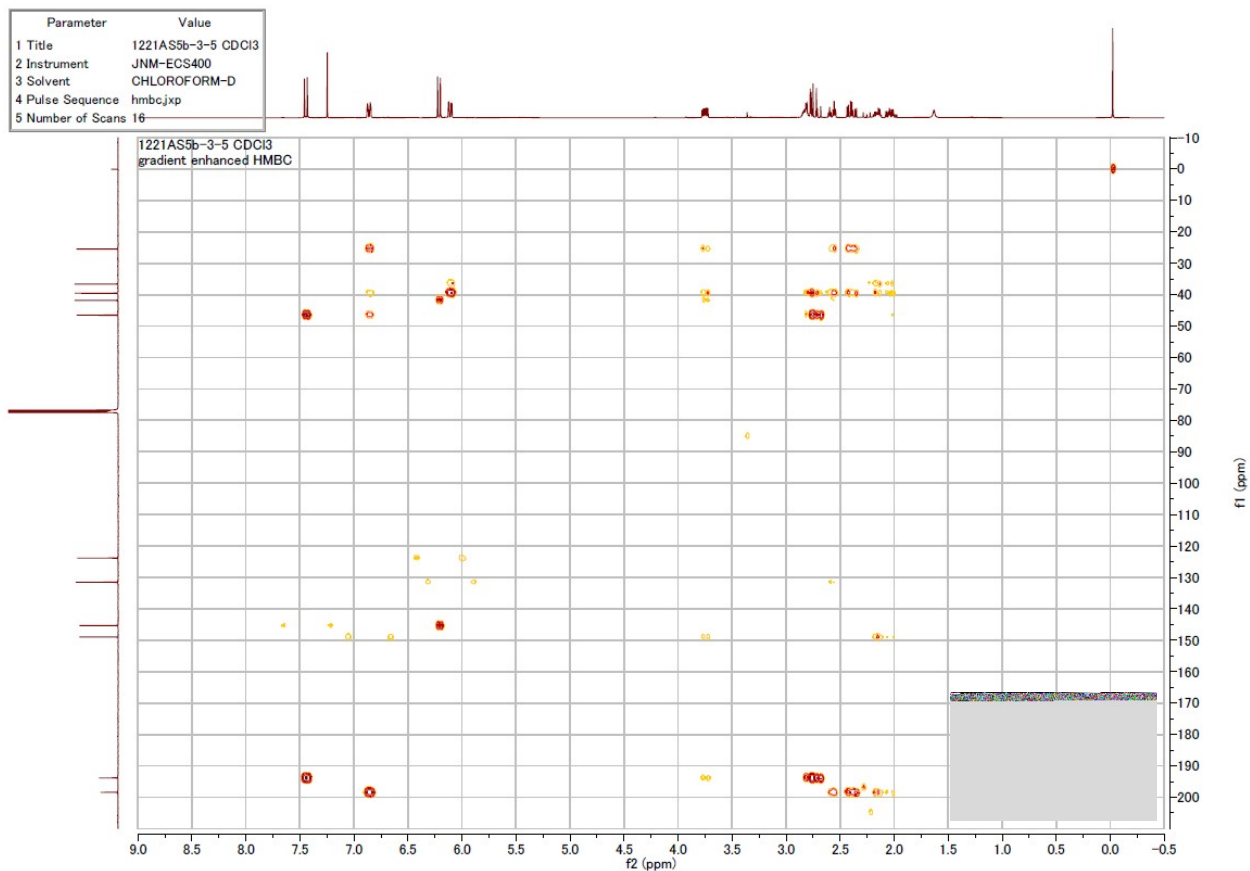


$^{13}\text{C}$ -NMR (100 MHz) spectroscopic data of **syn-5**. Measured in  $\text{CDCl}_3$ .

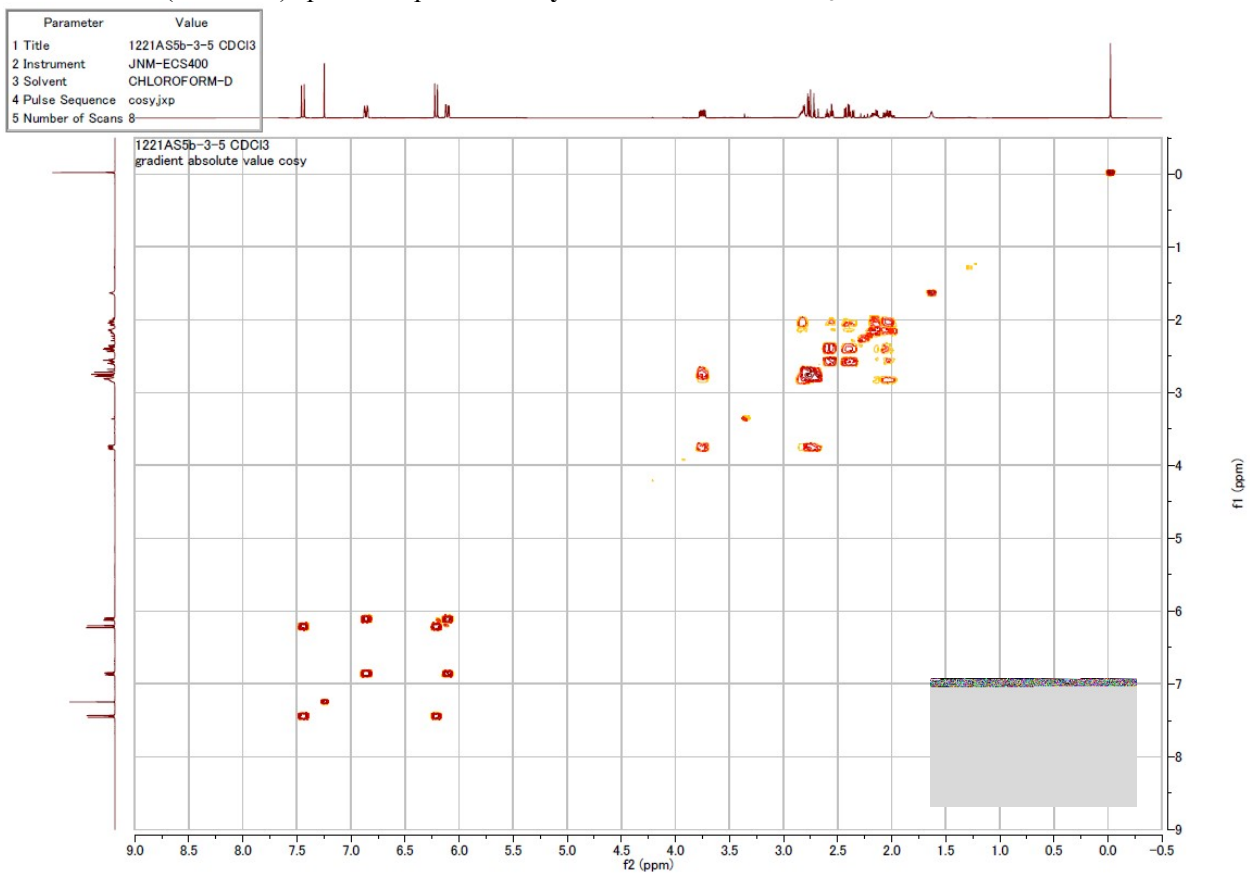


HMQC NMR (400 MHz) spectroscopic data of **syn-5**. Measured in  $\text{CDCl}_3$ .



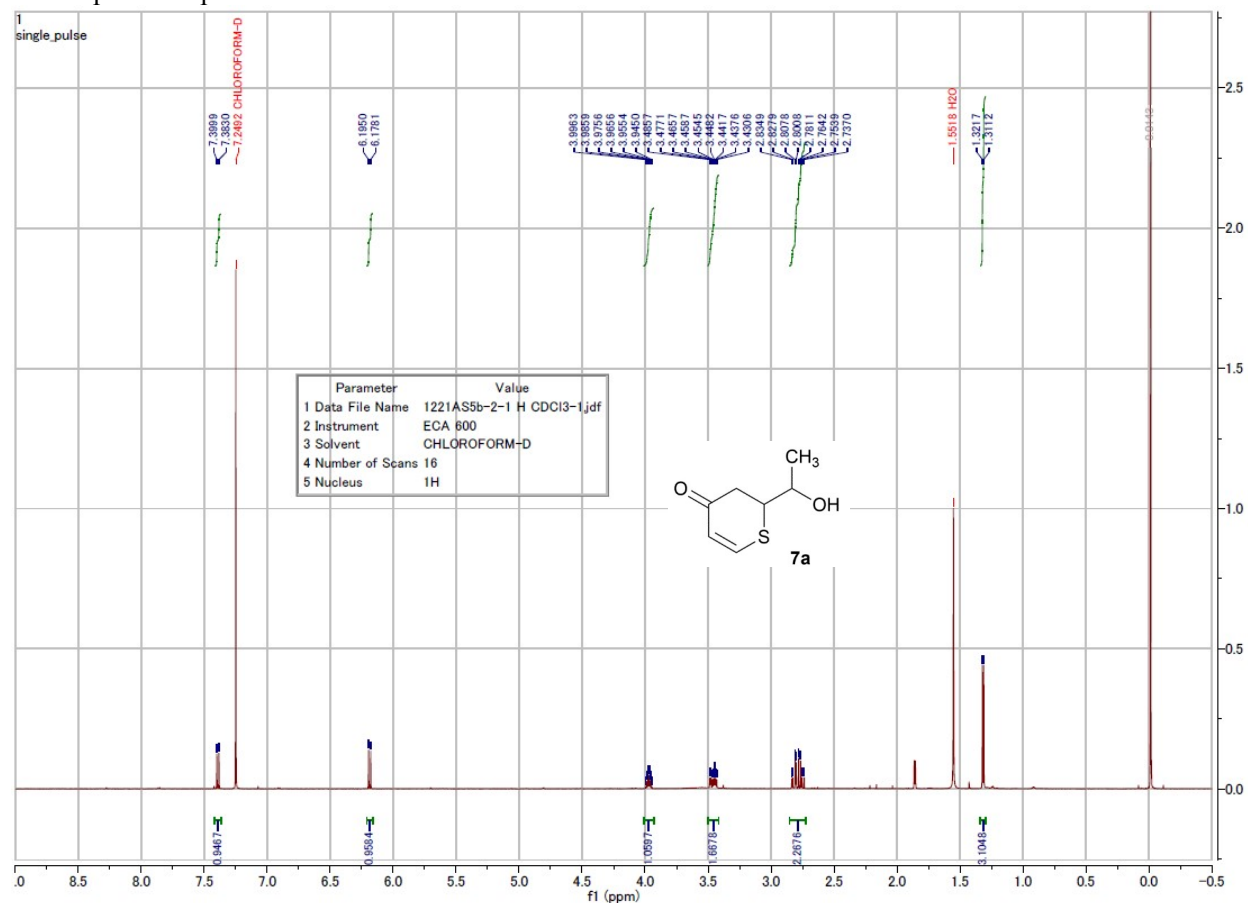


HMBC NMR (400 MHz) spectroscopic data of **syn-5**. Measured in CDCl<sub>3</sub>.

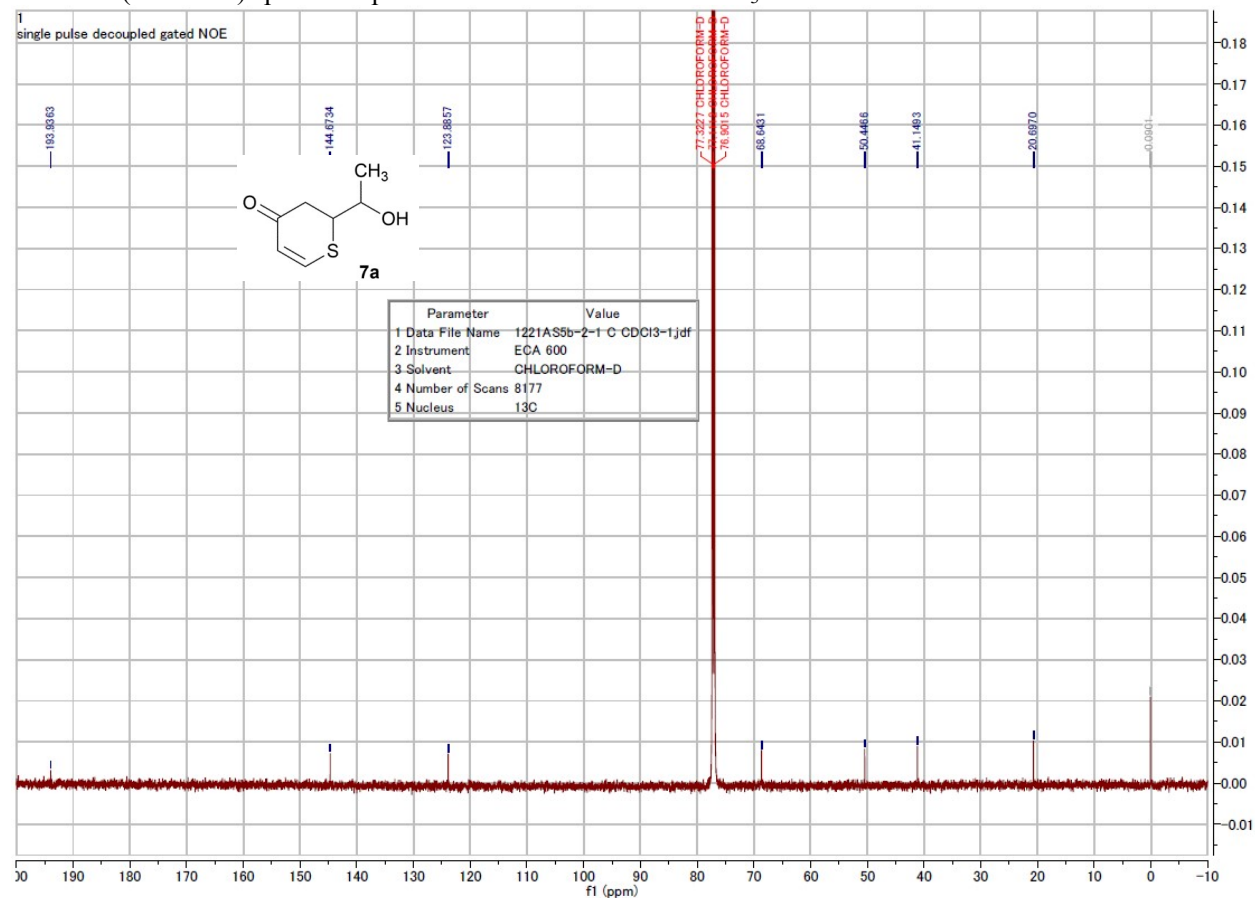


COSY NMR (400 MHz) spectroscopic data of **syn-5**. Measured in CDCl<sub>3</sub>.

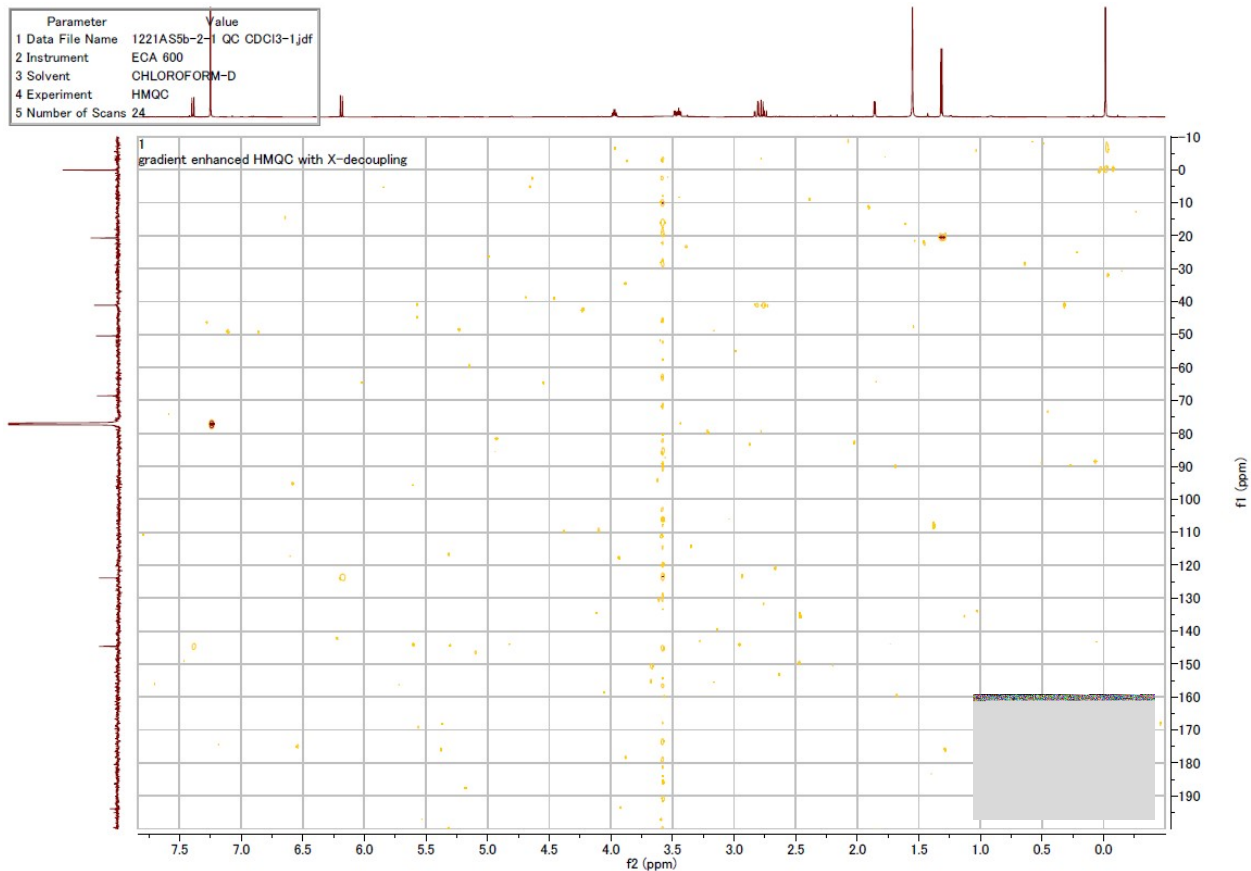
# NMR spectroscopic data of 7a



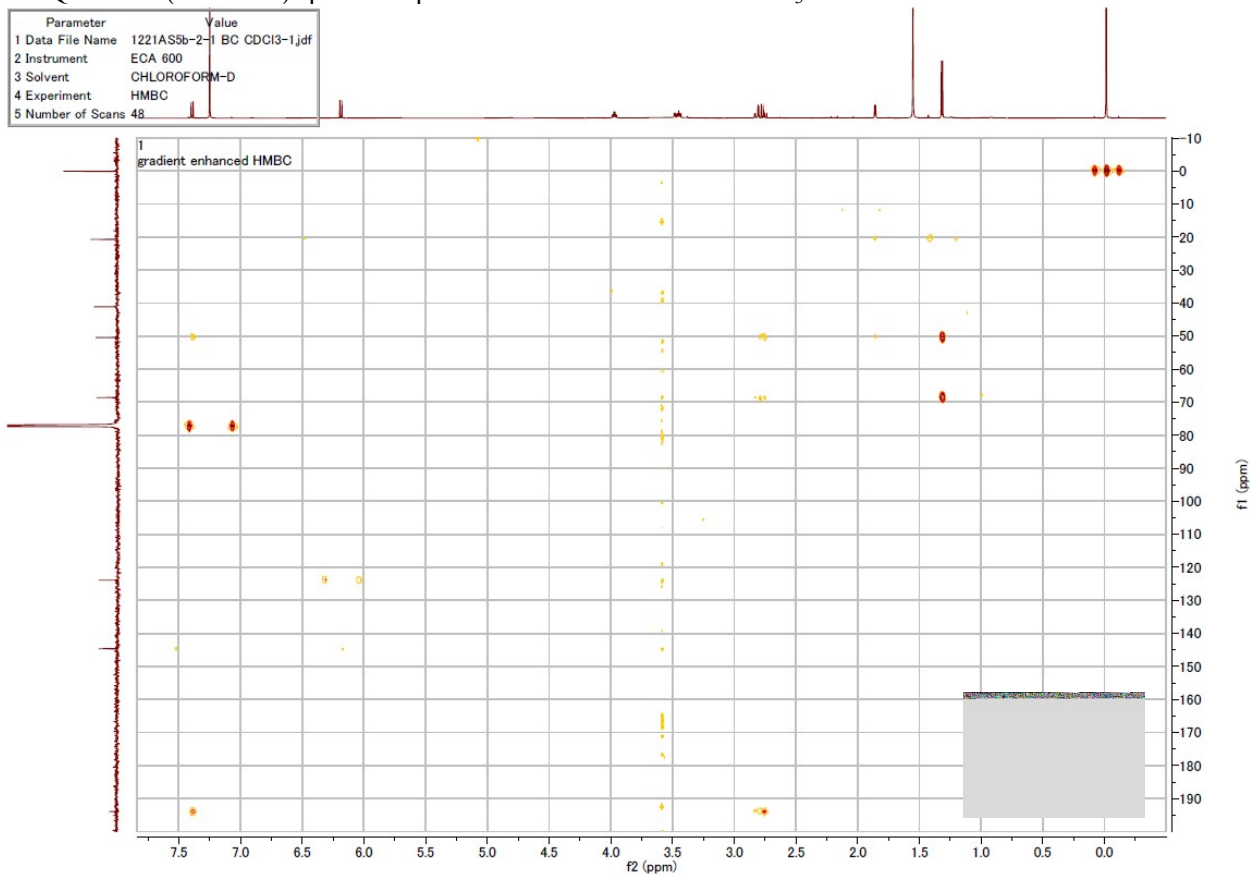
<sup>1</sup>H-NMR (600 MHz) spectroscopic data of 7a. Measured in CDCl<sub>3</sub>.



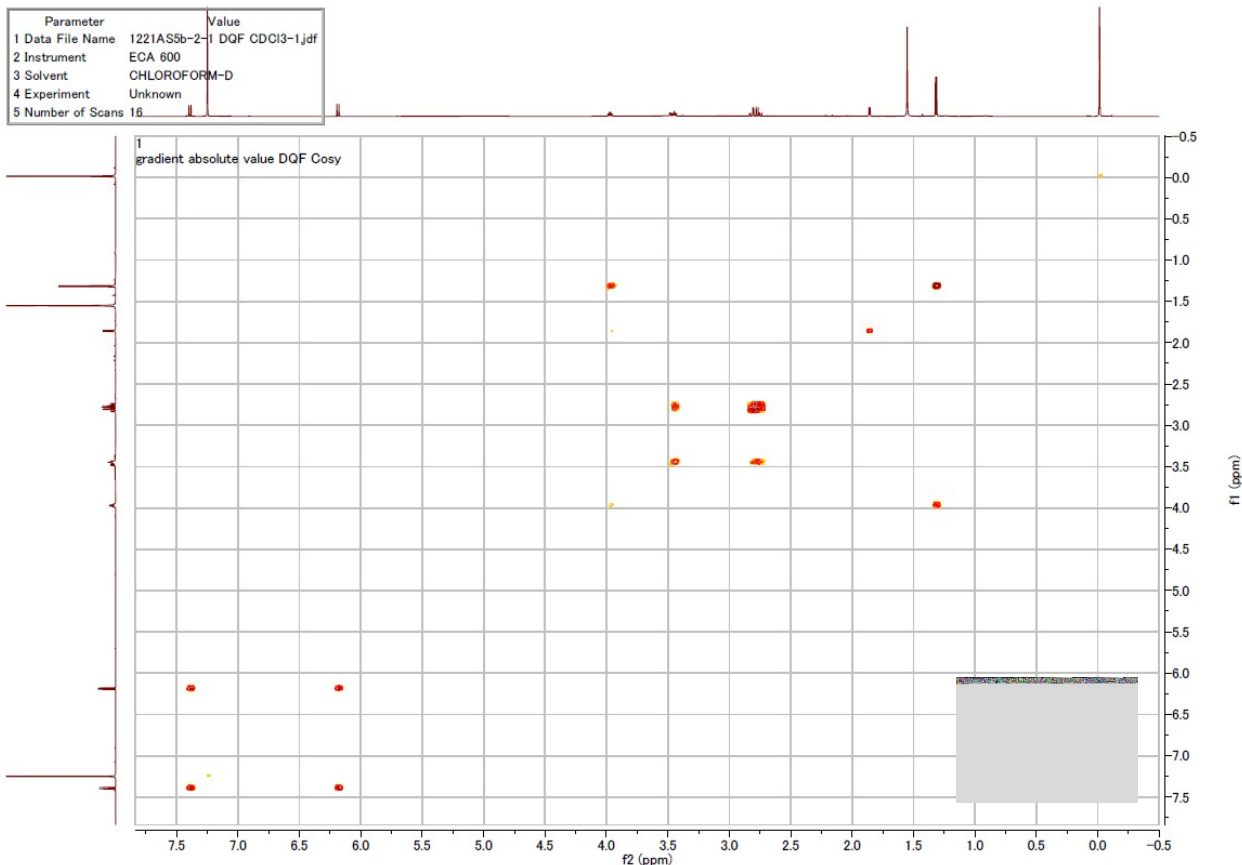
<sup>13</sup>C-NMR (150 MHz) spectroscopic data of 7a. Measured in CDCl<sub>3</sub>.



HMQC NMR (600 MHz) spectroscopic data of **7a**. Measured in  $\text{CDCl}_3$ .

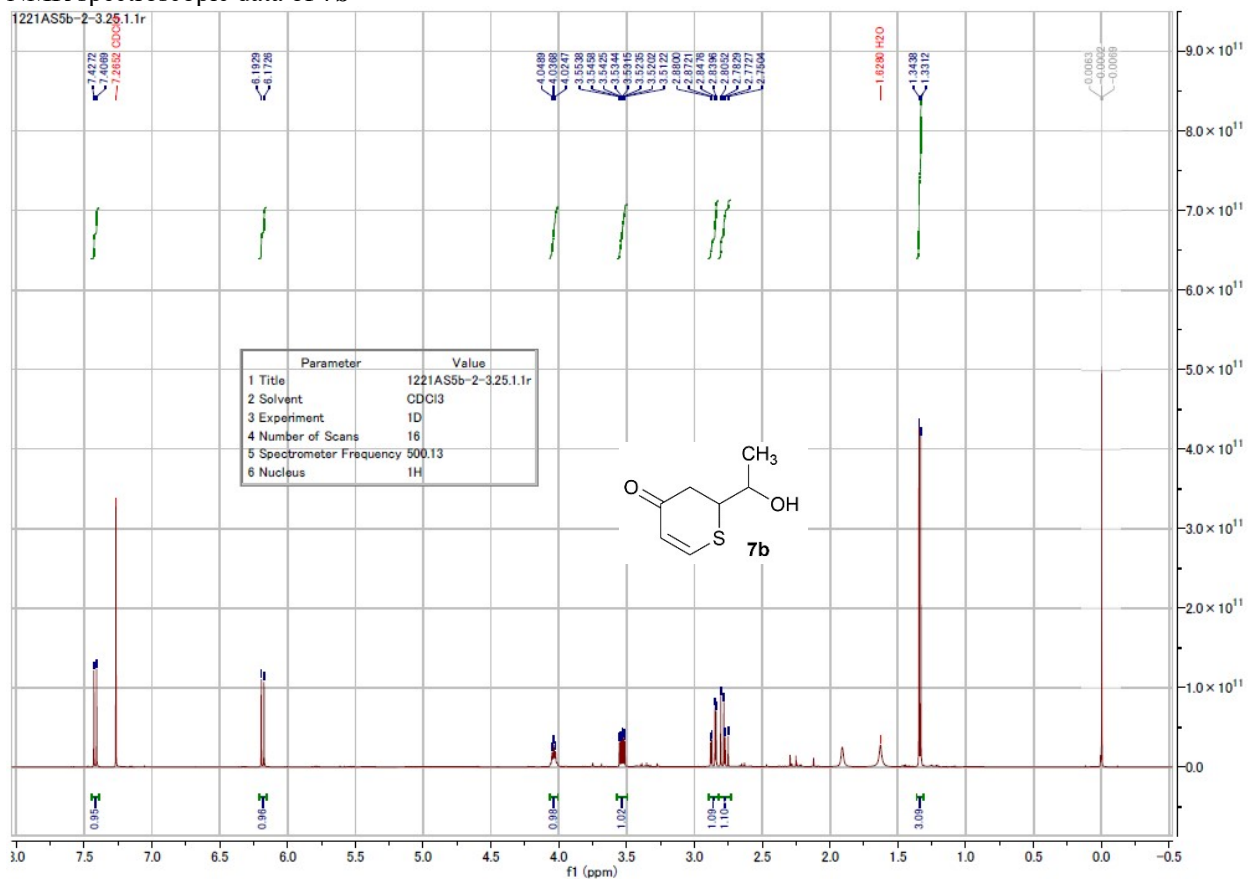


HMBC NMR (600 MHz) spectroscopic data of **7a**. Measured in  $\text{CDCl}_3$ .

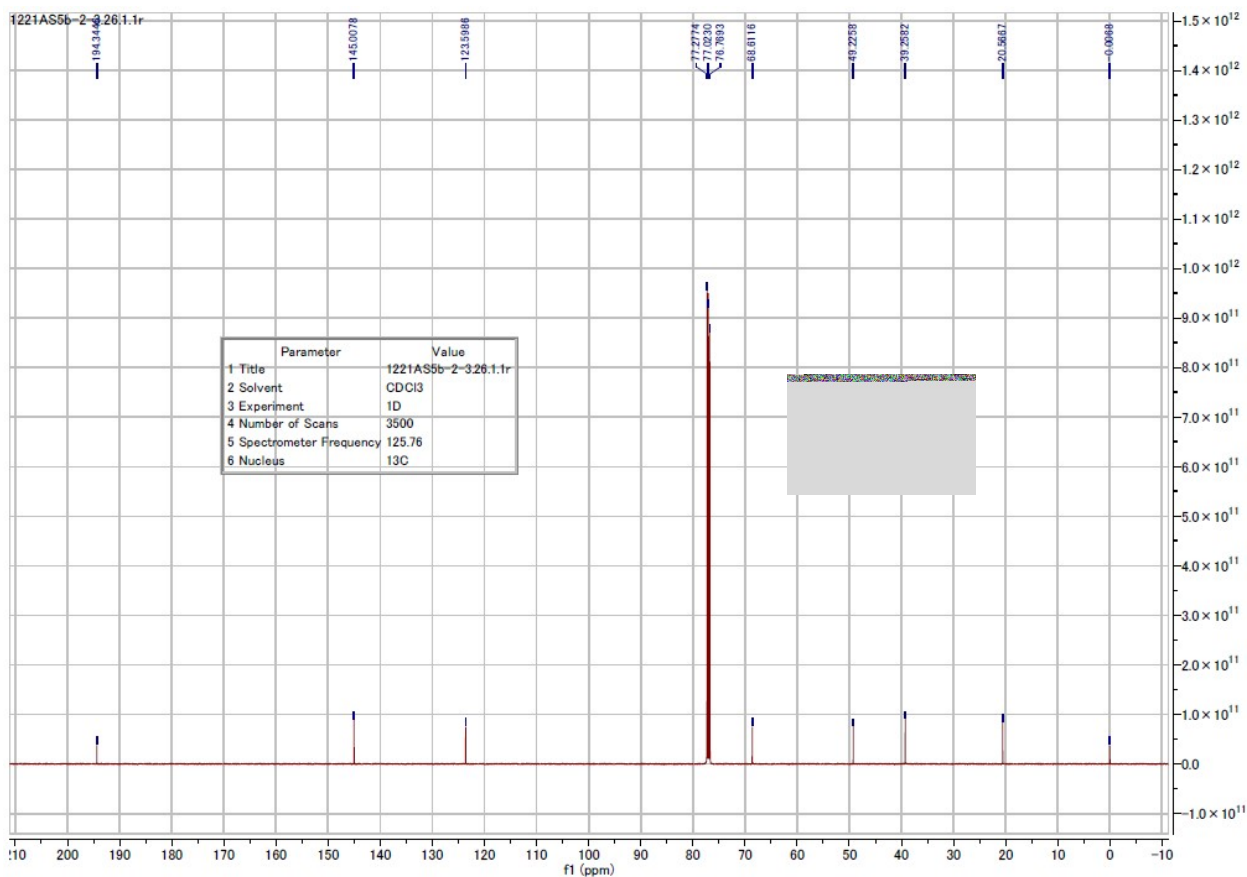


COSY NMR (600 MHz) spectroscopic data of **7a**. Measured in  $\text{CDCl}_3$ .

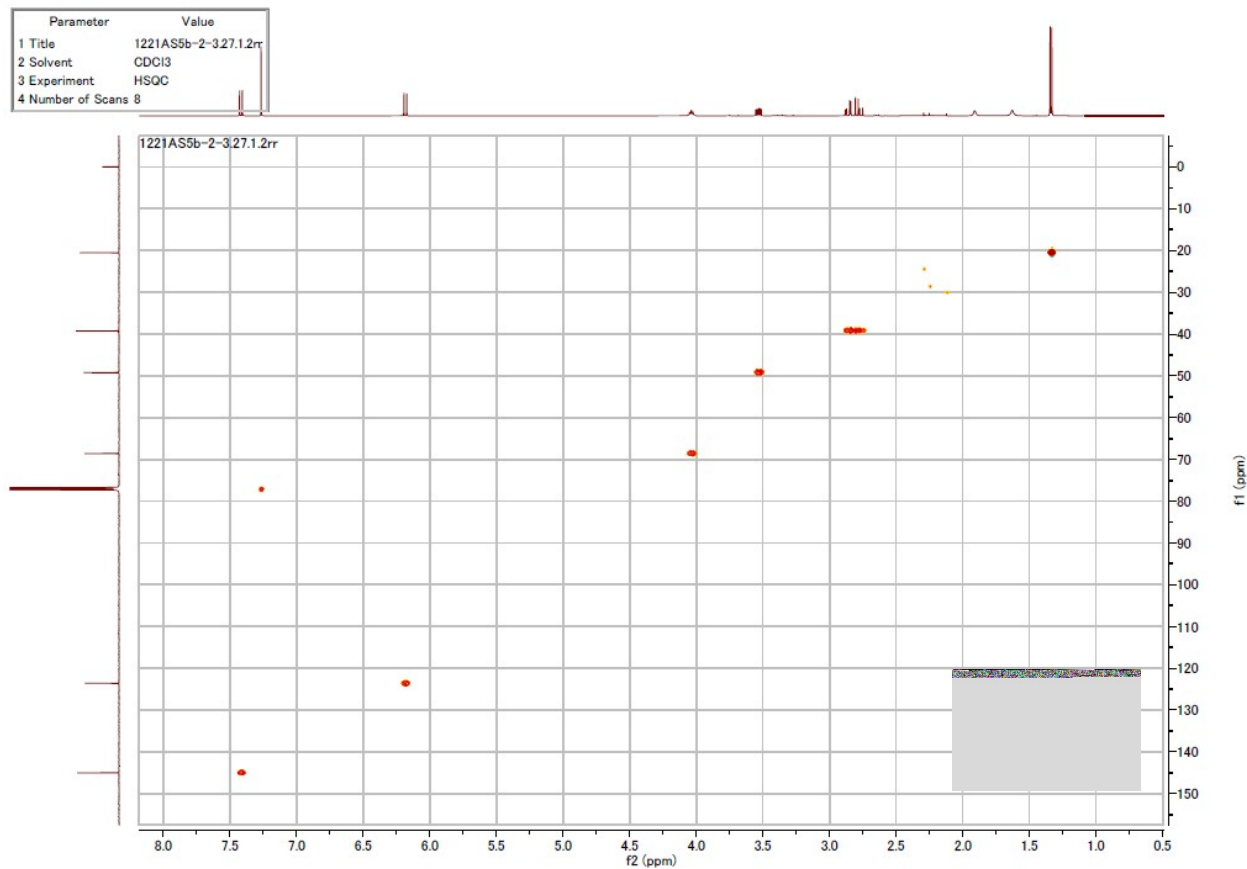
NMR spectroscopic data of **7b**



$^1\text{H}$ -NMR (500 MHz) spectroscopic data of **7b**. Measured in  $\text{CDCl}_3$ .

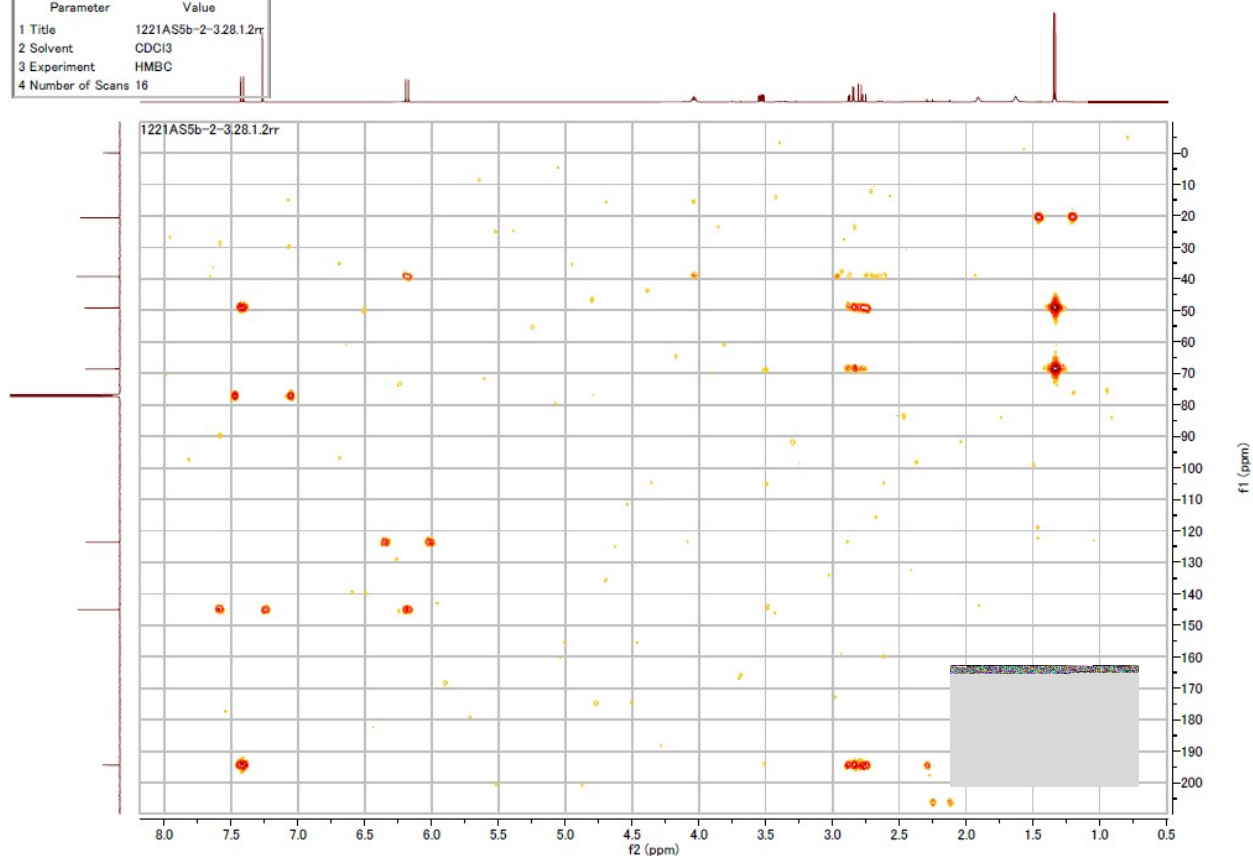


$^{13}\text{C}$ -NMR (125 MHz) spectroscopic data of **7b**. Measured in  $\text{CDCl}_3$ .



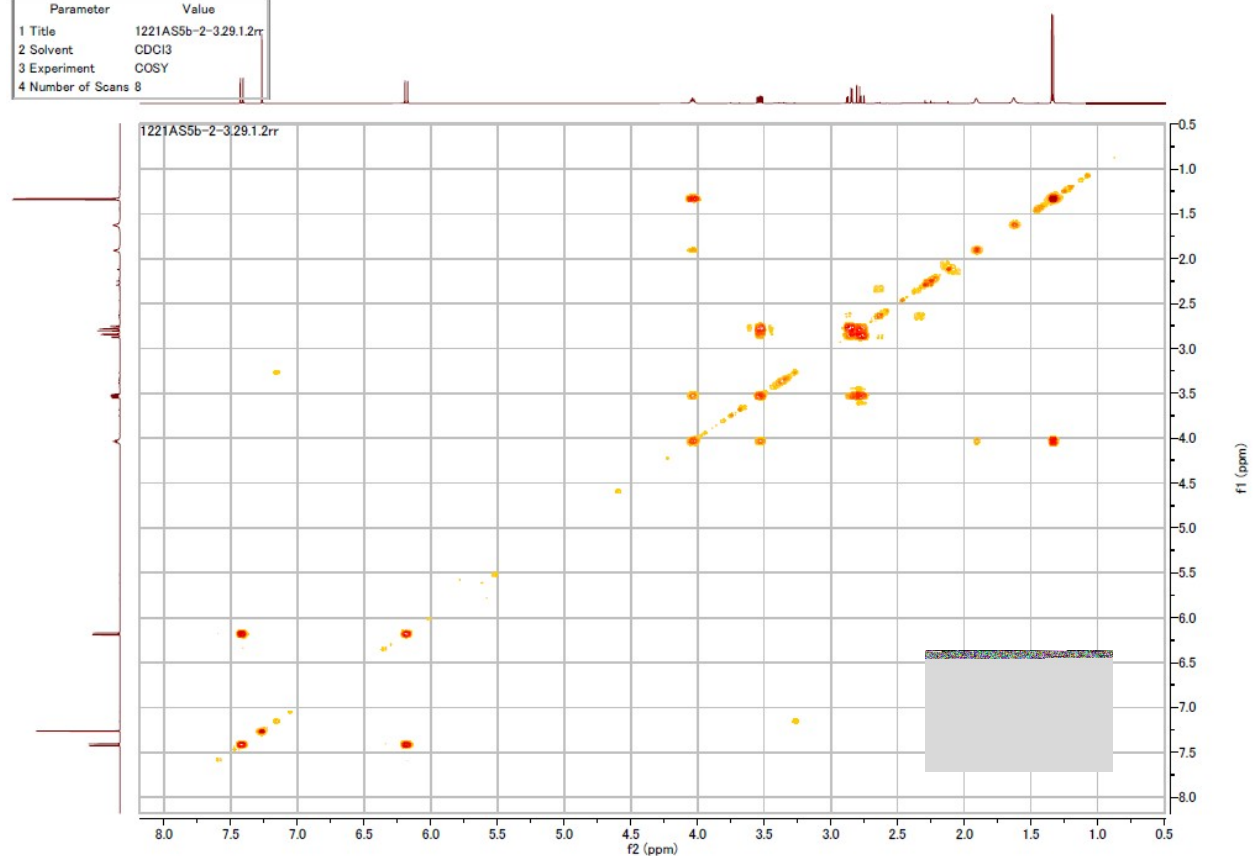
HMOC NMR (500 MHz) spectroscopic data of **7b**. Measured in  $\text{CDCl}_3$ .

Parameter	Value
1 Title	1221AS5b-2-3.28.1.2rr
2 Solvent	CDCl3
3 Experiment	HMBC
4 Number of Scans	16



HMBC NMR (500 MHz) spectroscopic data of **7b**. Measured in CDCl<sub>3</sub>.

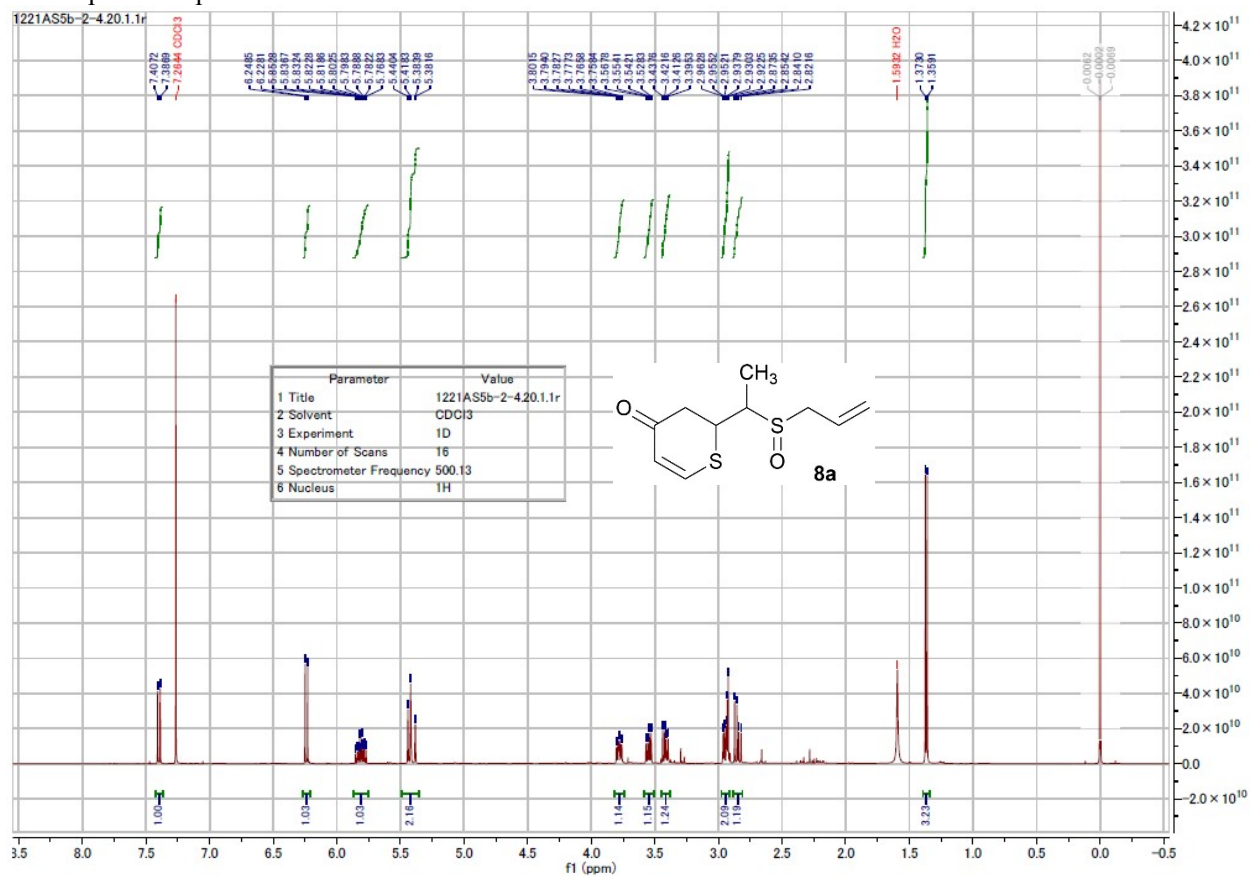
Parameter	Value
1 Title	1221AS5b-2-3.29.1.2rr
2 Solvent	CDCl3
3 Experiment	COSY
4 Number of Scans	8



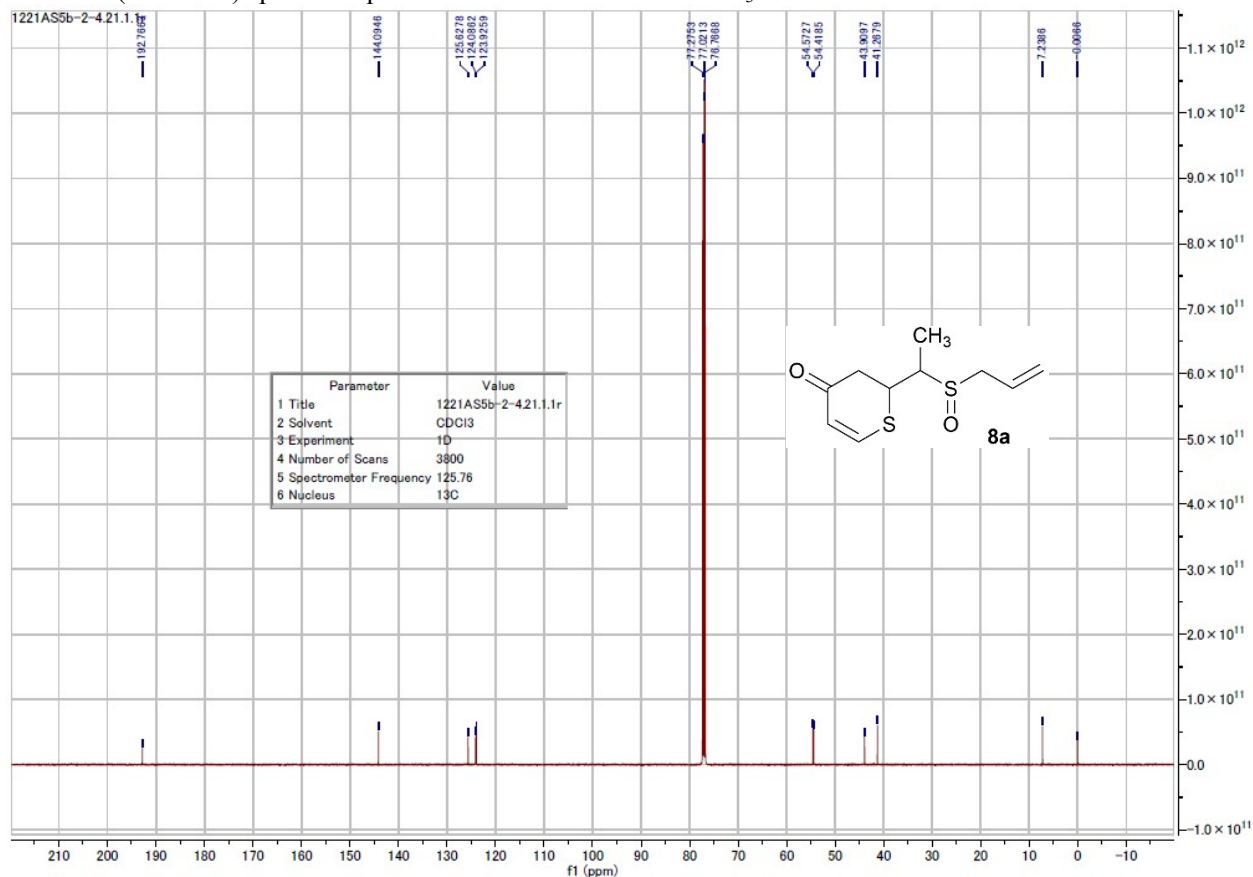
COSY NMR (500 MHz) spectroscopic data of **7b**. Measured in CDCl<sub>3</sub>.



# NMR spectroscopic data of **8a**

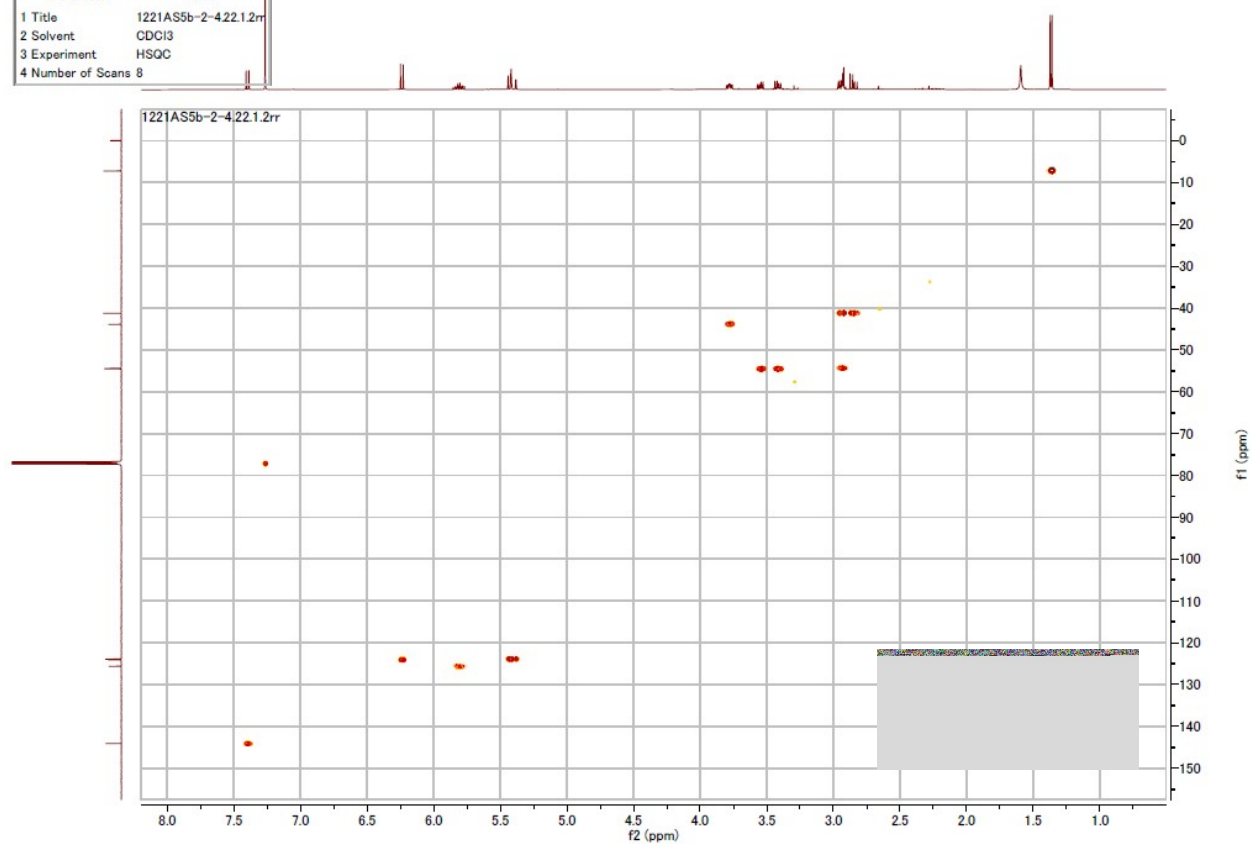


## <sup>1</sup>H-NMR (500 MHz) spectroscopic data of **8a**. Measured in CDCl<sub>3</sub>.



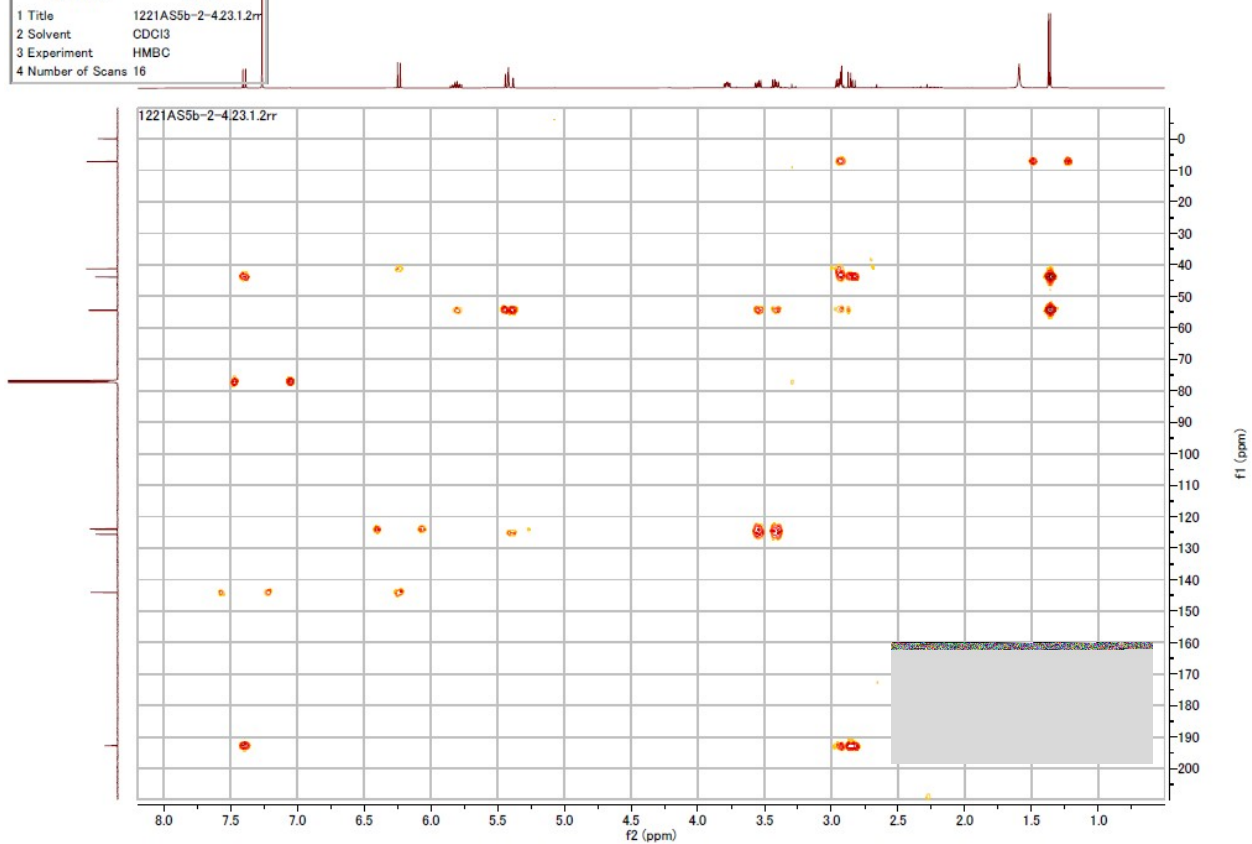
## <sup>13</sup>C-NMR (125 MHz) spectroscopic data of **8a**. Measured in CDCl<sub>3</sub>.

Parameter	Value
1 Title	1221AS5b-2-4.22.1.2r
2 Solvent	CDCl3
3 Experiment	HSQC
4 Number of Scans	8



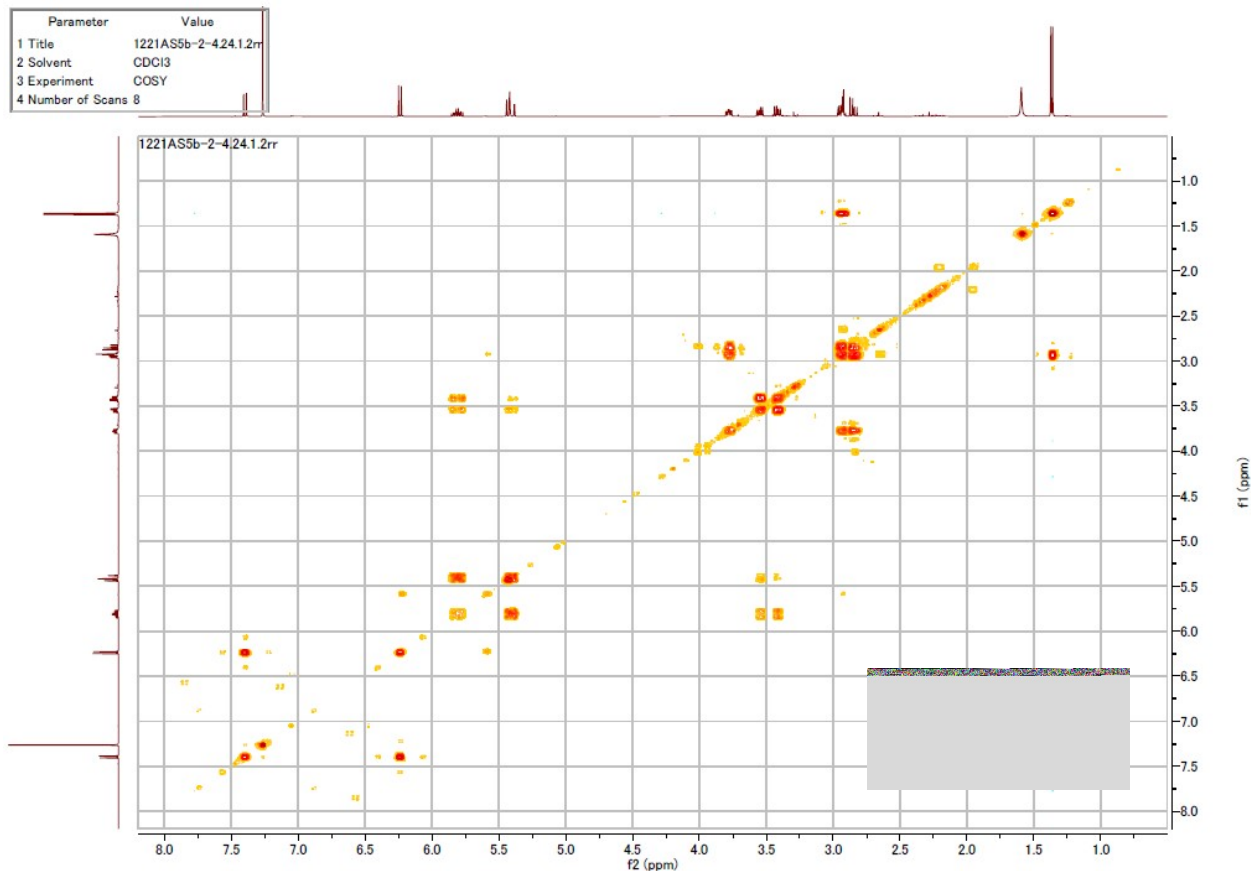
HMQC NMR (500 MHz) spectroscopic data of **8a**. Measured in CDCl<sub>3</sub>.

Parameter	Value
1 Title	1221AS5b-2-4.23.1.2r
2 Solvent	CDCl3
3 Experiment	HMBC
4 Number of Scans	16



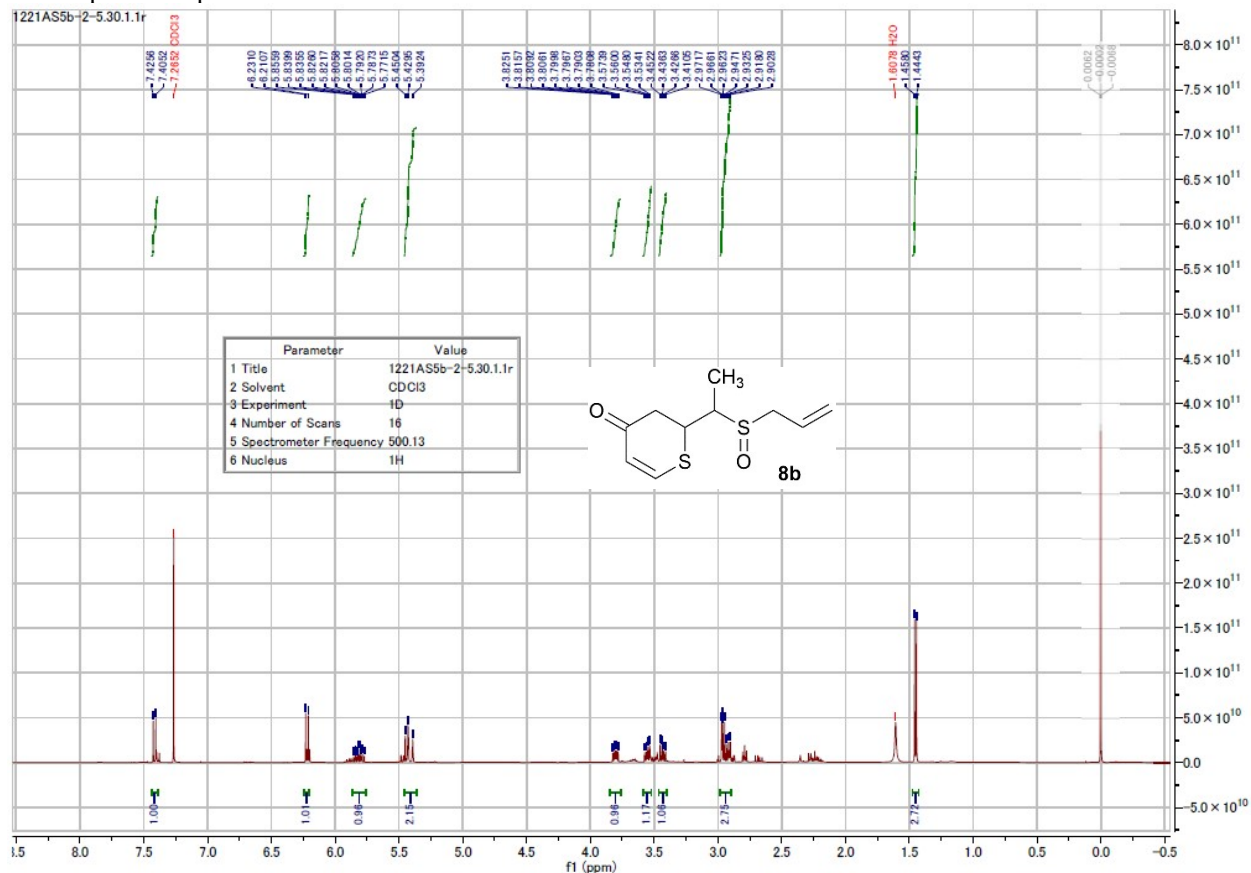
HMBC NMR (500 MHz) spectroscopic data of **8a**. Measured in CDCl<sub>3</sub>.



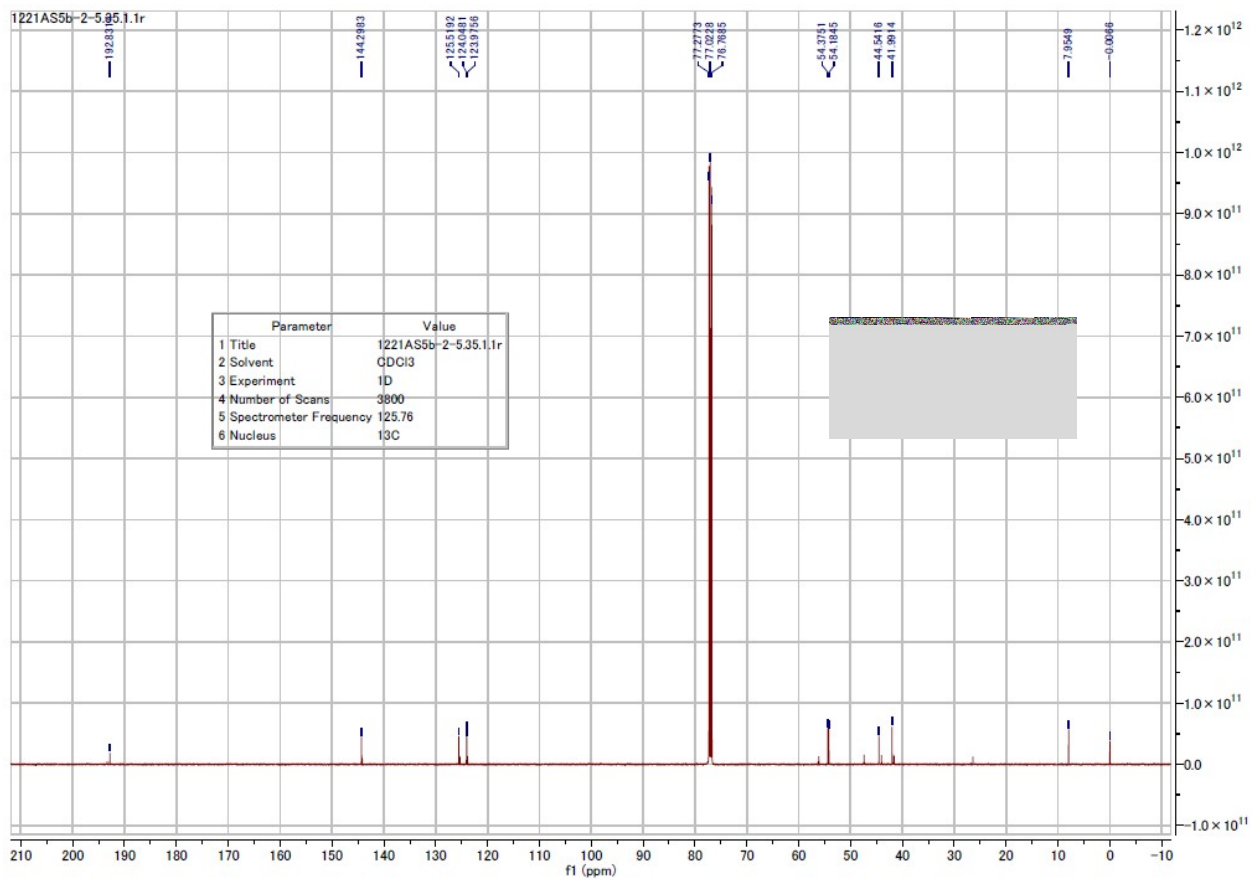


COSY NMR (500 MHz) spectroscopic data of **8a**. Measured in CDCl<sub>3</sub>.

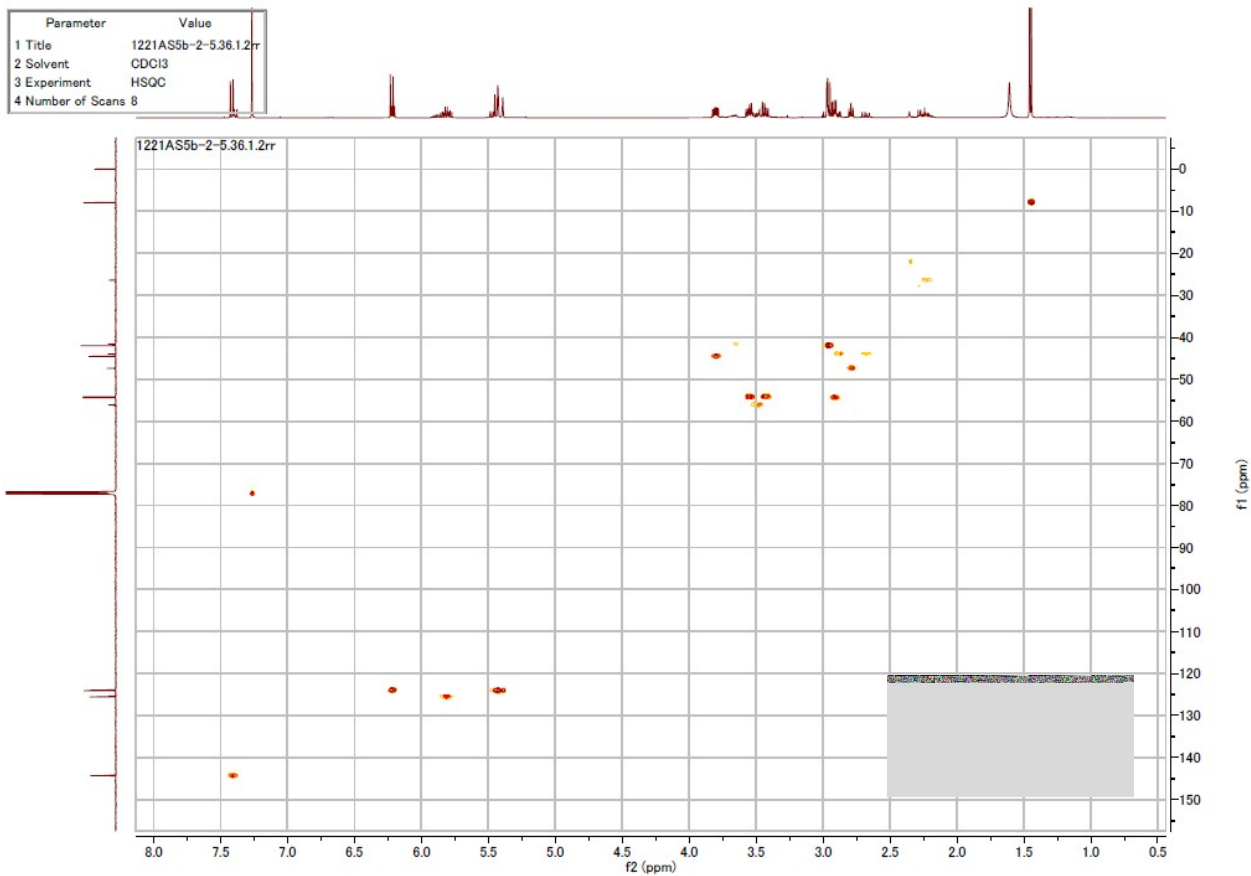
NMR spectroscopic data of **8b**



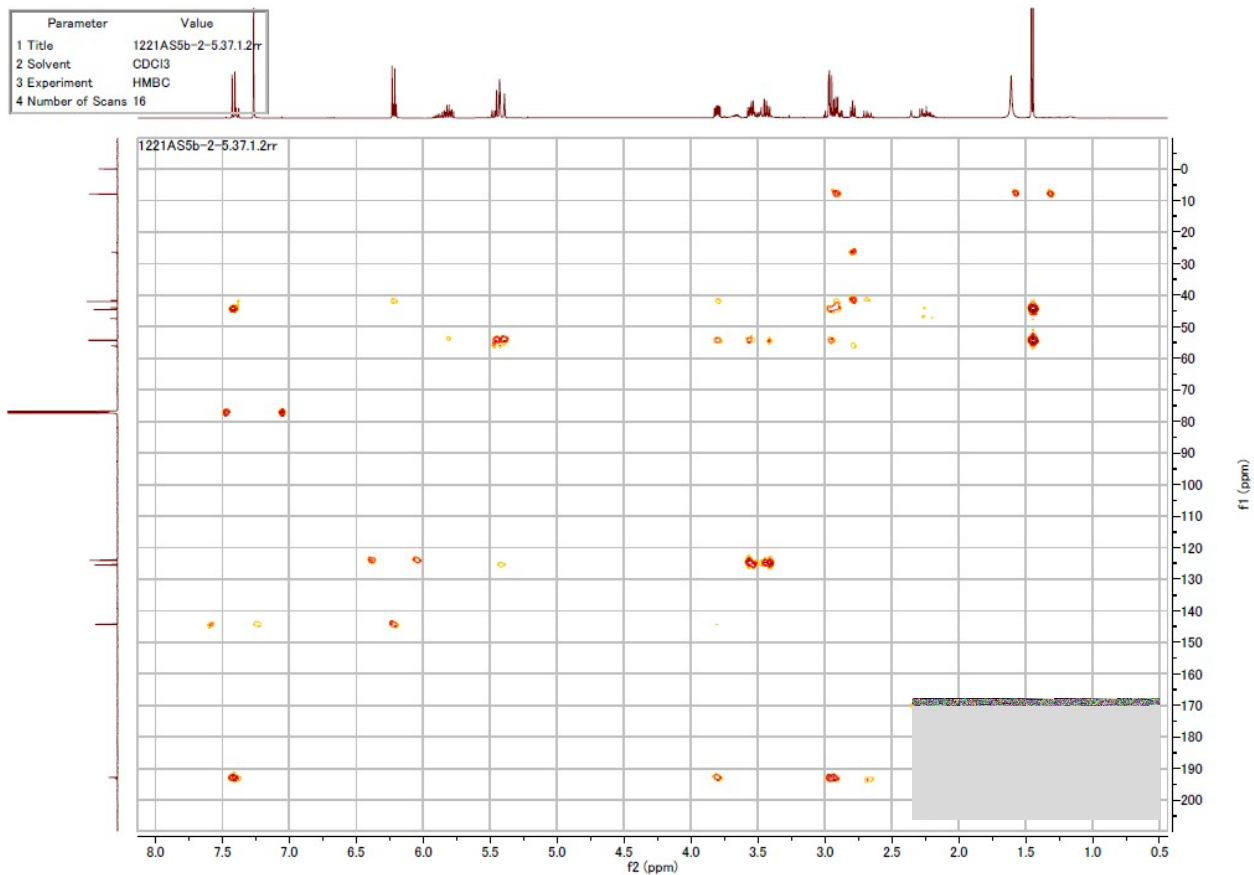
<sup>1</sup>H-NMR (500 MHz) spectroscopic data of **8b**. Measured in CDCl<sub>3</sub>.



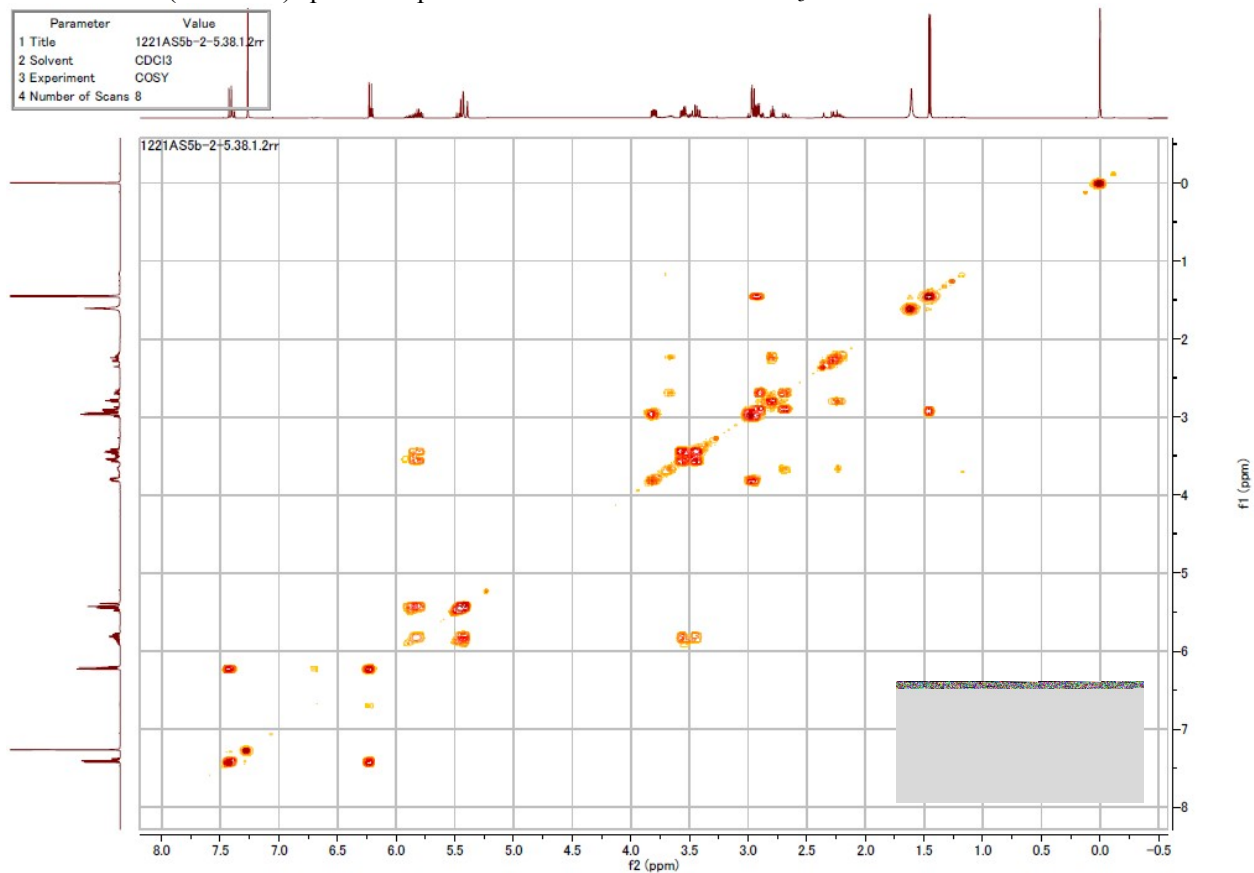
$^{13}\text{C}$ -NMR (125 MHz) spectroscopic data of **8b**. Measured in  $\text{CDCl}_3$ .



HMQC NMR (500 MHz) spectroscopic data of **8b**. Measured in  $\text{CDCl}_3$ .

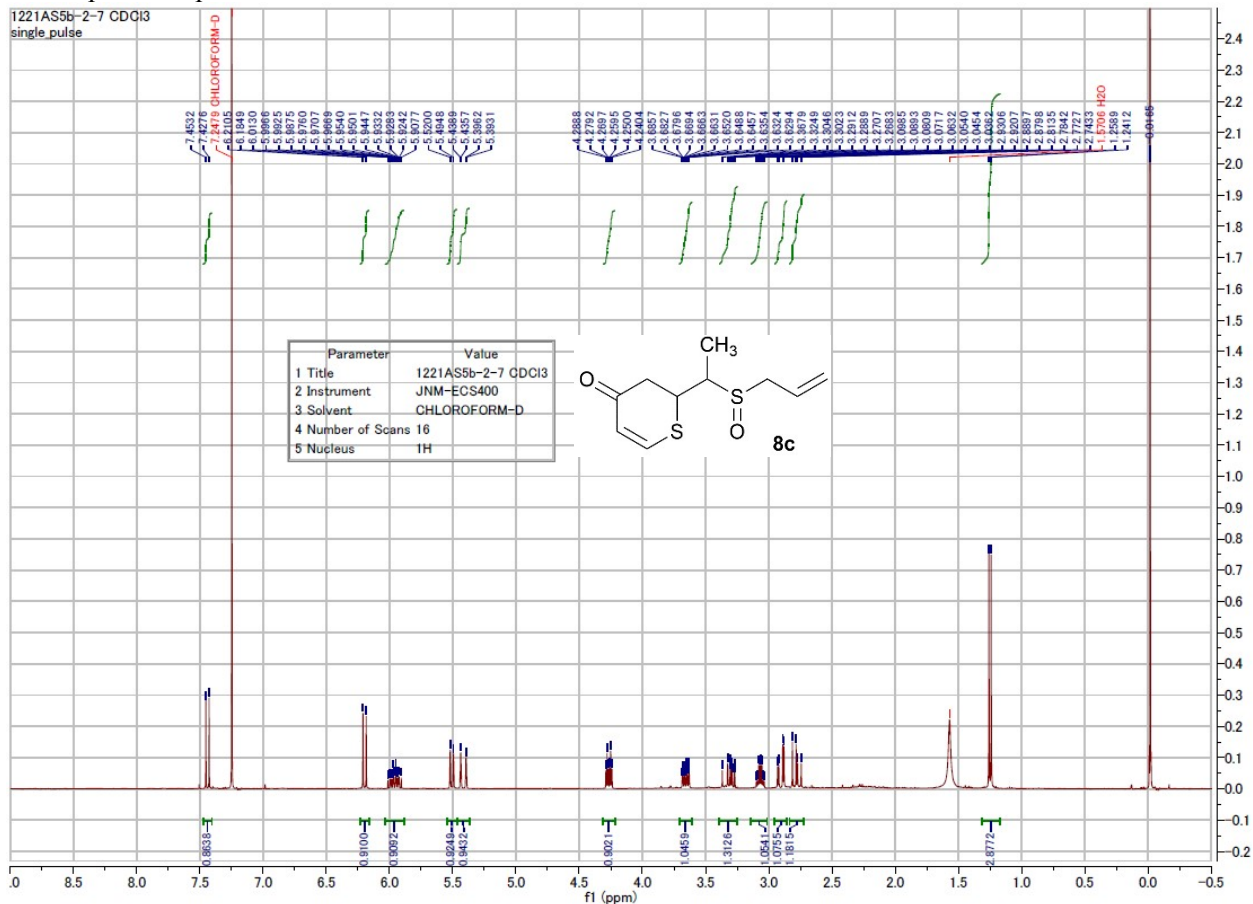


HMBC NMR (500 MHz) spectroscopic data of **8b**. Measured in CDCl<sub>3</sub>.

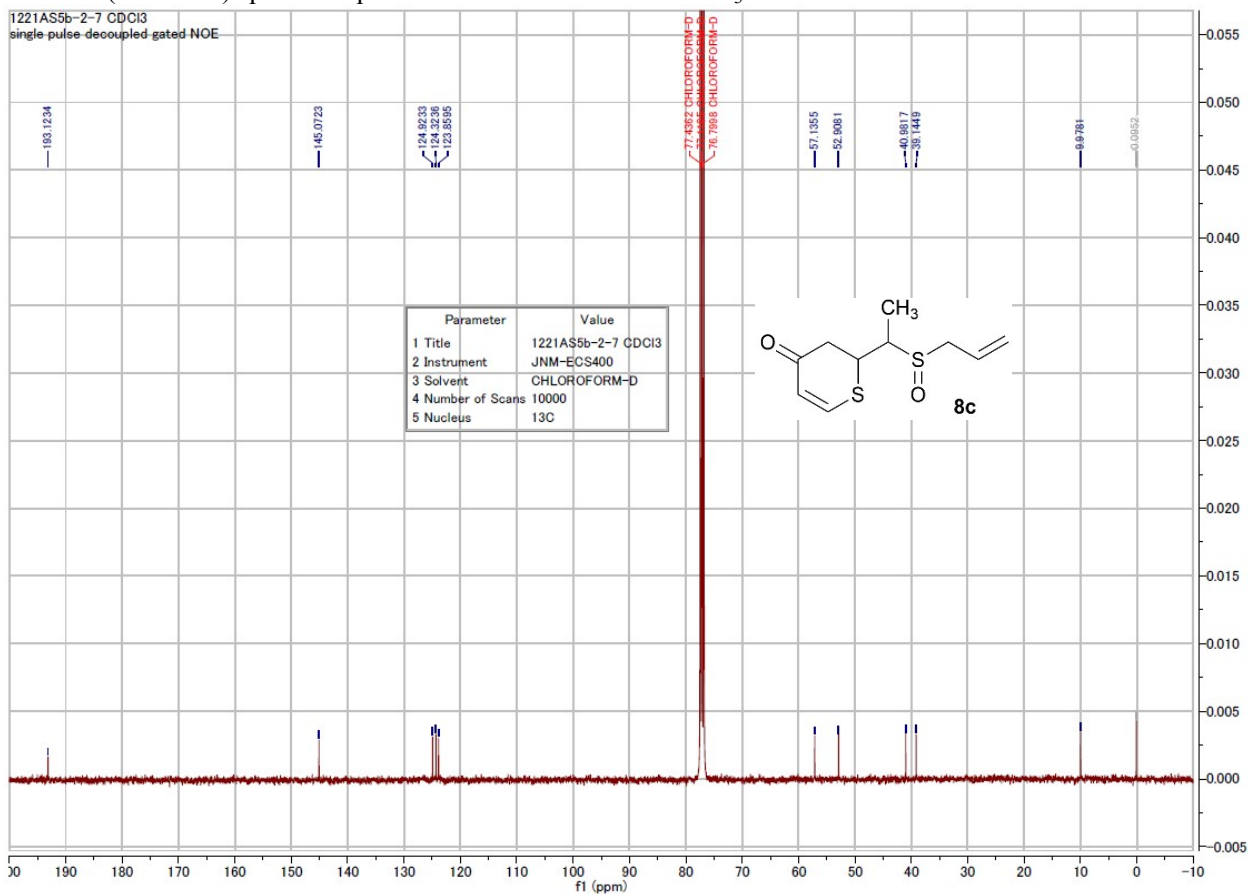


COSY NMR (500 MHz) spectroscopic data of **8b**. Measured in CDCl<sub>3</sub>.

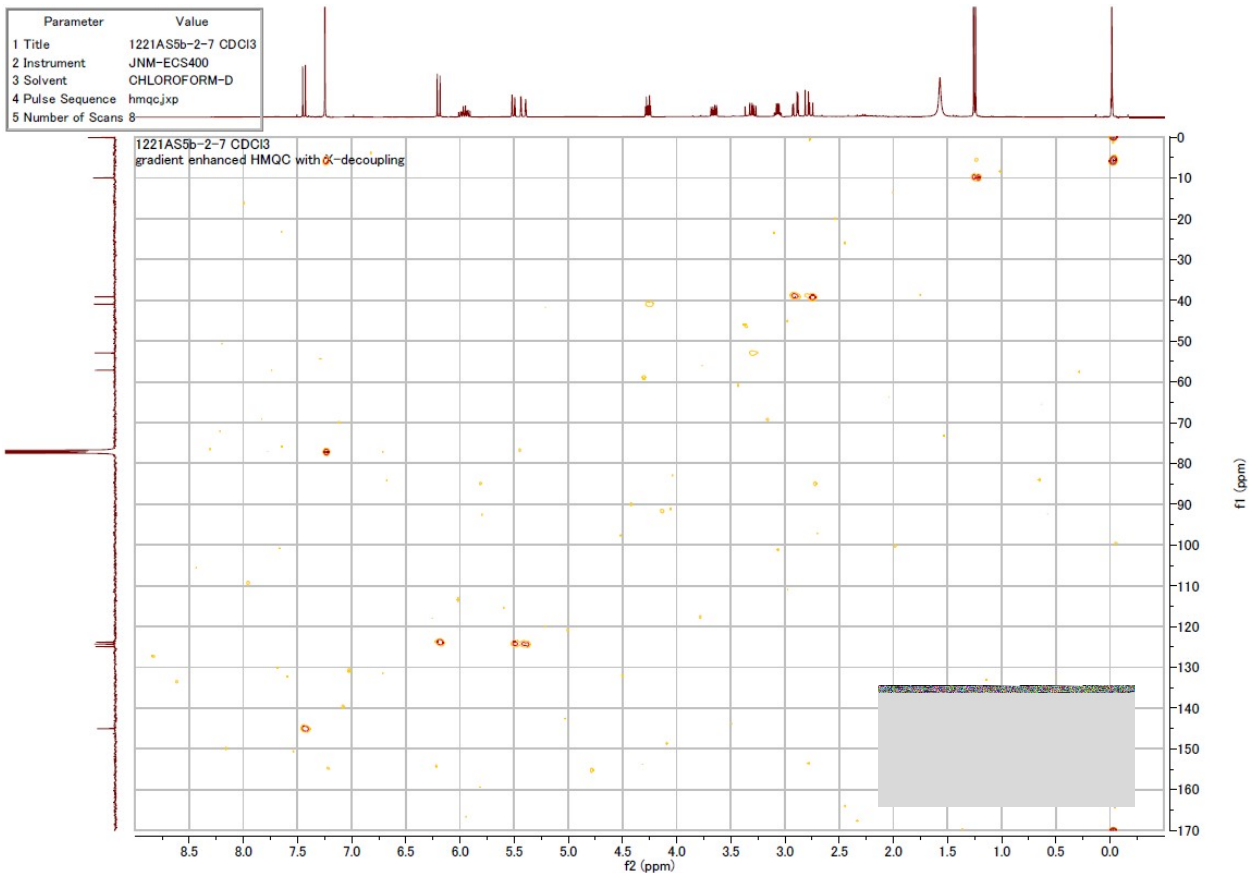
# <sup>1</sup>H-NMR spectroscopic data of **8c**



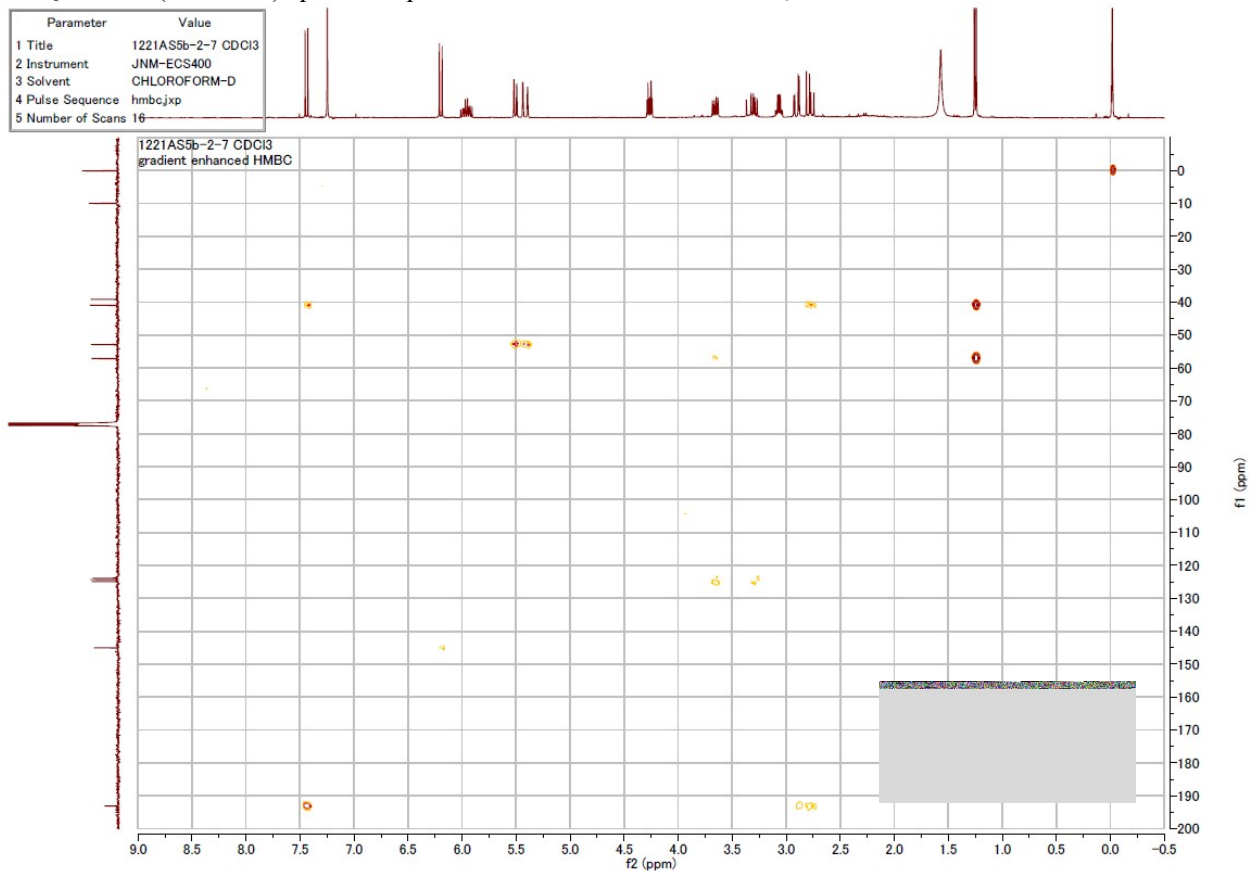
<sup>1</sup>H-NMR (400 MHz) spectroscopic data of **8c**. Measured in CDCl<sub>3</sub>.



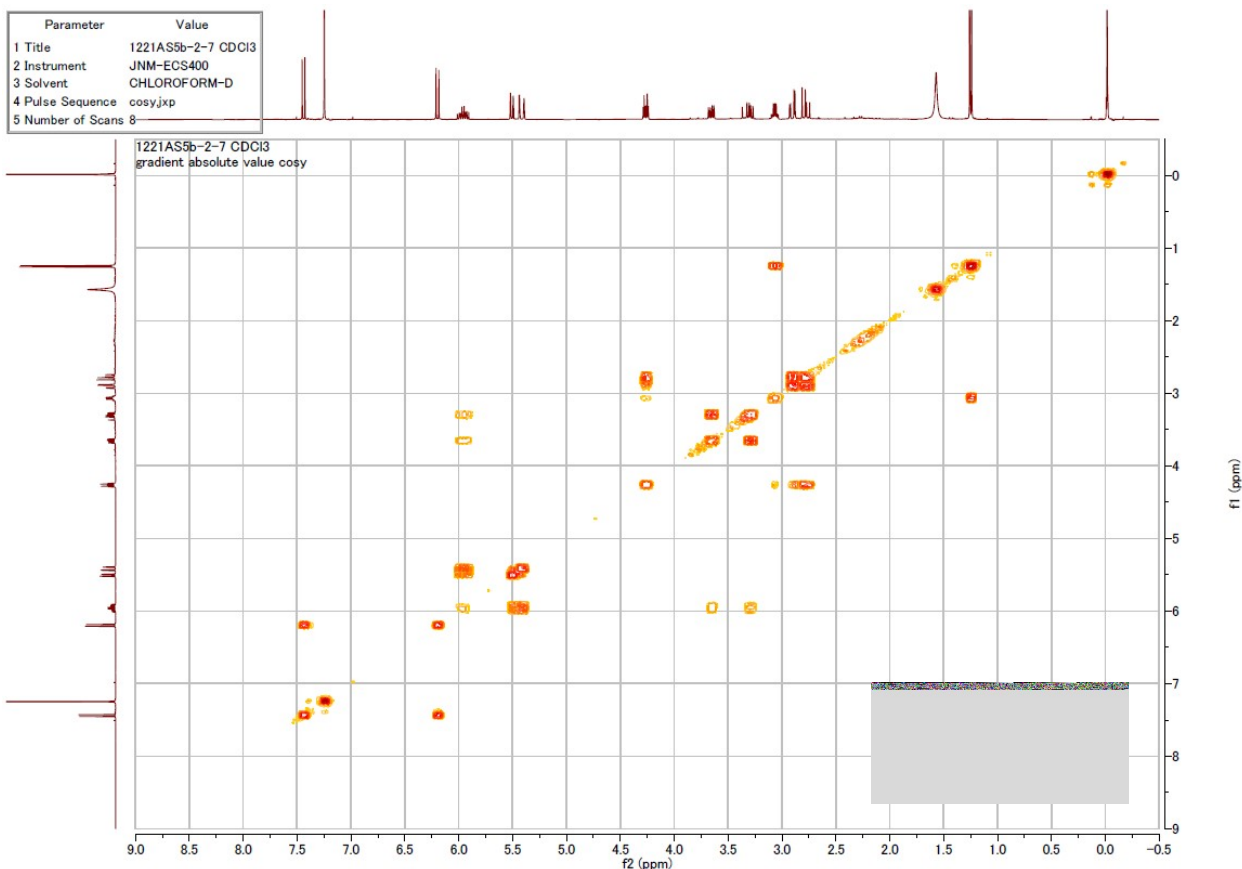
<sup>13</sup>C-NMR (100 MHz) spectroscopic data of **8c**. Measured in CDCl<sub>3</sub>.



HMQC NMR (400 MHz) spectroscopic data of **8c**. Measured in  $\text{CDCl}_3$ .

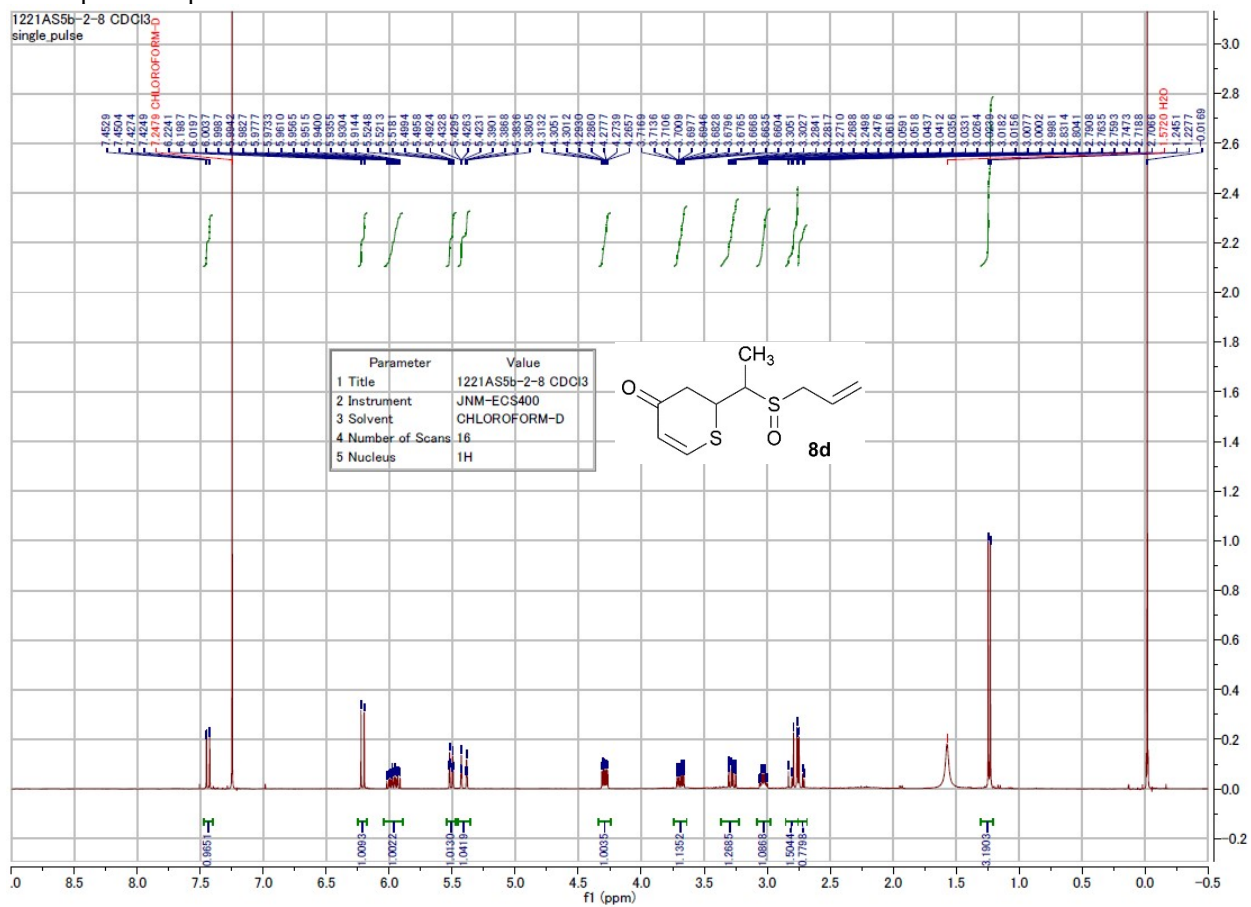


HMBC NMR (400 MHz) spectroscopic data of **8c**. Measured in  $\text{CDCl}_3$ .



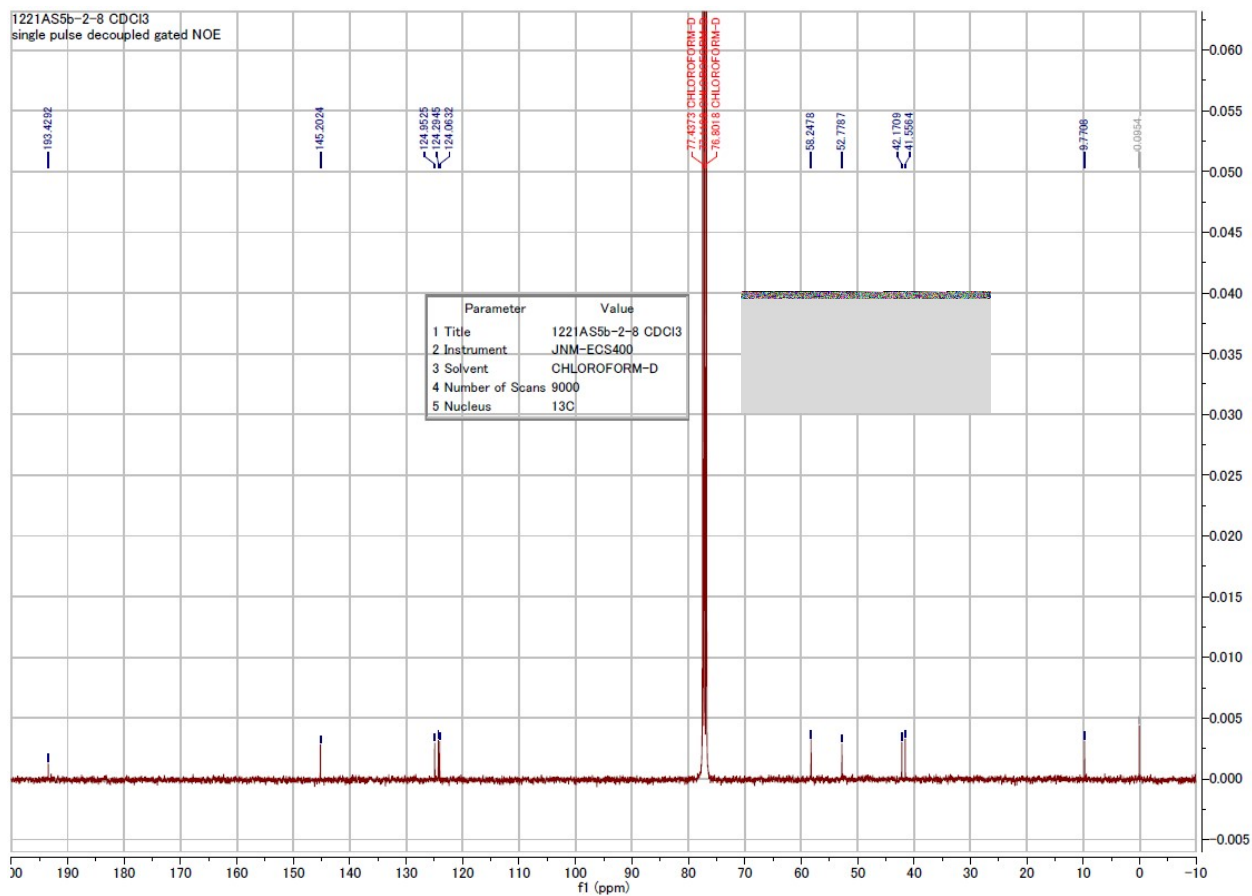
COSY NMR (400 MHz) spectroscopic data of **8c**. Measured in CDCl<sub>3</sub>.

NMR spectroscopic data of **8d**

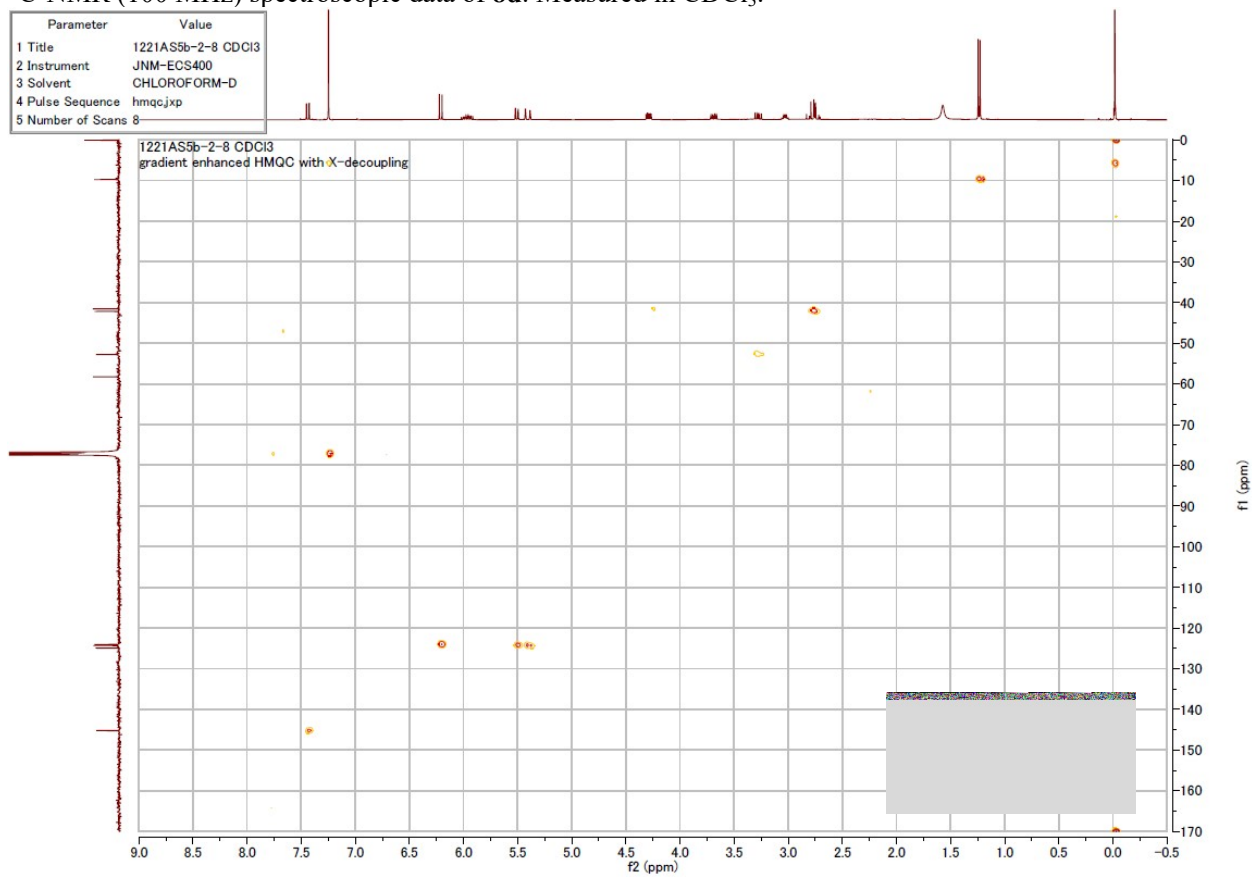


<sup>1</sup>H-NMR (400 MHz) spectroscopic data of **8d**. Measured in CDCl<sub>3</sub>.

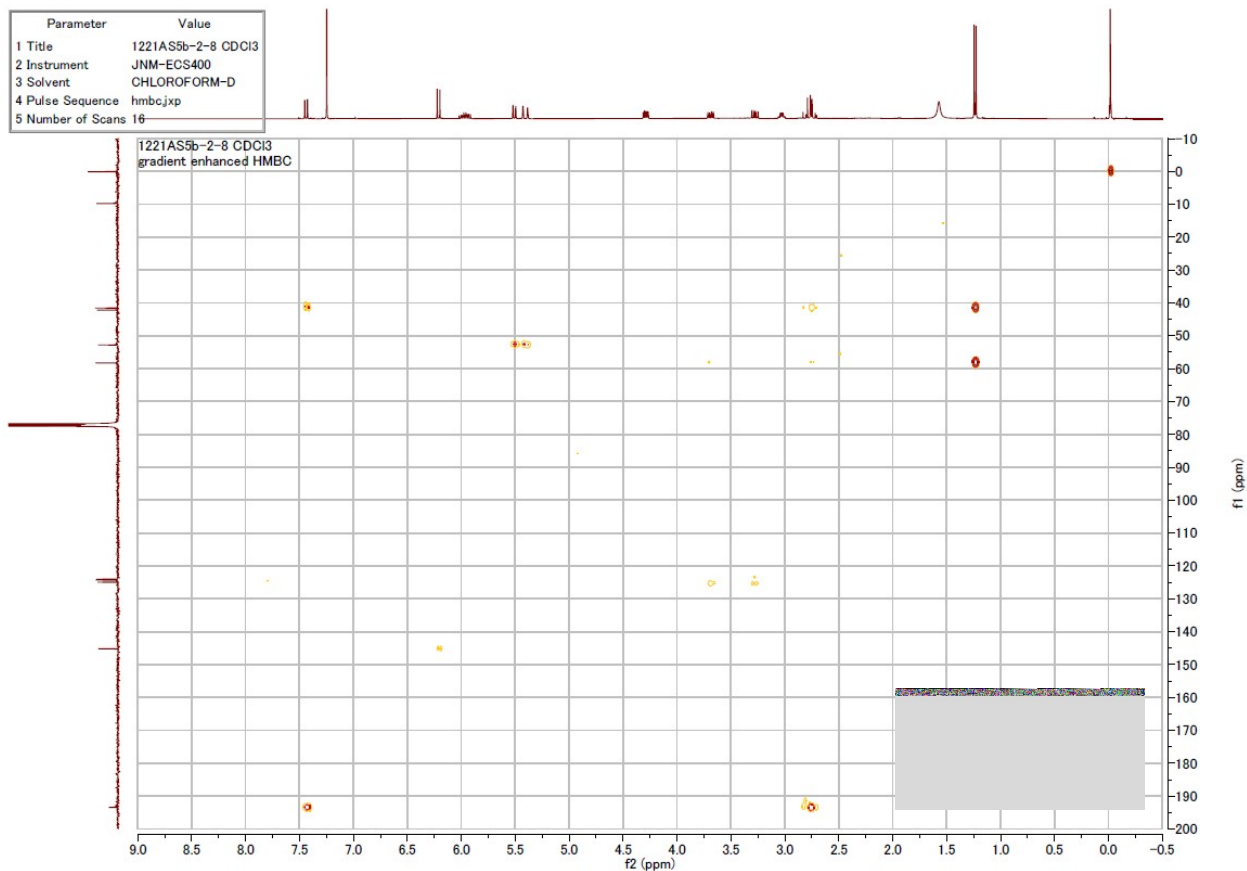




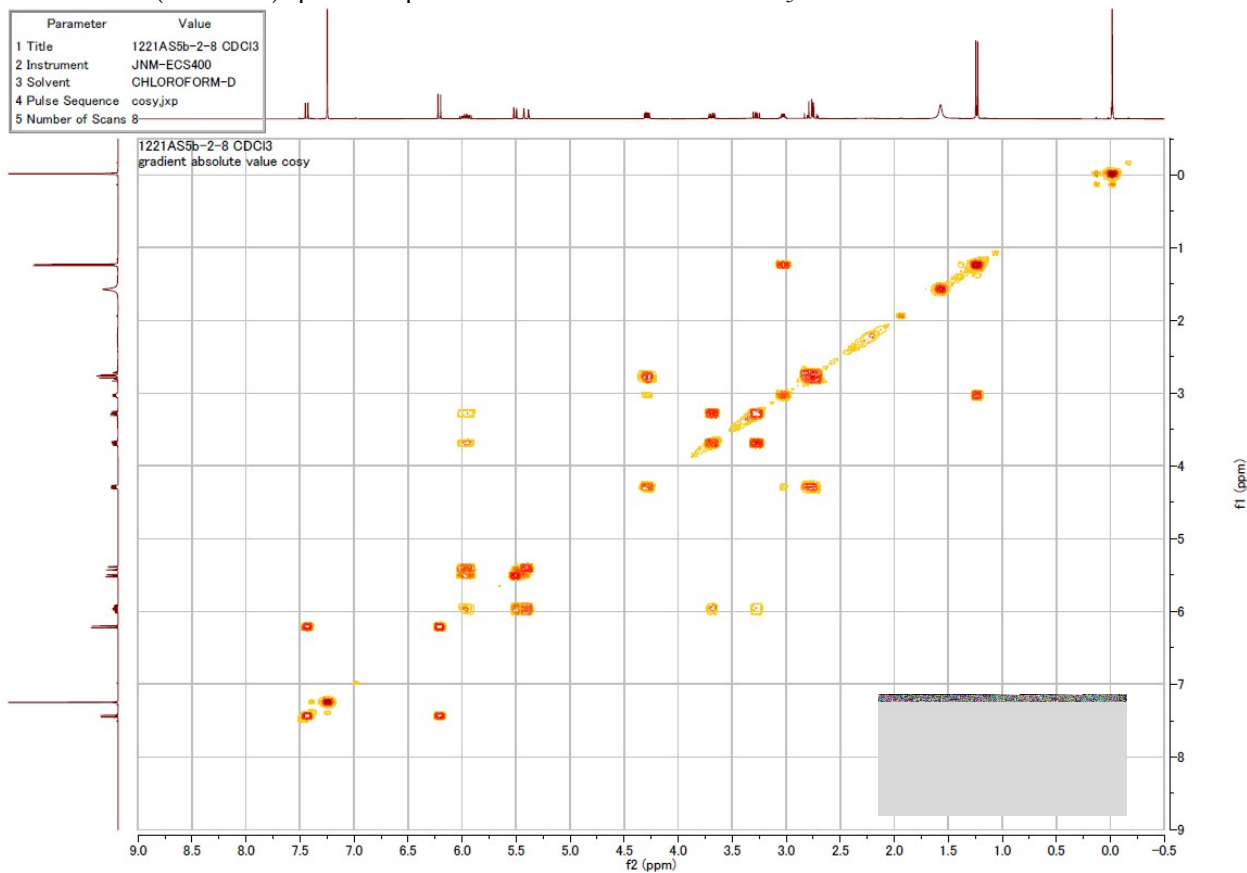
<sup>13</sup>C-NMR (100 MHz) spectroscopic data of **8d**. Measured in CDCl<sub>3</sub>.



HMQC NMR (400 MHz) spectroscopic data of **8d**. Measured in CDCl<sub>3</sub>.



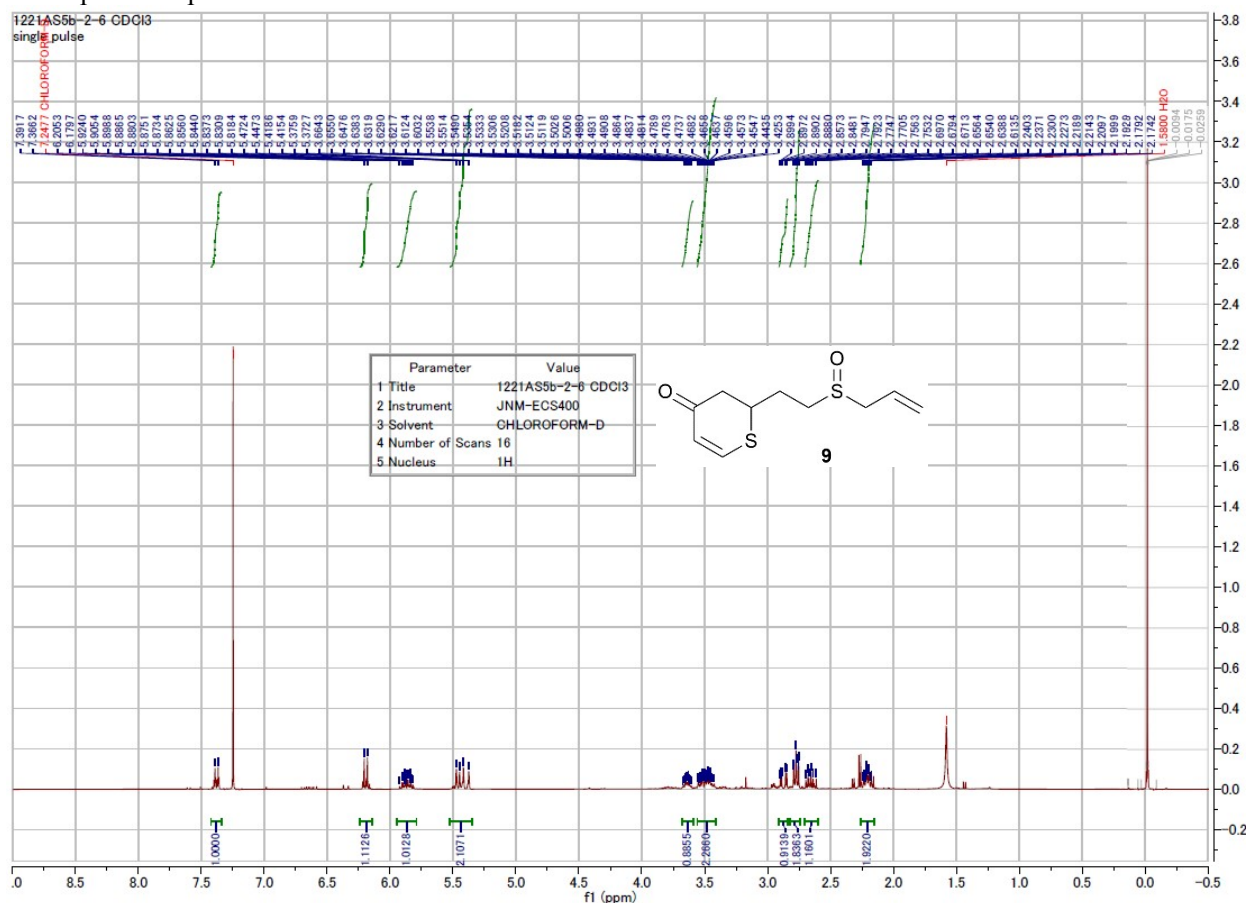
HMBC NMR (400 MHz) spectroscopic data of **8d**. Measured in CDCl<sub>3</sub>.



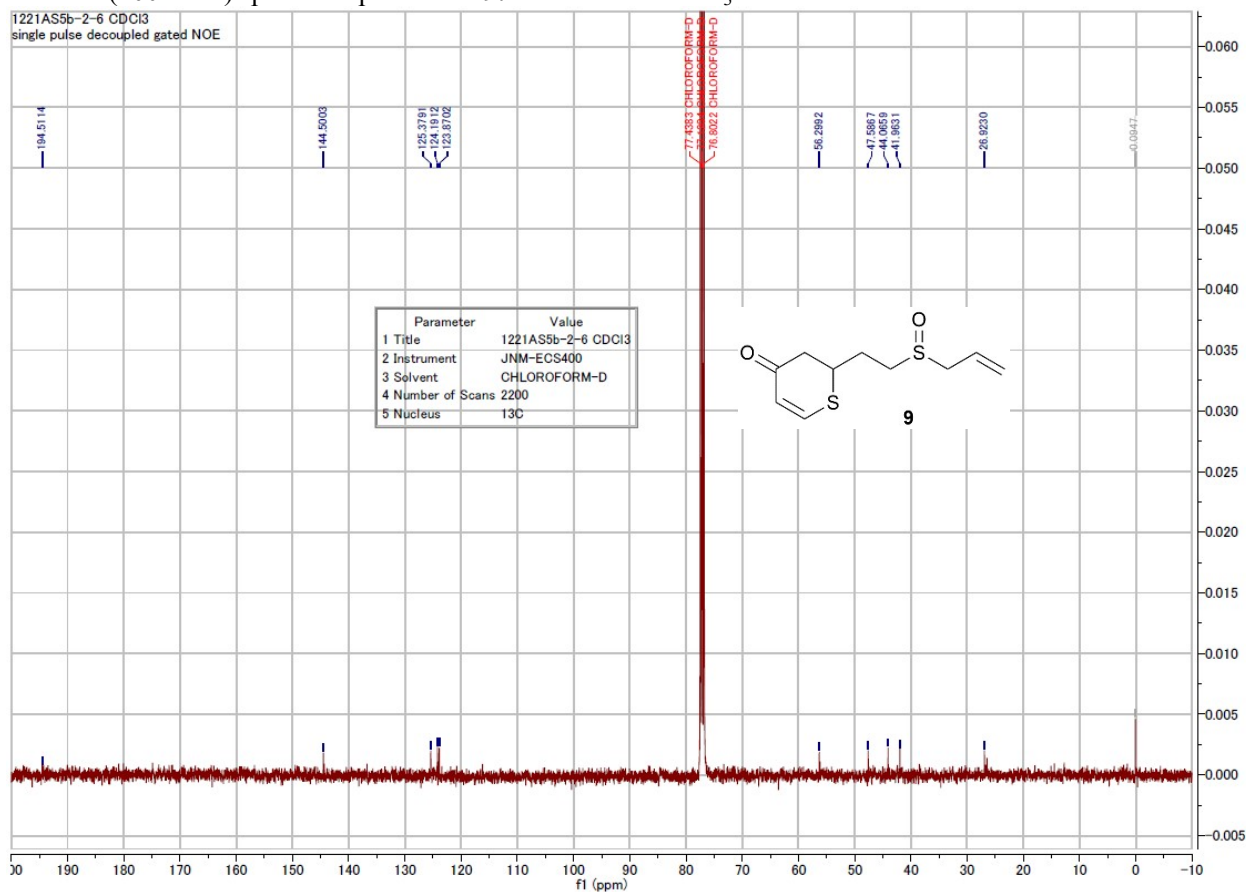
COSY NMR (400 MHz) spectroscopic data of **8d**. Measured in CDCl<sub>3</sub>.



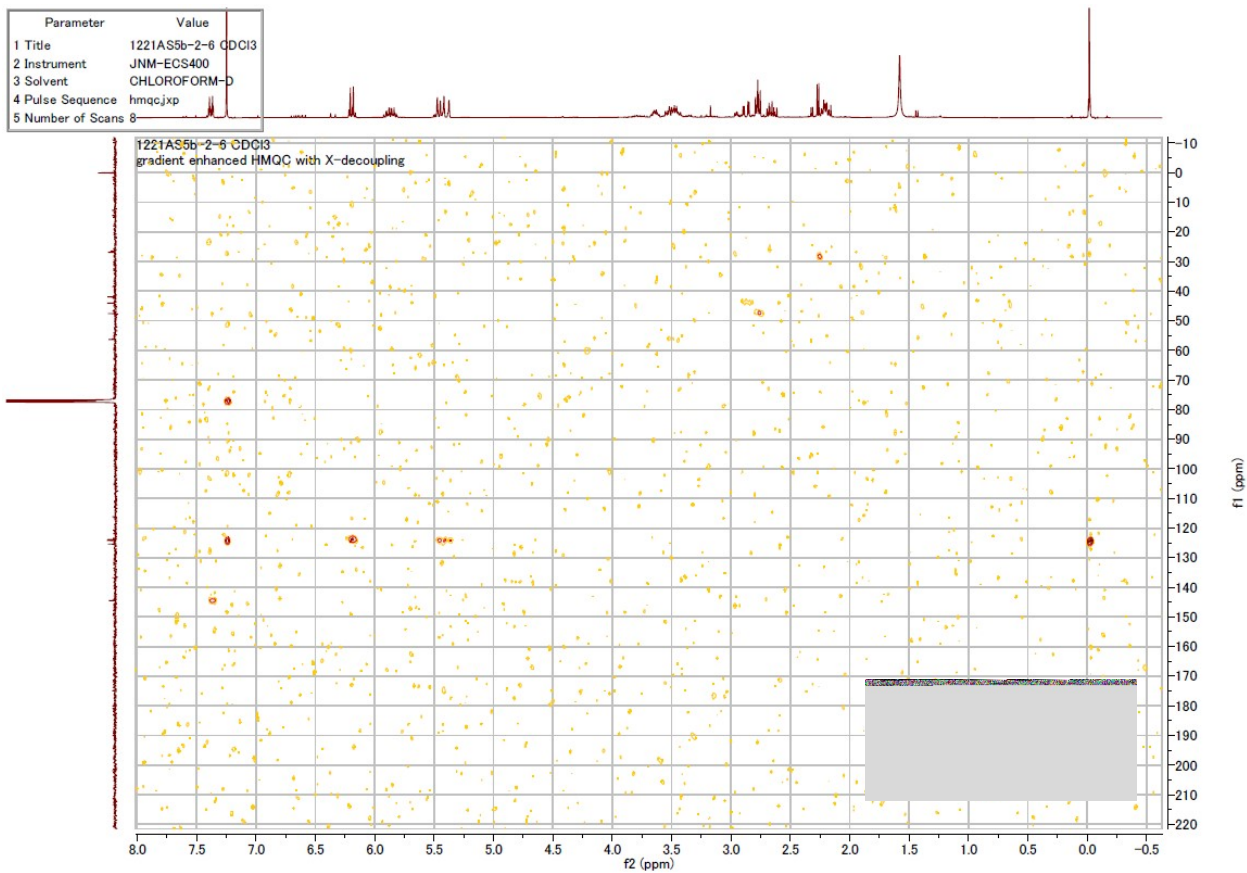
# NMR spectroscopic data of 9



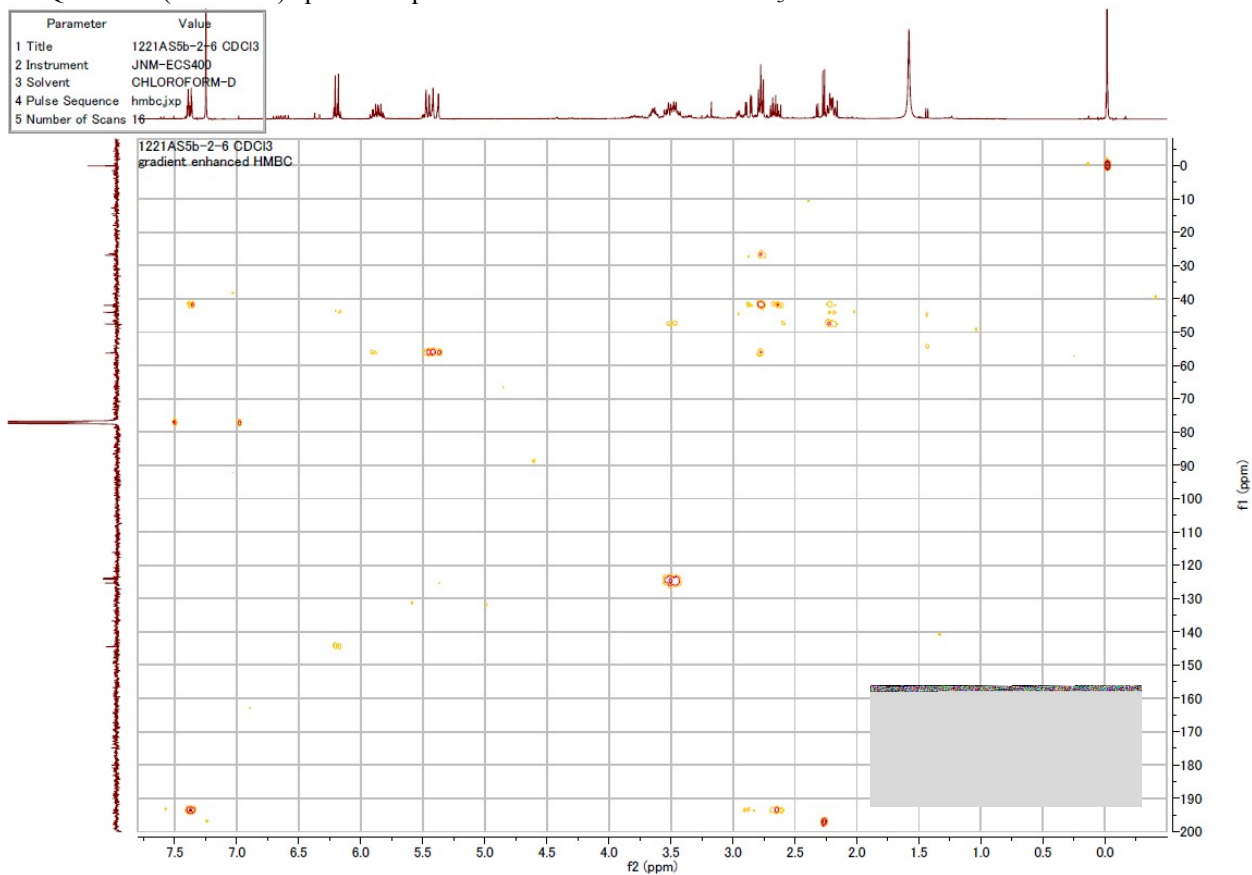
<sup>1</sup>H-NMR (400 MHz) spectroscopic data of 9. Measured in CDCl<sub>3</sub>.



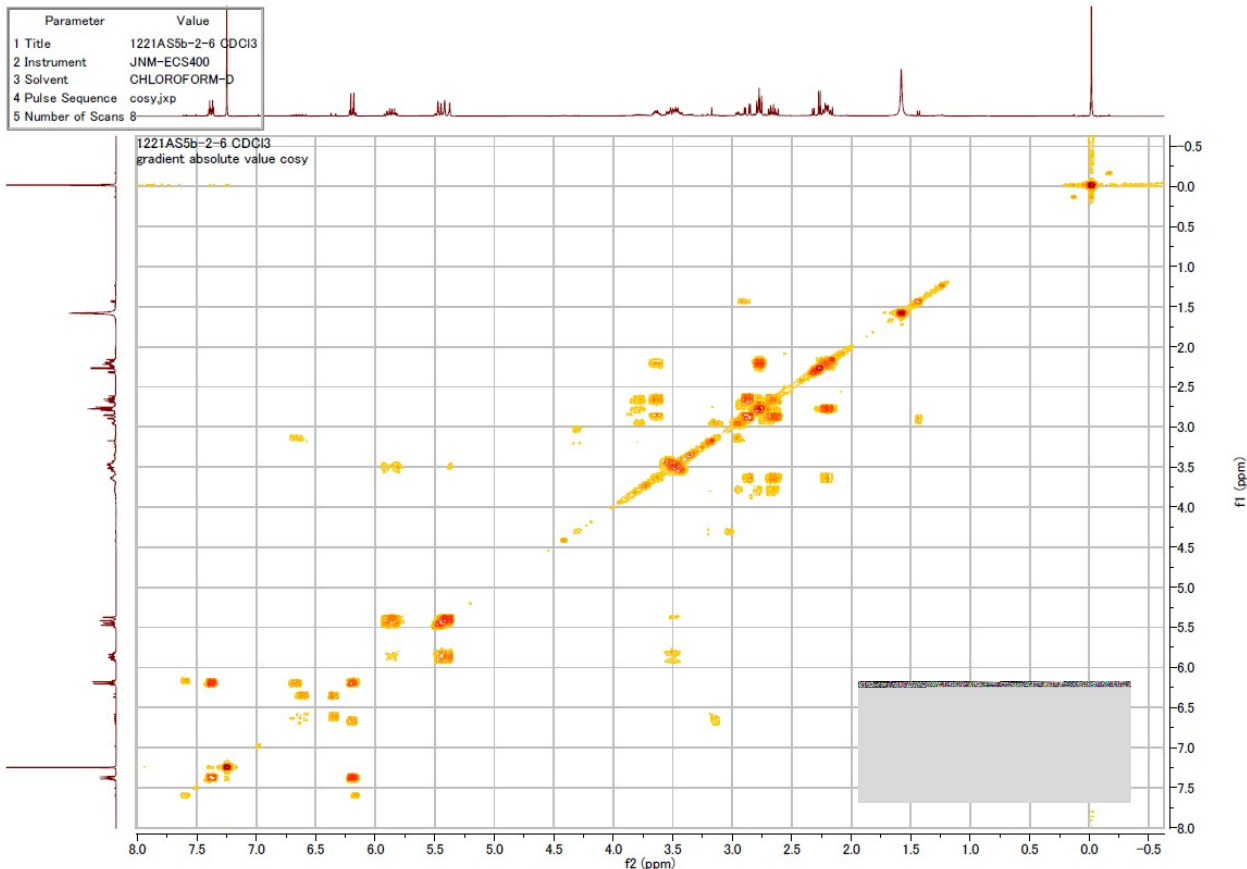
<sup>13</sup>C-NMR (100 MHz) spectroscopic data of 9. Measured in CDCl<sub>3</sub>.



HMQC NMR (400 MHz) spectroscopic data of **9**. Measured in  $\text{CDCl}_3$ .

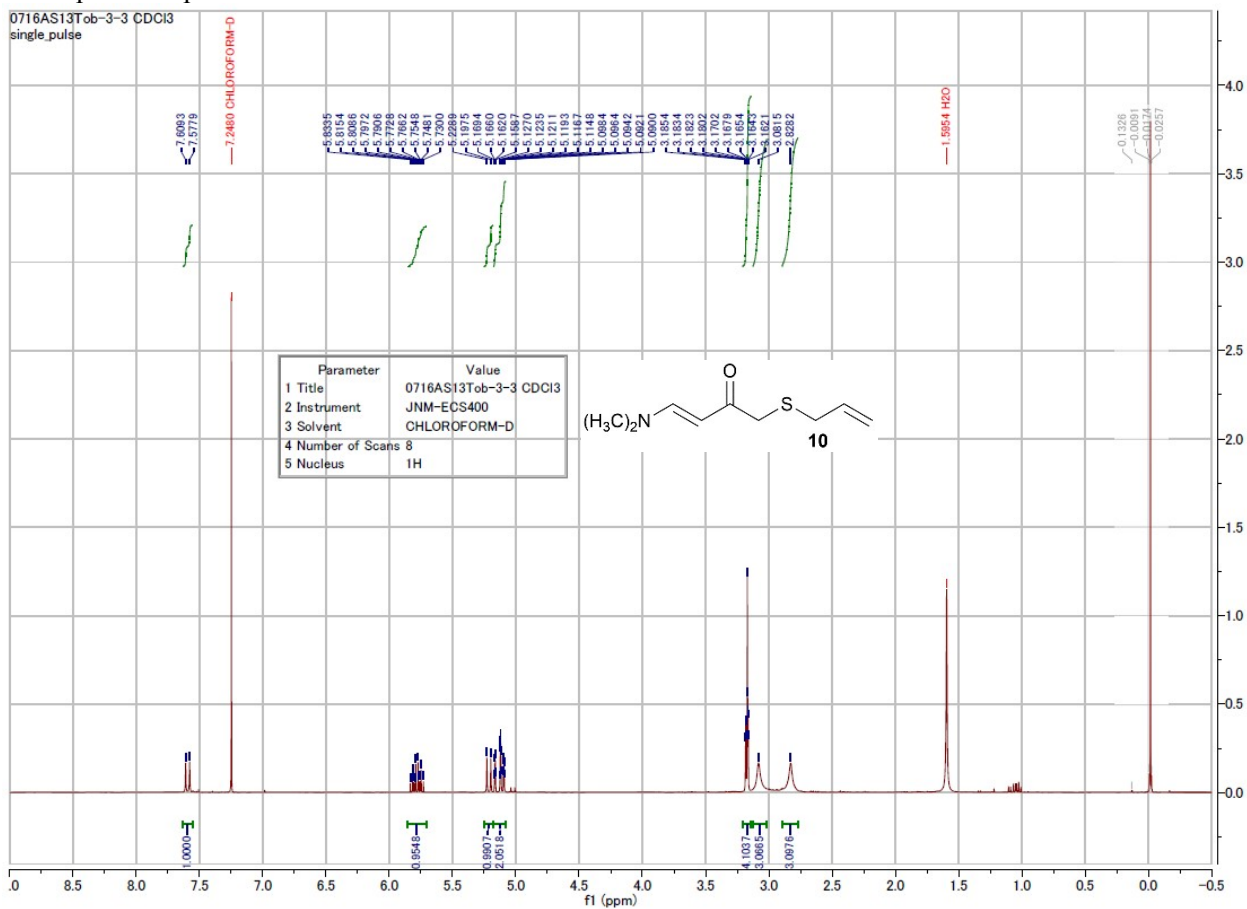


HMBC NMR (400 MHz) spectroscopic data of **9**. Measured in  $\text{CDCl}_3$ .

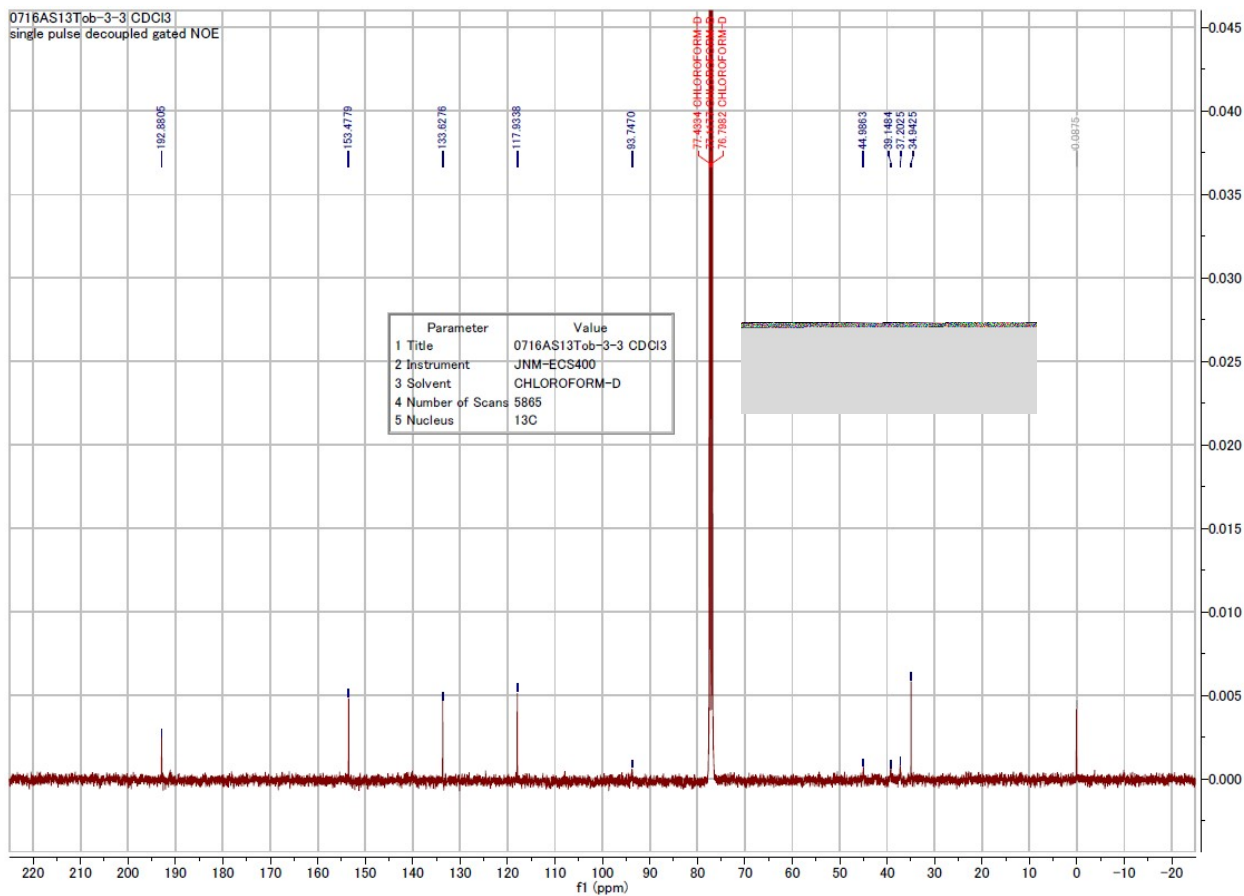


COSY NMR (400 MHz) spectroscopic data of **9**. Measured in CDCl<sub>3</sub>.

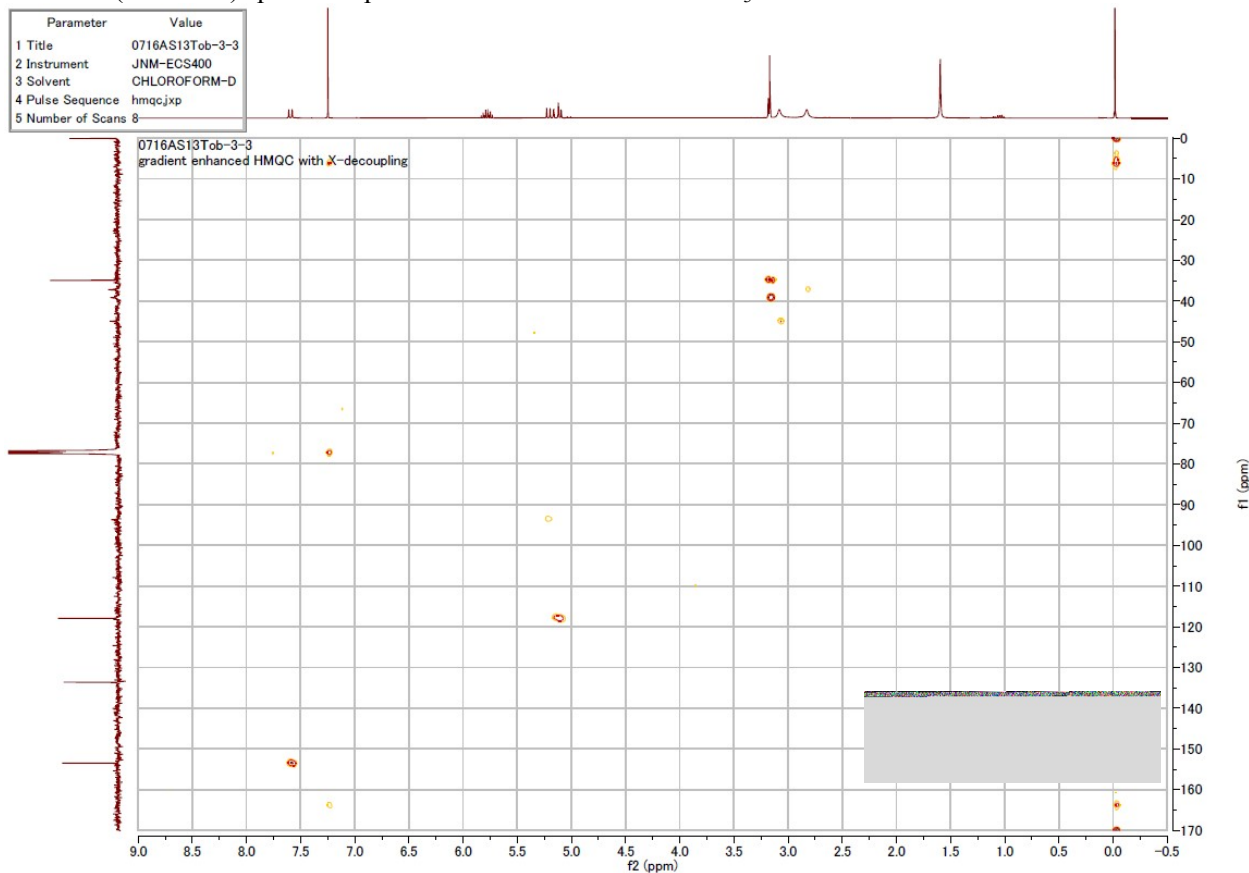
NMR spectroscopic data of **10**



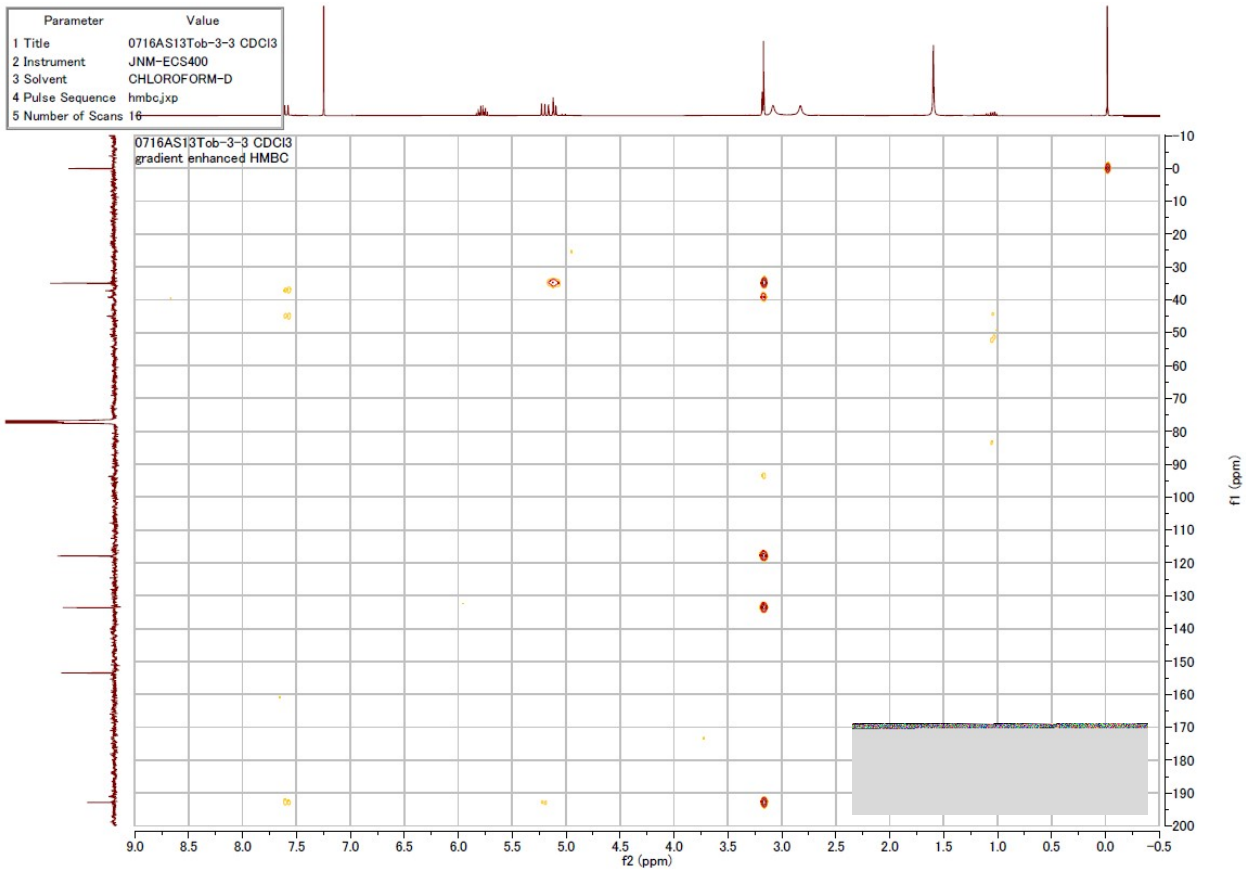
<sup>1</sup>H-NMR (400 MHz) spectroscopic data of **10**. Measured in CDCl<sub>3</sub>.



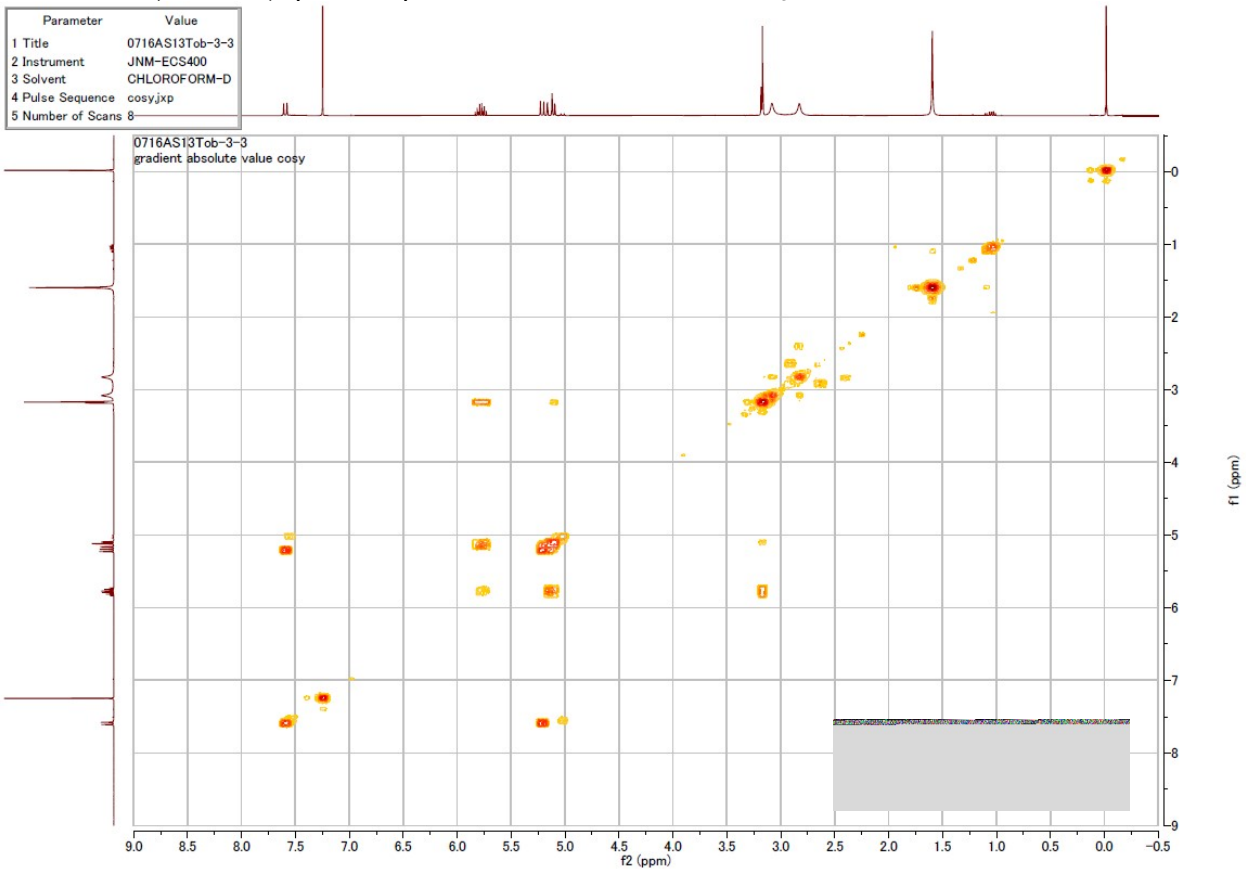
<sup>13</sup>C-NMR (100 MHz) spectroscopic data of **10**. Measured in CDCl<sub>3</sub>.



HMQC NMR (400 MHz) spectroscopic data of **10**. Measured in CDCl<sub>3</sub>.



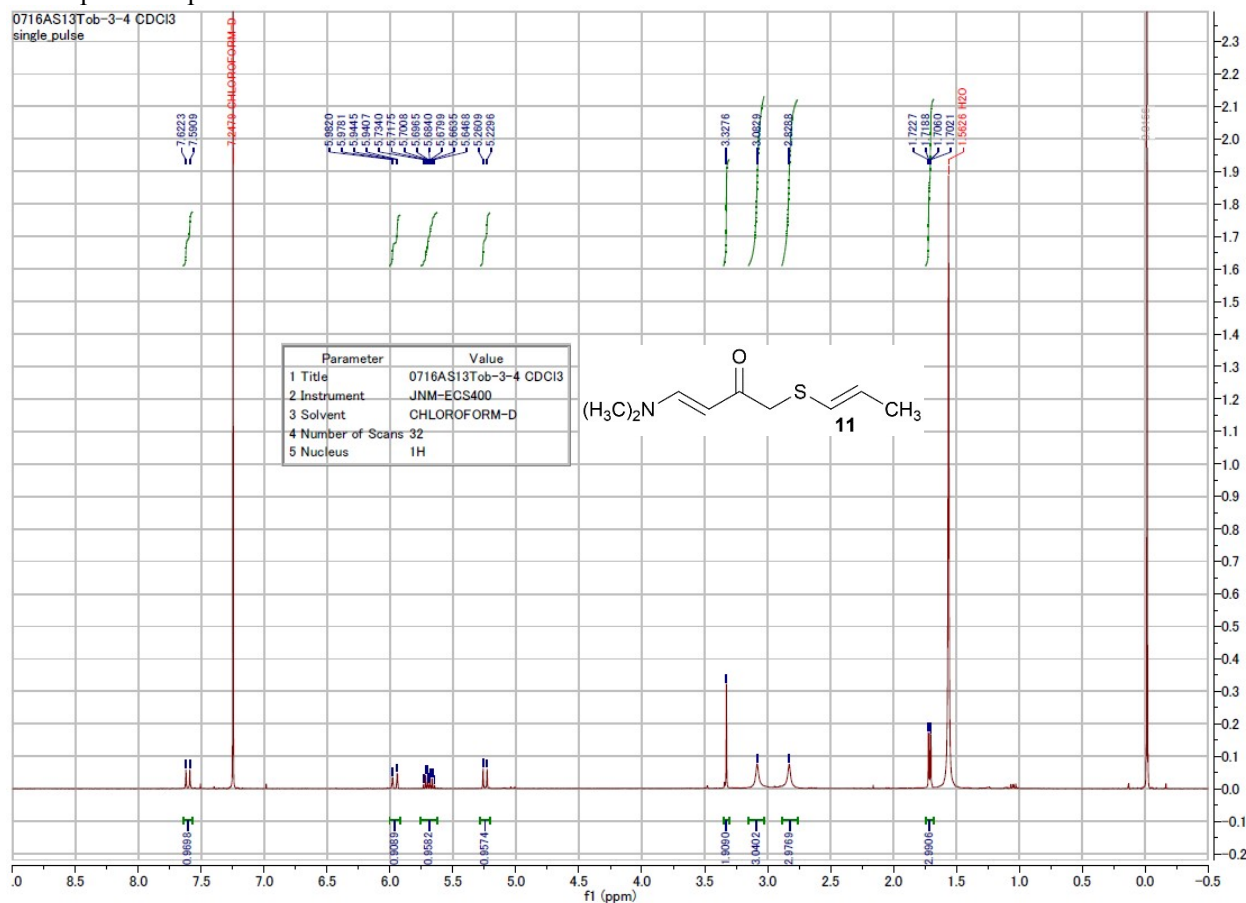
HMBC NMR (400 MHz) spectroscopic data of **10**. Measured in CDCl<sub>3</sub>.



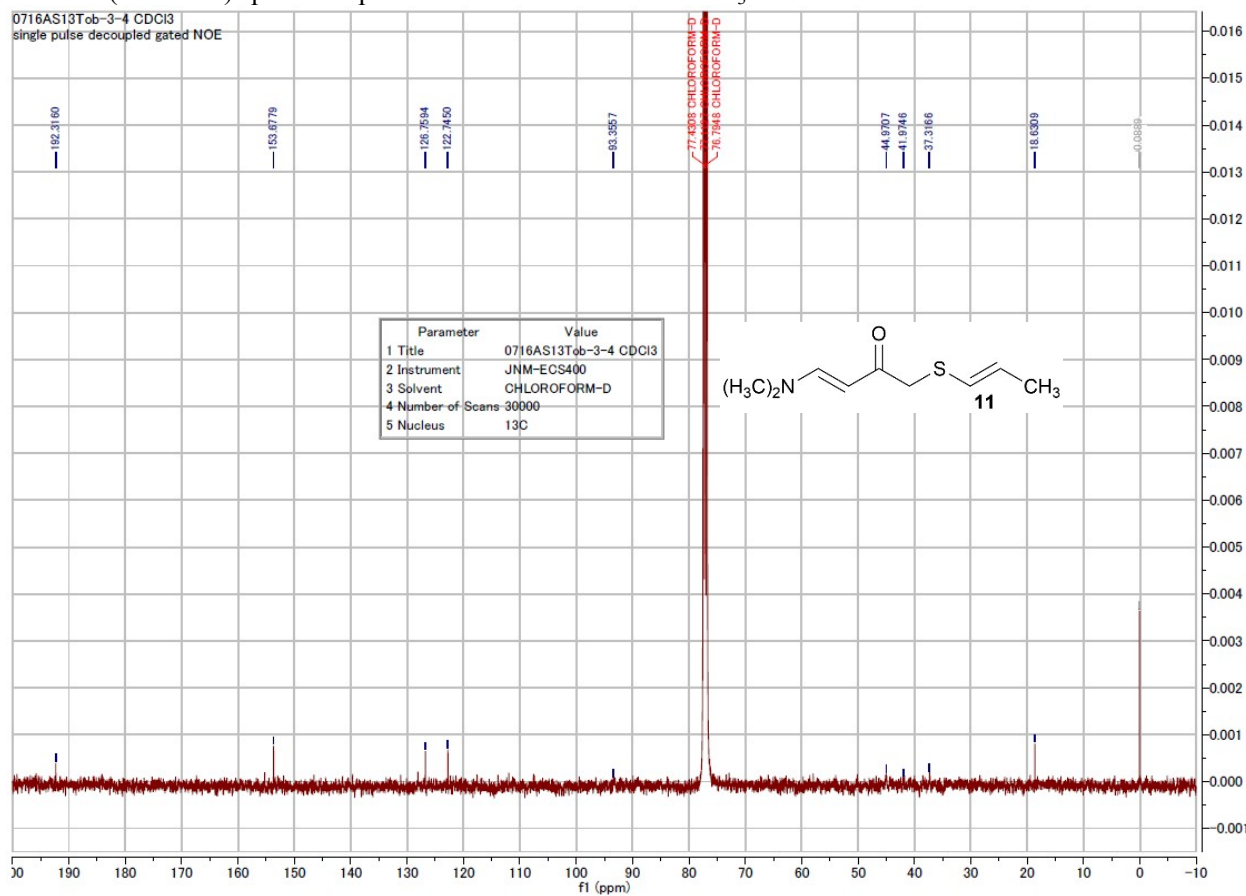
COSY NMR (400 MHz) spectroscopic data of **10**. Measured in CDCl<sub>3</sub>.



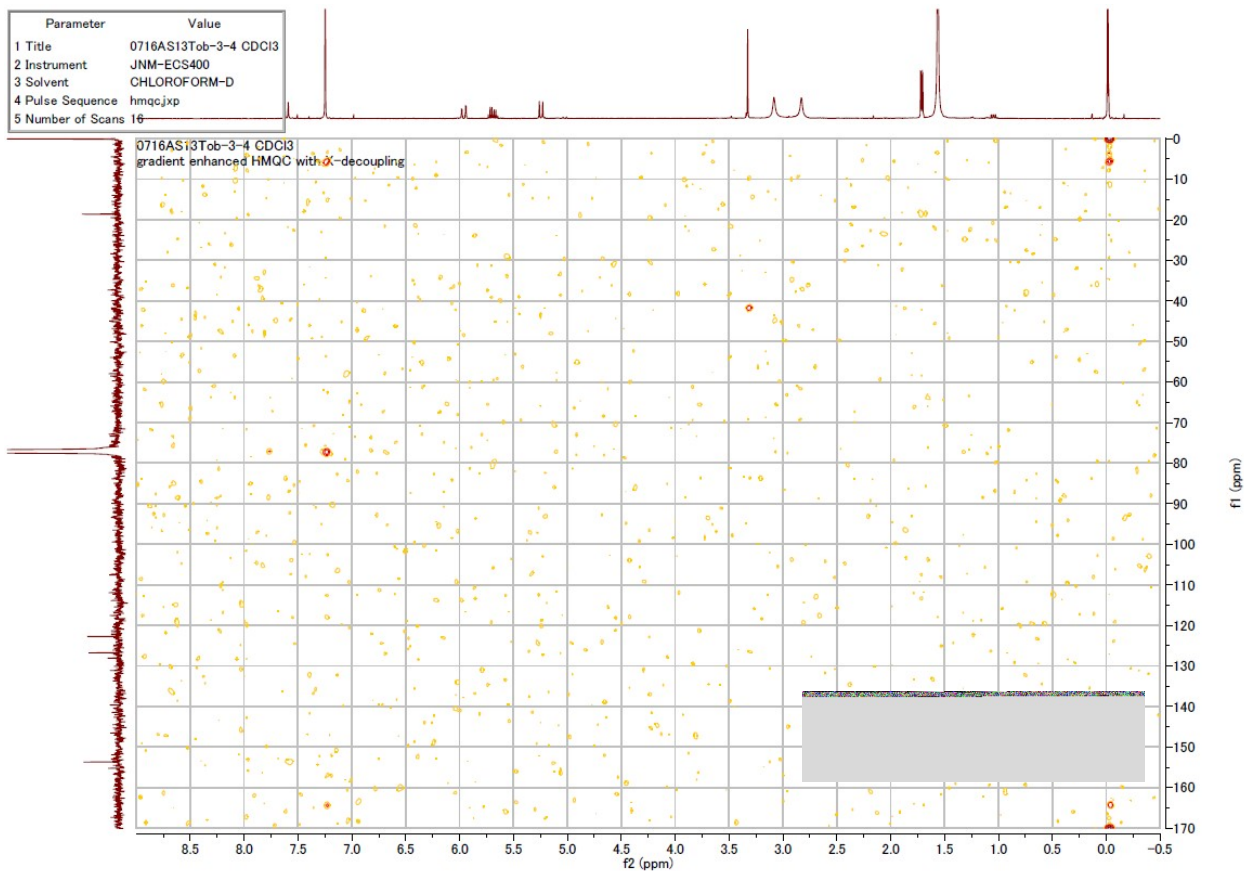
# NMR spectroscopic data of **11**



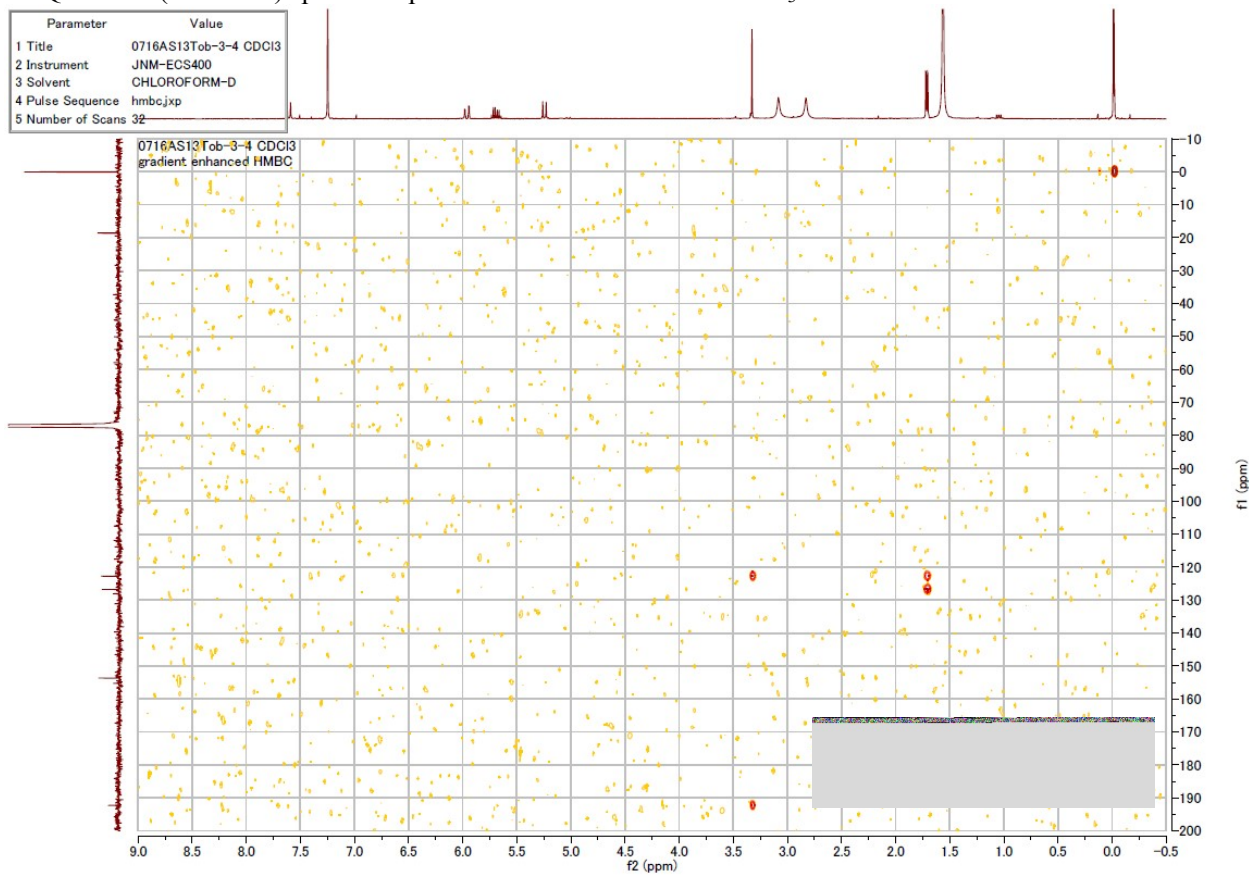
<sup>1</sup>H-NMR (400 MHz) spectroscopic data of **11**. Measured in CDCl<sub>3</sub>.



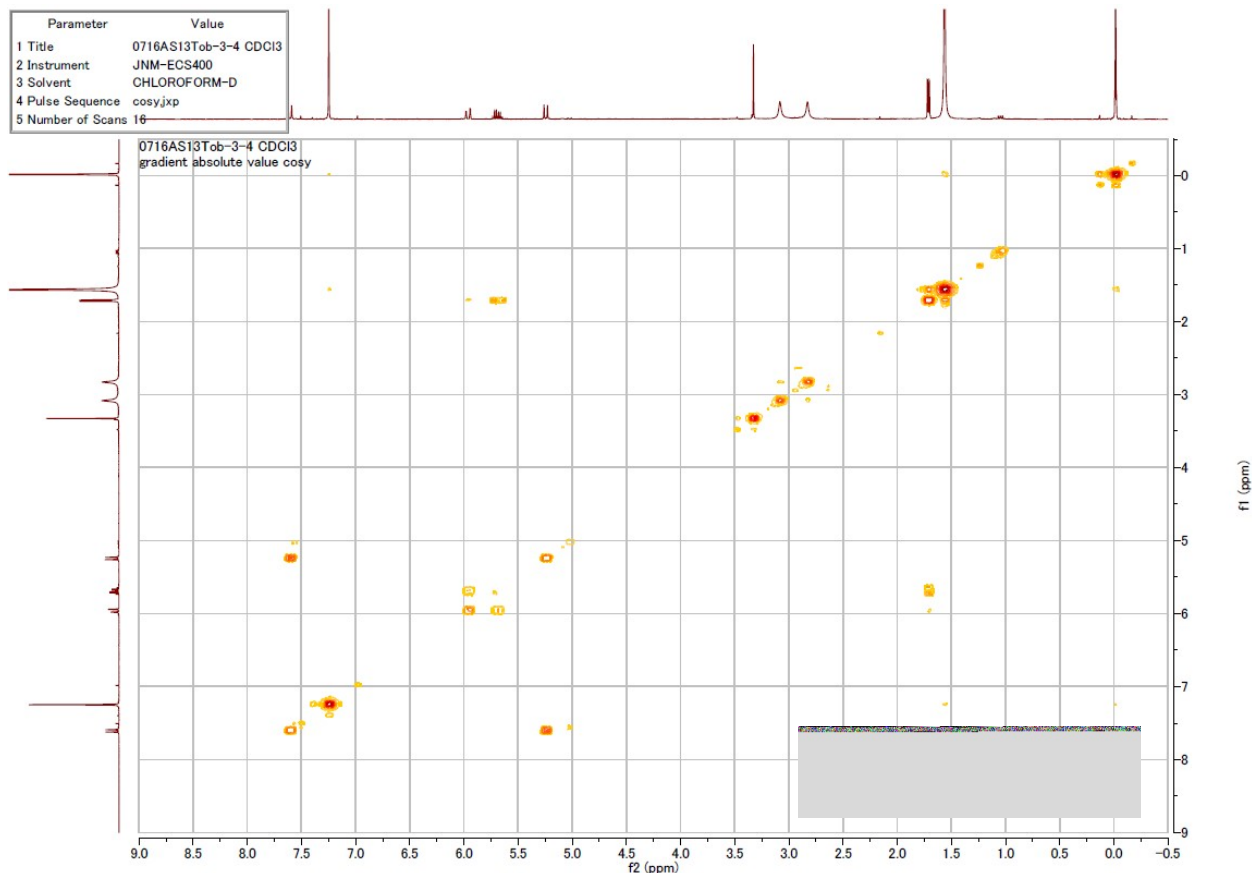
<sup>13</sup>C-NMR (100 MHz) spectroscopic data of **11**. Measured in CDCl<sub>3</sub>.



HMQC NMR (400 MHz) spectroscopic data of **11**. Measured in CDCl<sub>3</sub>.

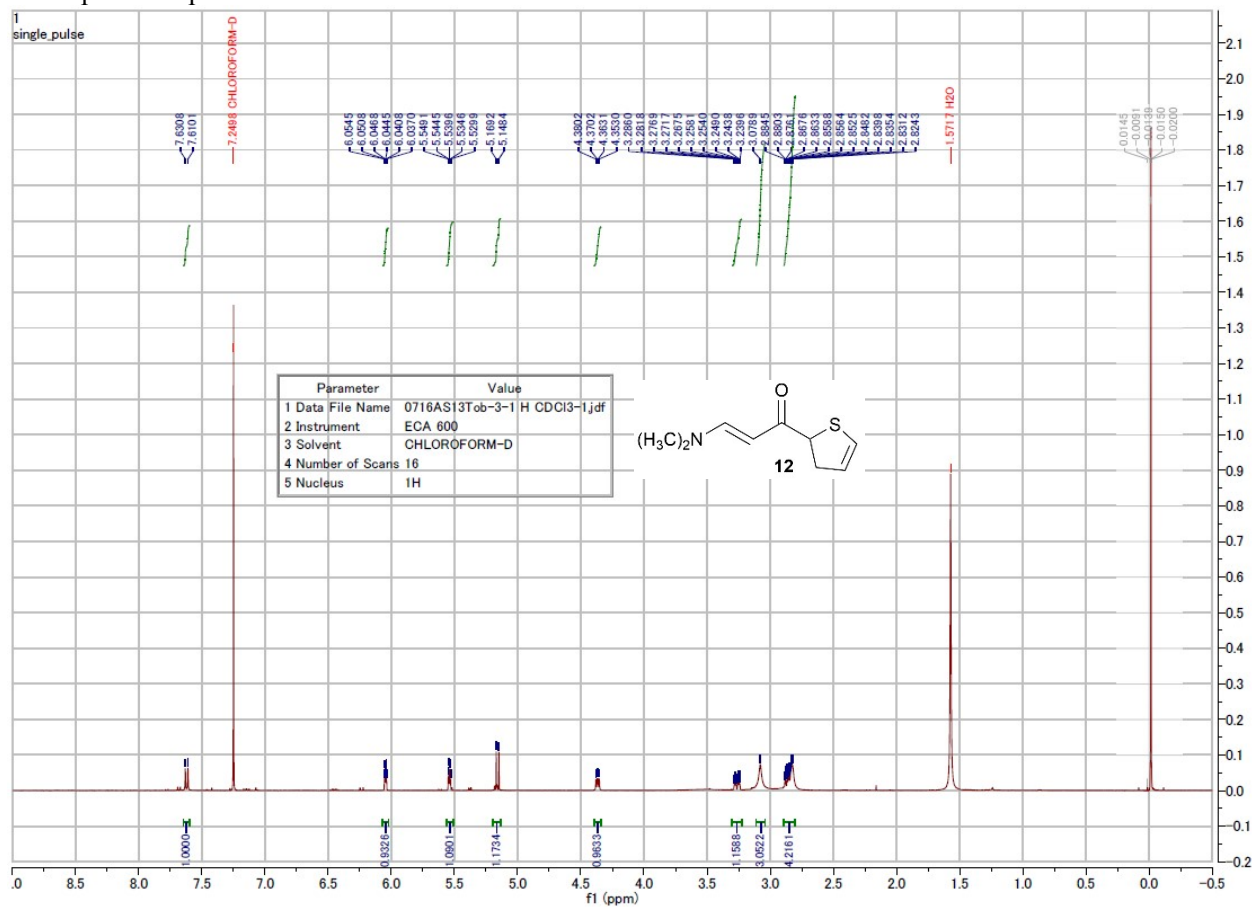


HMBC NMR (400 MHz) spectroscopic data of **11**. Measured in CDCl<sub>3</sub>.



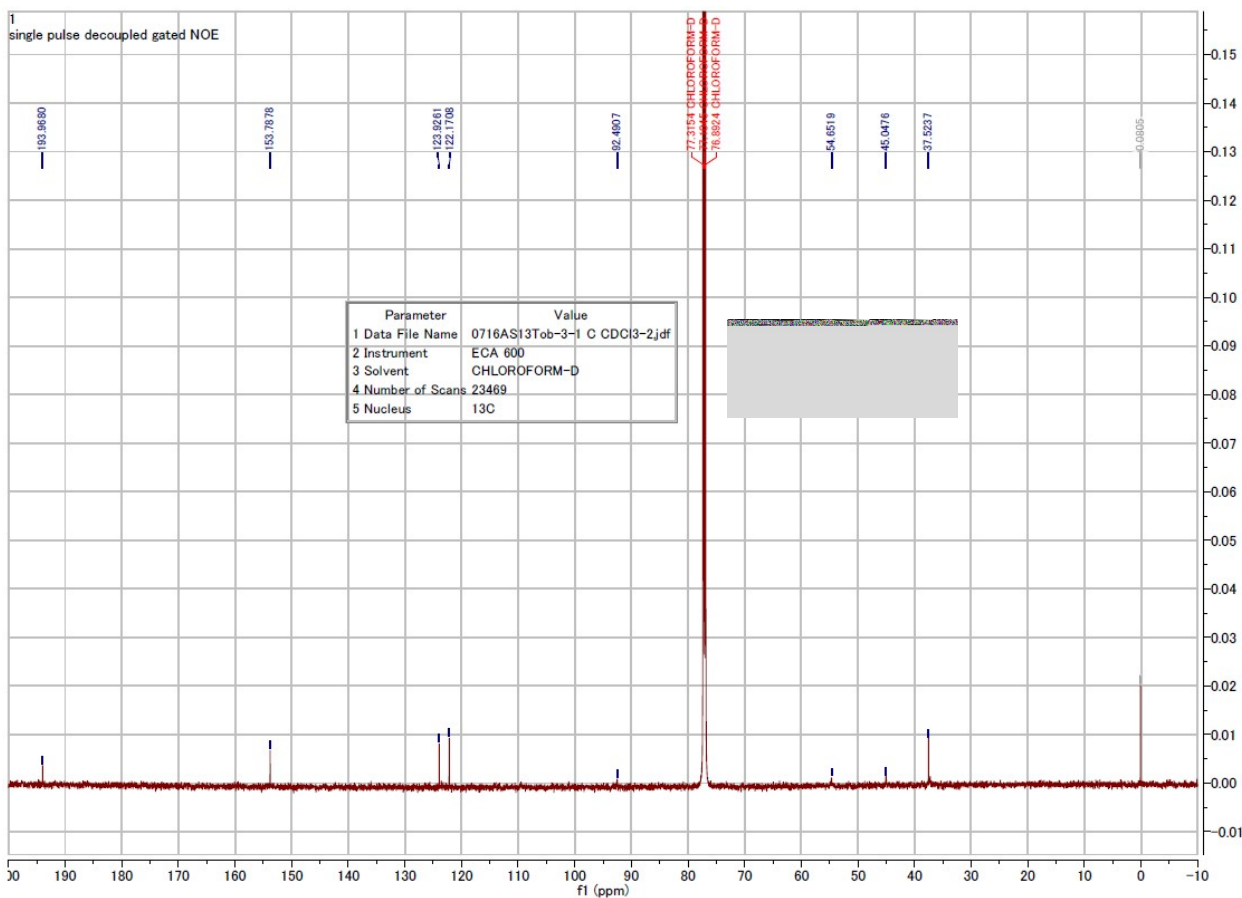
COSY NMR (400 MHz) spectroscopic data of **11**. Measured in CDCl<sub>3</sub>.

NMR spectroscopic data of **12**

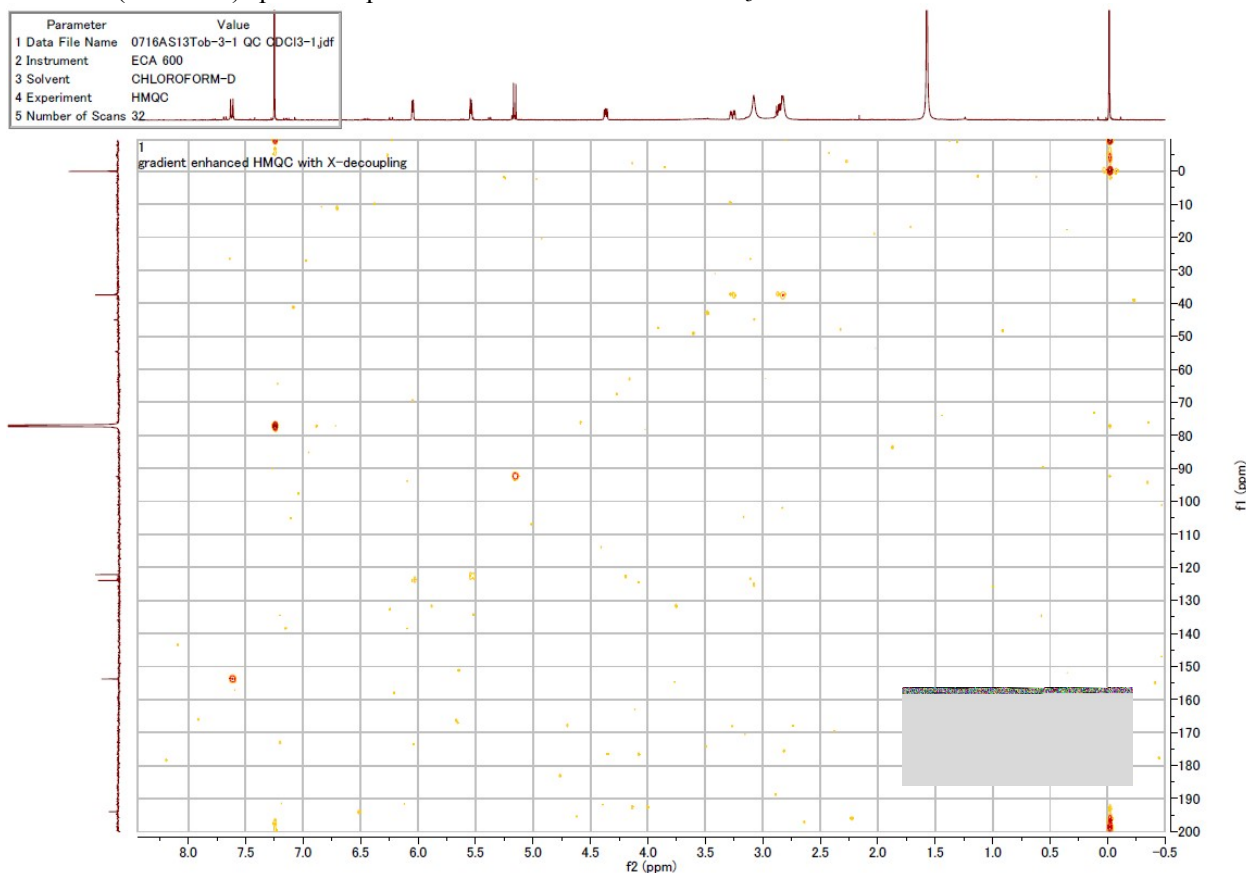


<sup>1</sup>H-NMR (600 MHz) spectroscopic data of **12**. Measured in CDCl<sub>3</sub>.

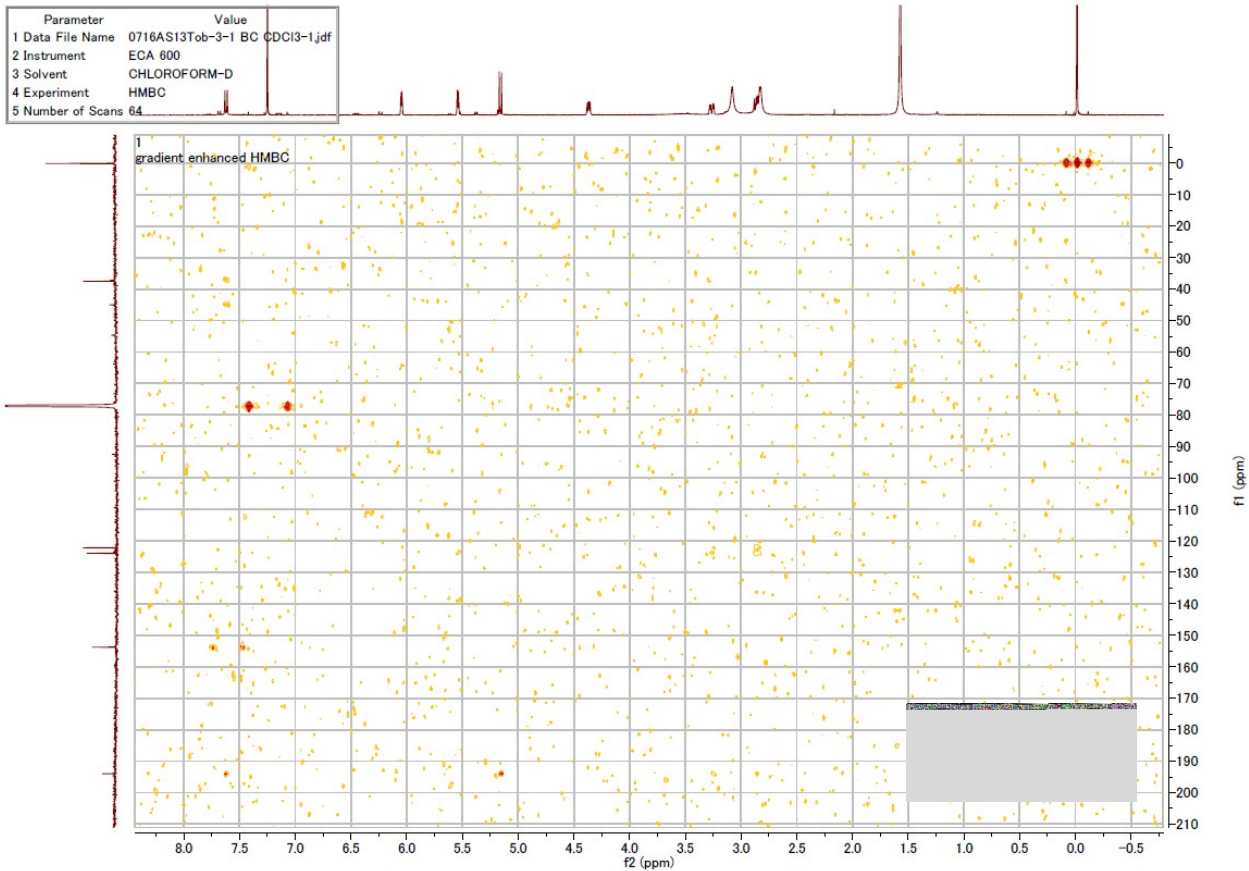




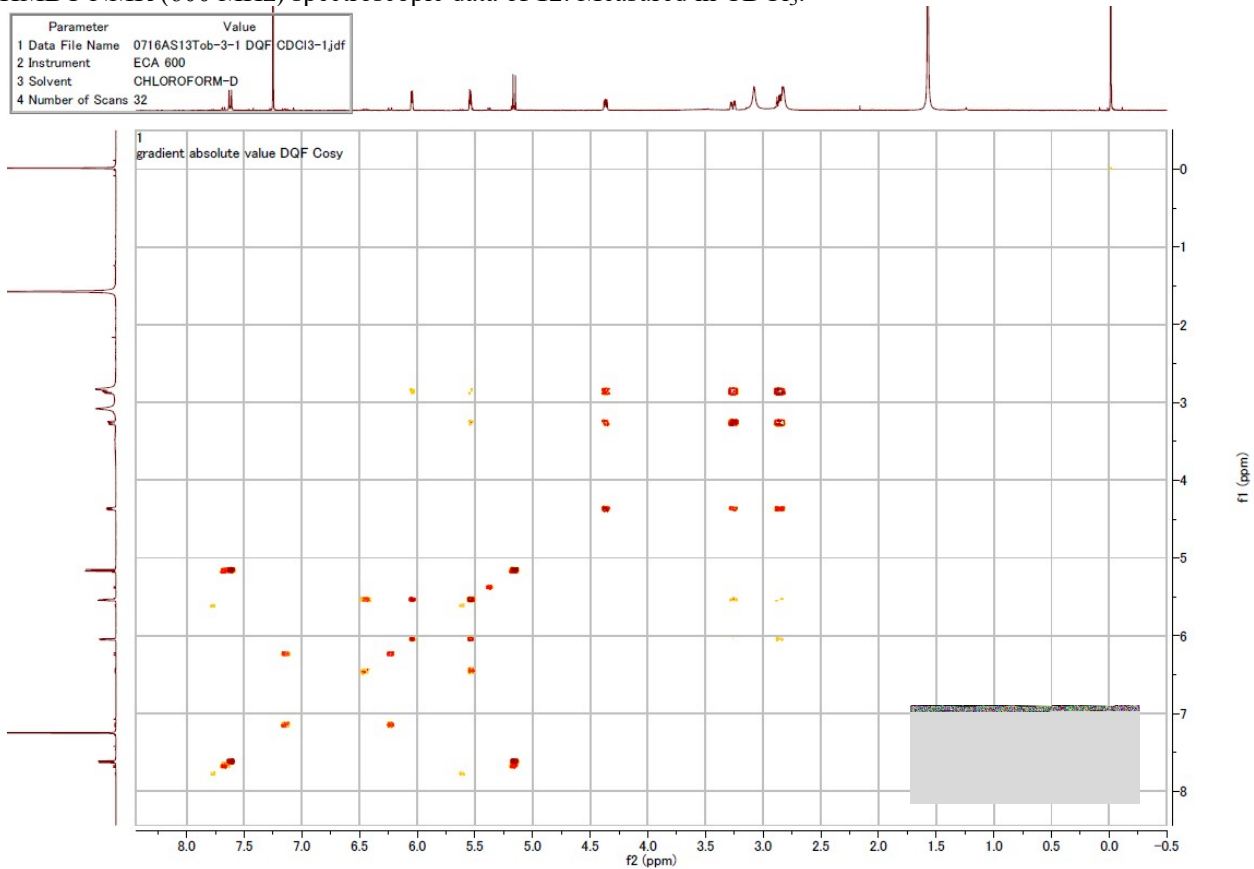
$^{13}\text{C}$ -NMR (150 MHz) spectroscopic data of **12**. Measured in  $\text{CDCl}_3$ .



HMQC NMR (600 MHz) spectroscopic data of **12**. Measured in  $\text{CDCl}_3$ .

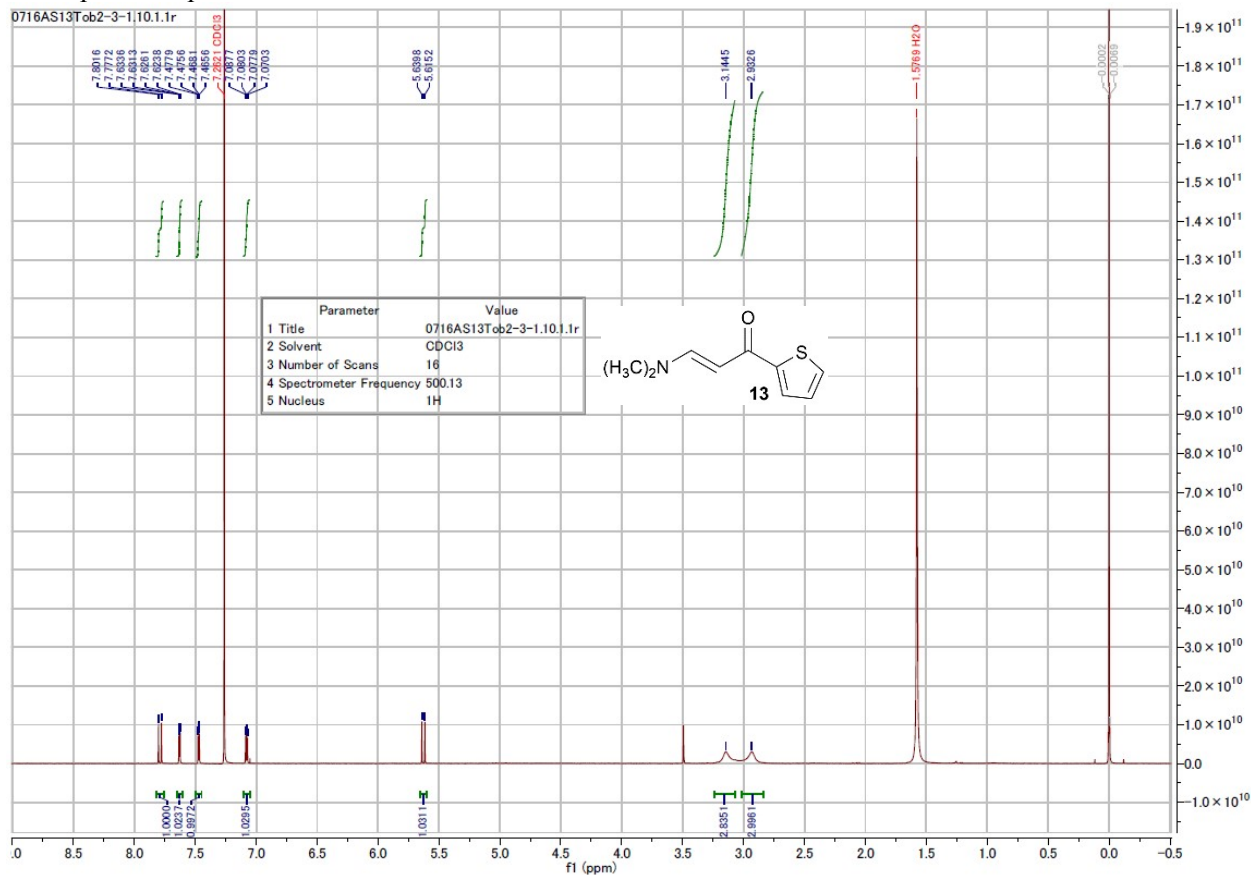


HMBC NMR (600 MHz) spectroscopic data of **12**. Measured in  $\text{CDCl}_3$ .

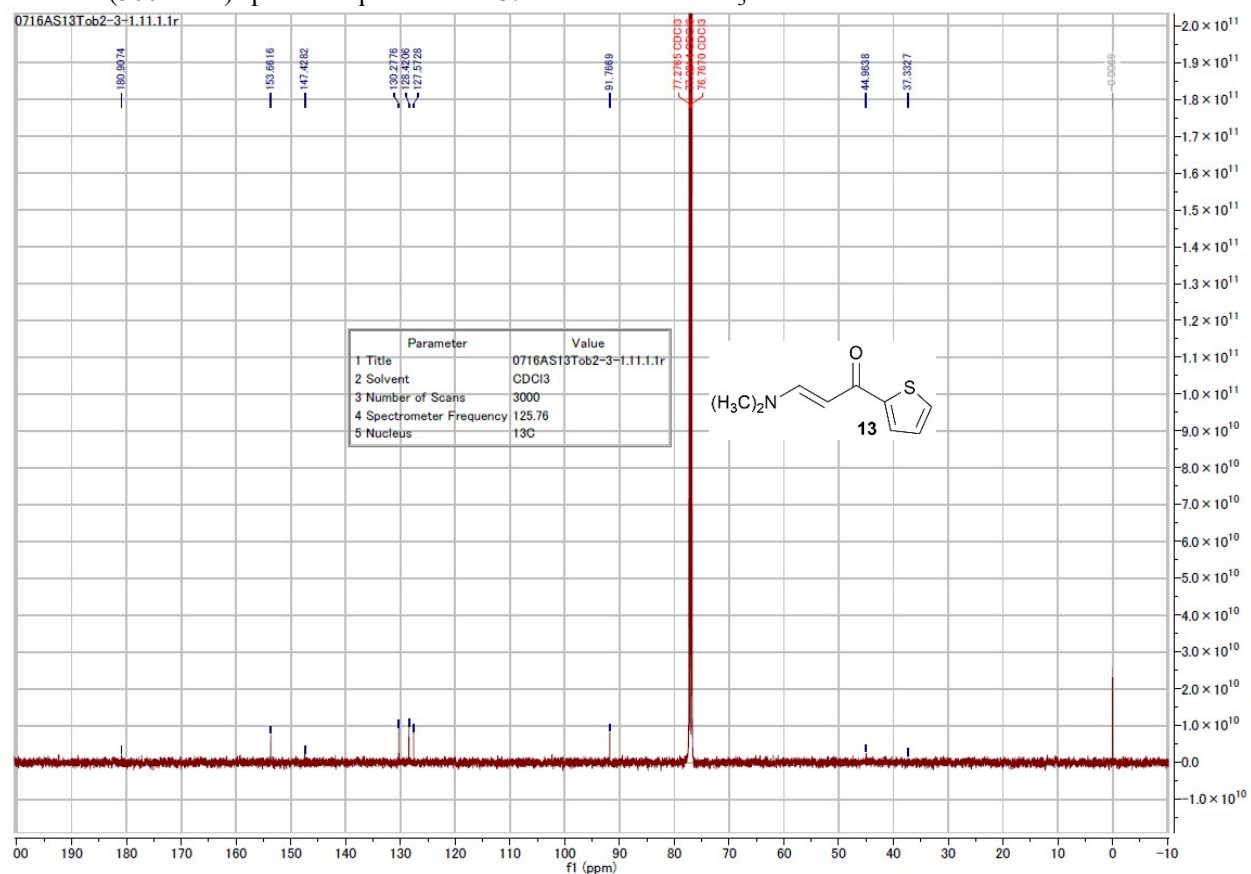


COSY NMR (600 MHz) spectroscopic data of **12**. Measured in  $\text{CDCl}_3$ .

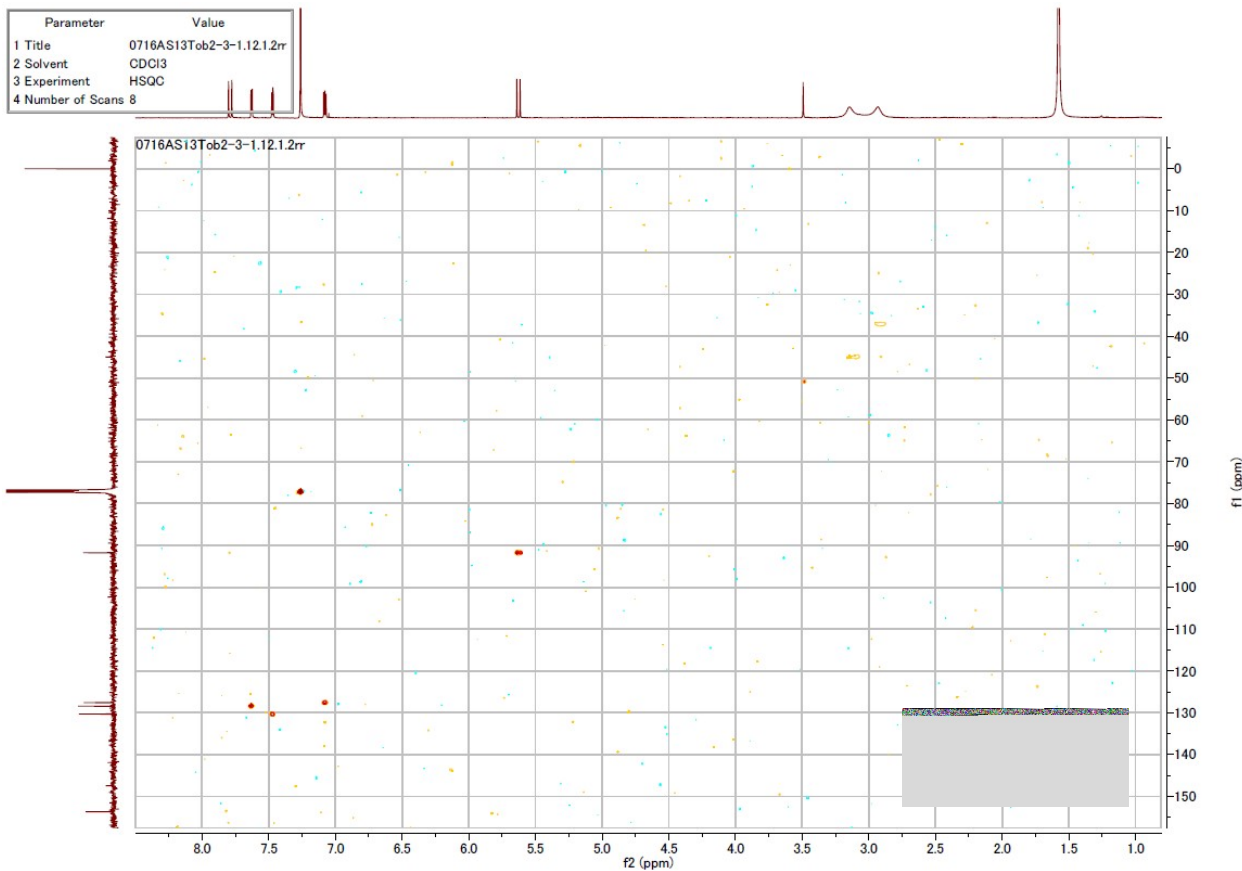
# NMR spectroscopic data of 13



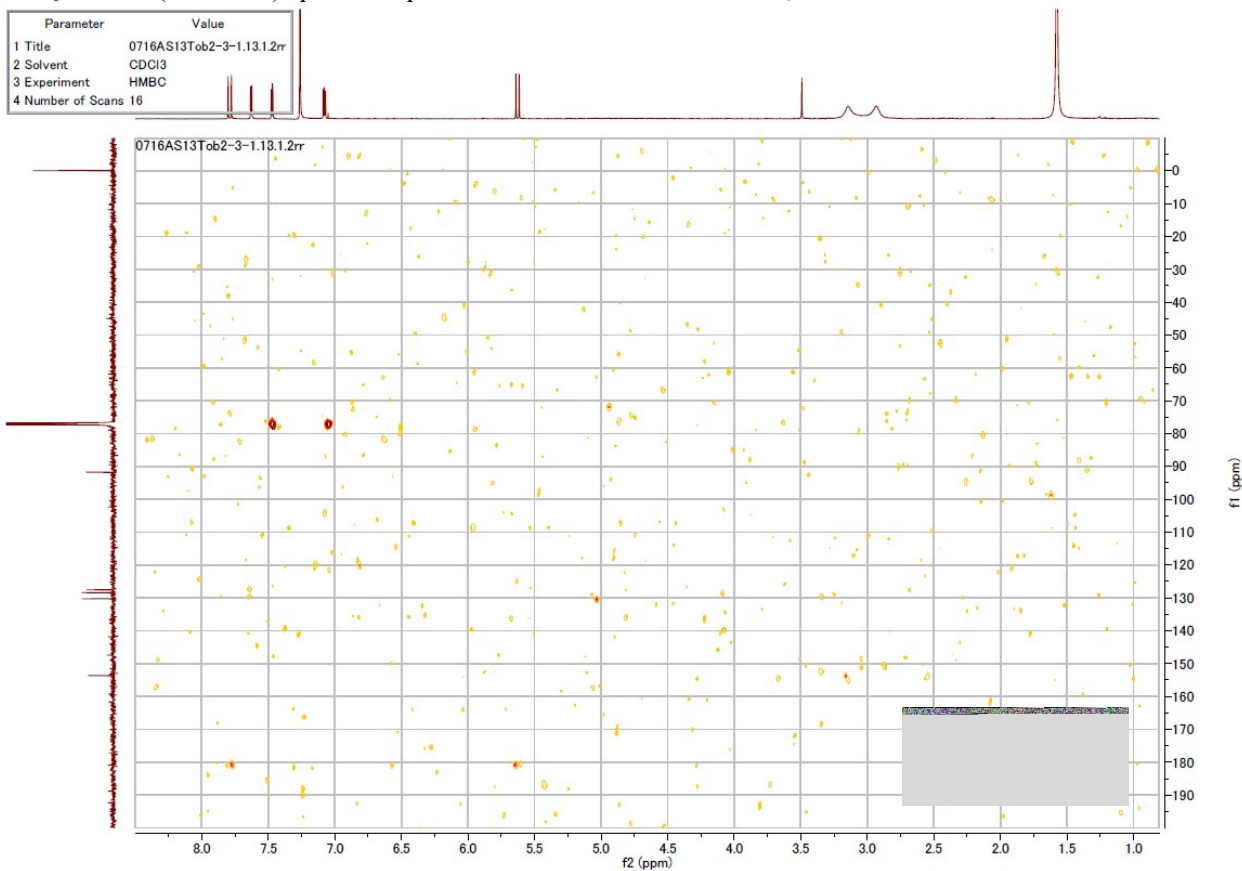
<sup>1</sup>H-NMR (500 MHz) spectroscopic data of 13. Measured in CDCl<sub>3</sub>.



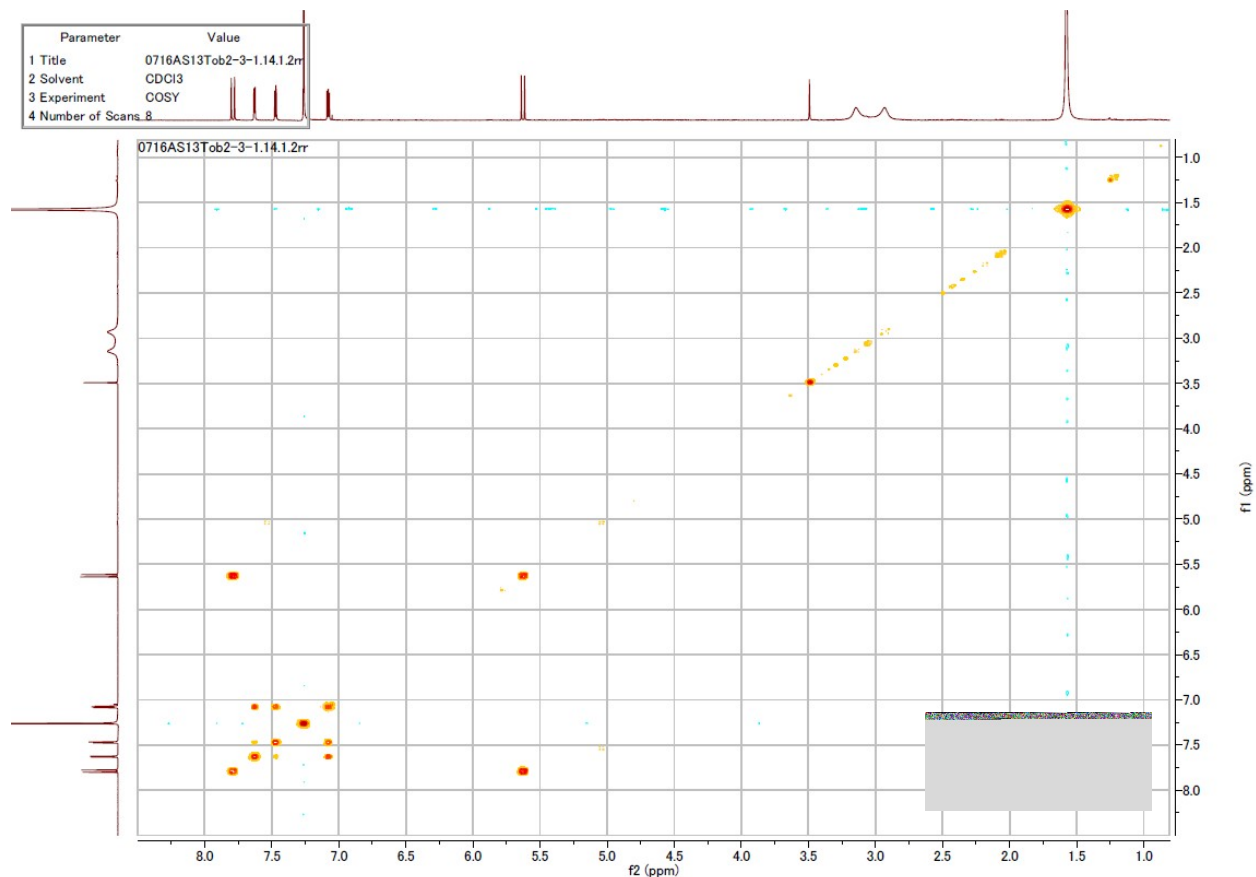
<sup>13</sup>C-NMR (125 MHz) spectroscopic data of 13. Measured in CDCl<sub>3</sub>.



HMQC NMR (500 MHz) spectroscopic data of **13**. Measured in CDCl<sub>3</sub>.

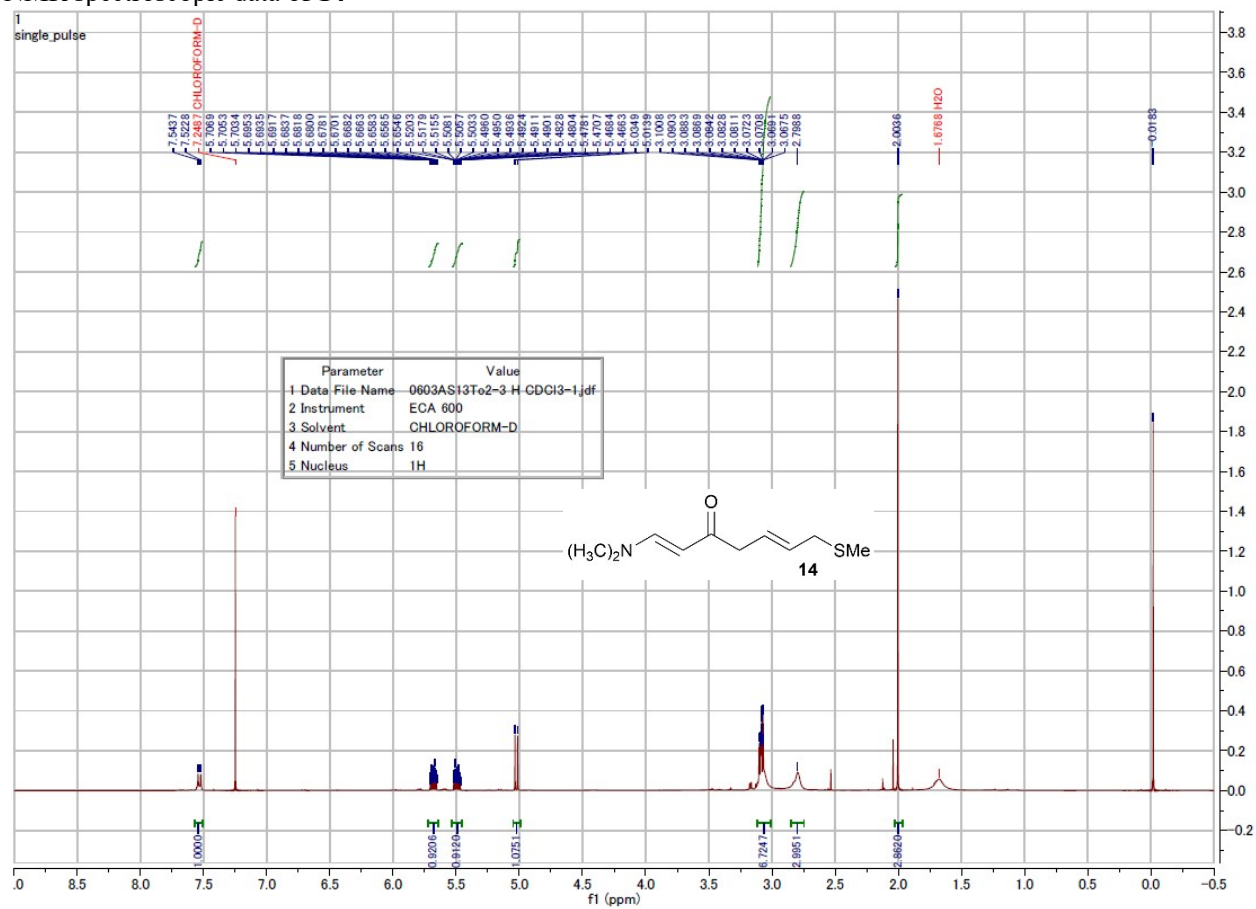


HMBC NMR (500 MHz) spectroscopic data of **13**. Measured in CDCl<sub>3</sub>.



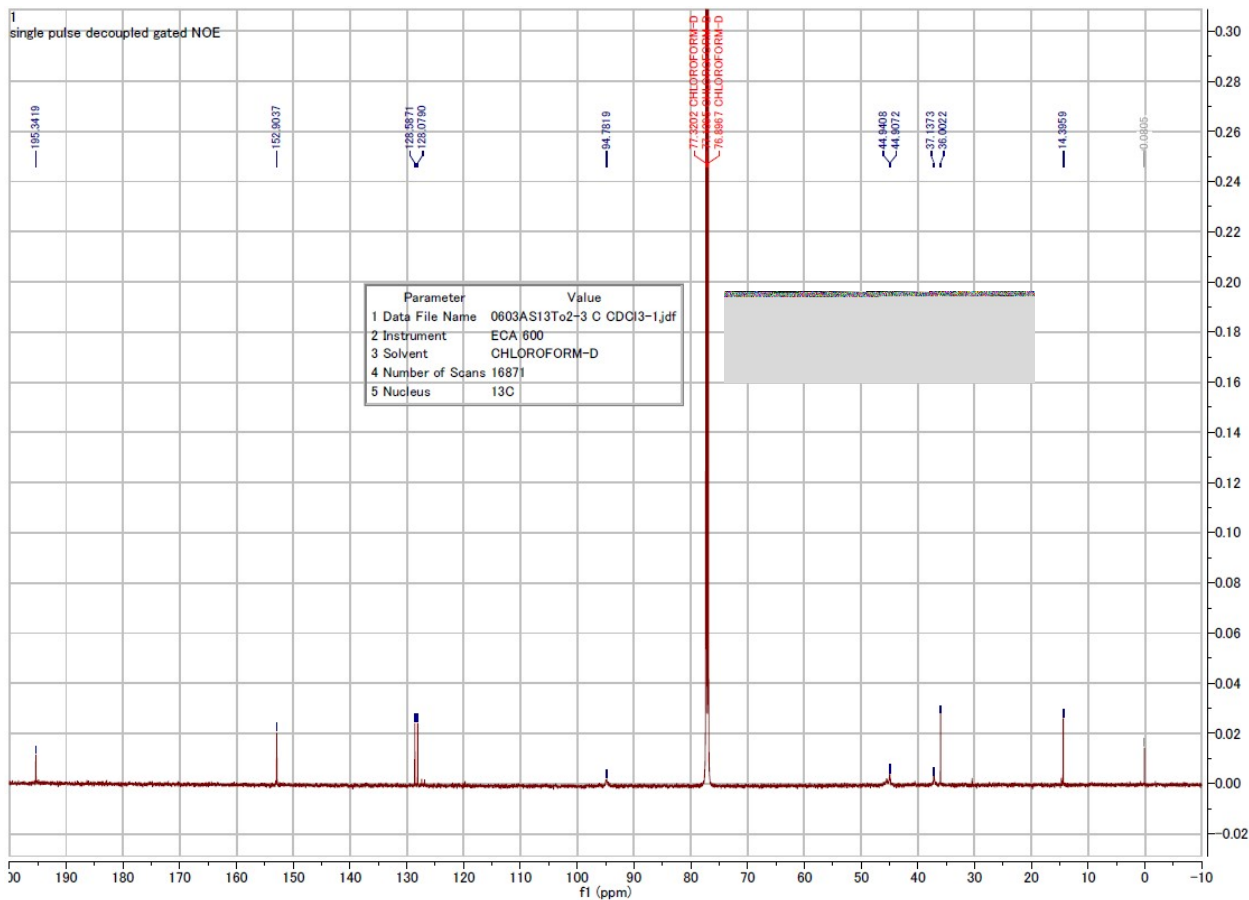
COSY NMR (500 MHz) spectroscopic data of **13**. Measured in CDCl<sub>3</sub>.

NMR spectroscopic data of **14**

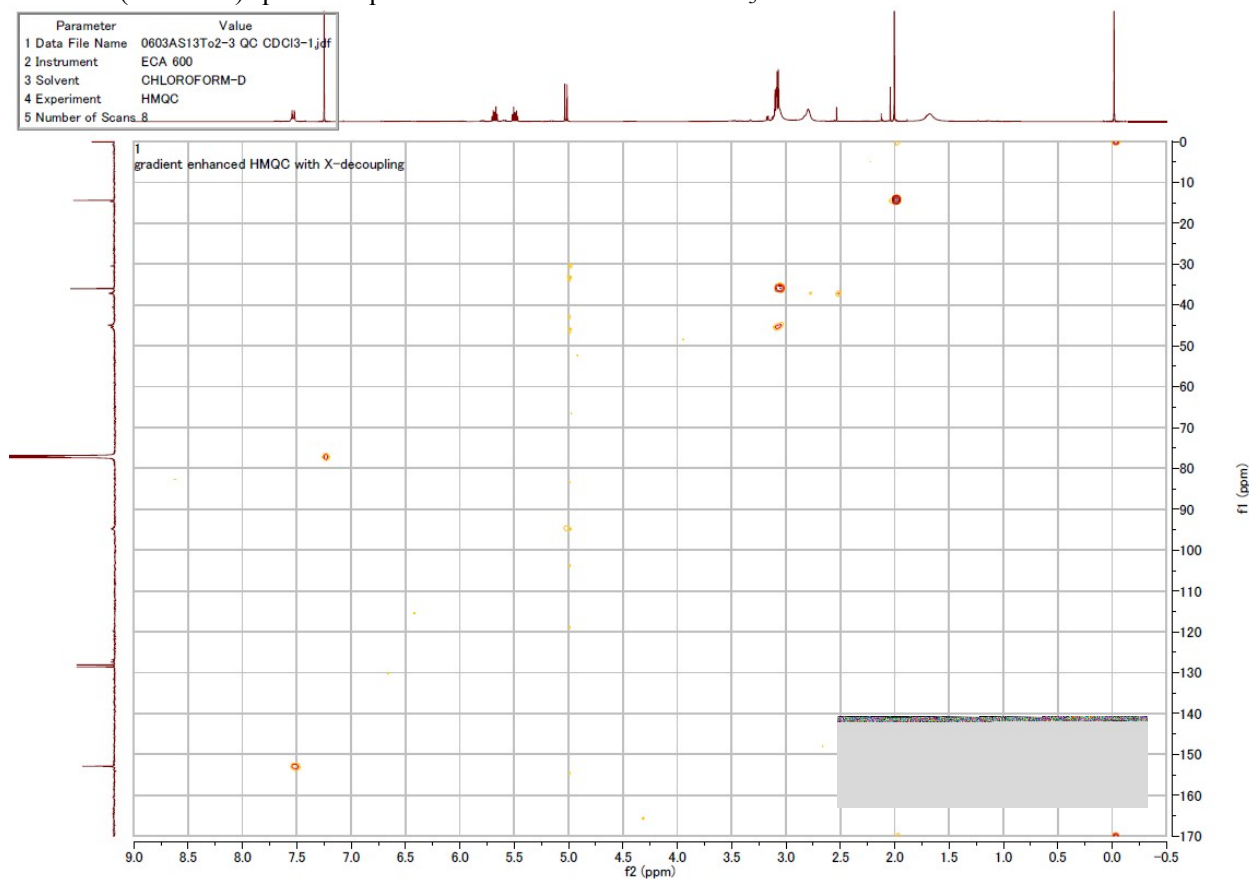


<sup>1</sup>H-NMR (600 MHz) spectroscopic data of **14**. Measured in CDCl<sub>3</sub>.



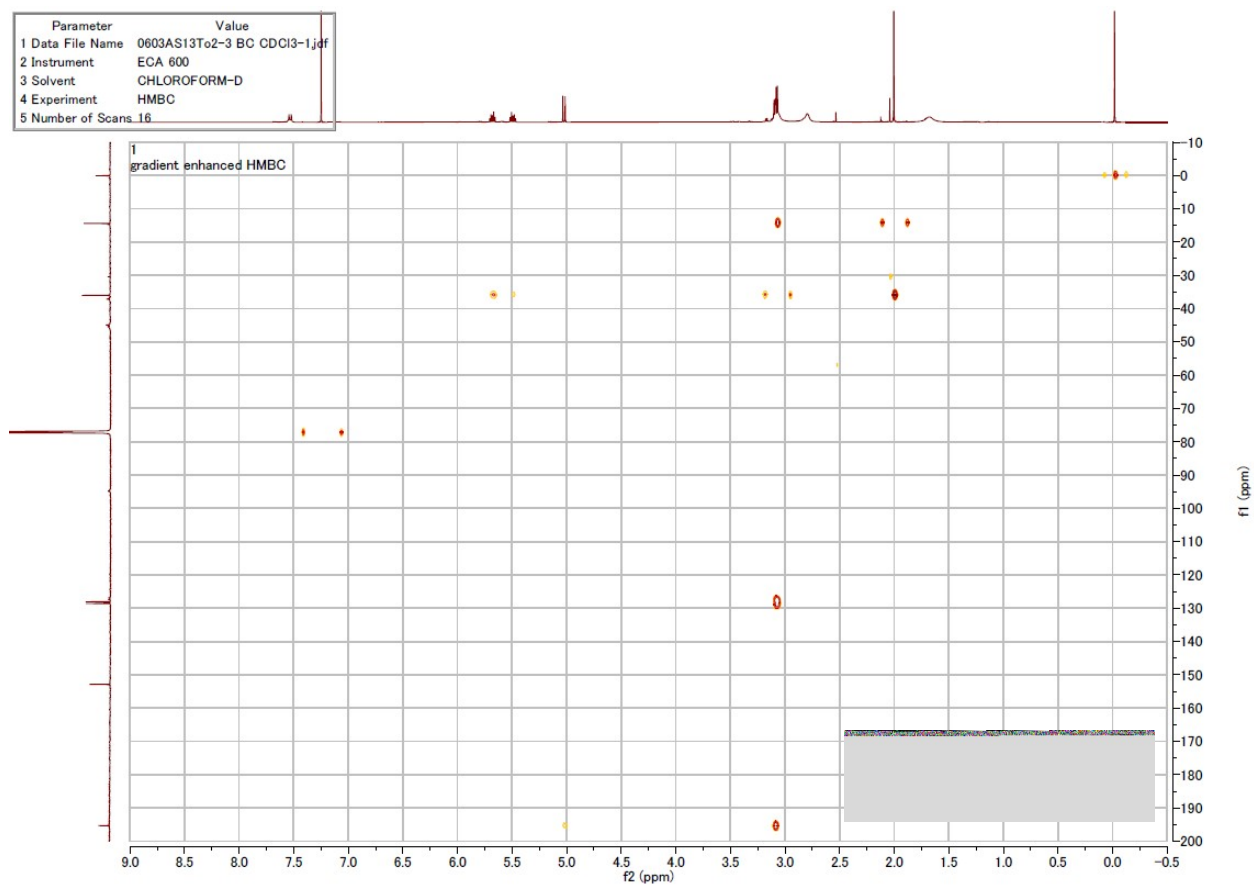


$^{13}\text{C}$ -NMR (150 MHz) spectroscopic data of **14**. Measured in  $\text{CDCl}_3$ .



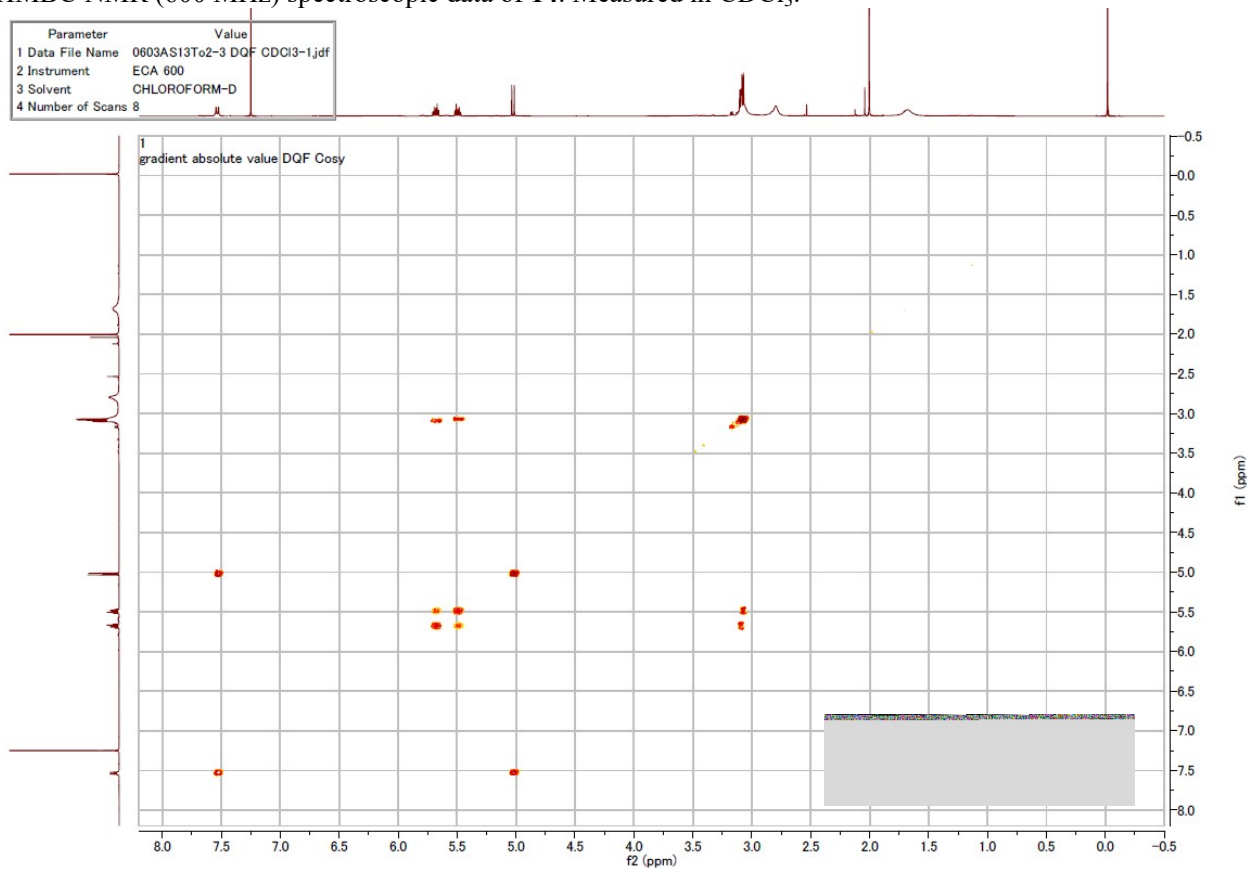
HMQC NMR (600 MHz) spectroscopic data of **14**. Measured in  $\text{CDCl}_3$ .

Parameter	Value
1 Data File Name	0603AS13To2-3 BC CDCl3-1.jdf
2 Instrument	ECA 600
3 Solvent	CHLOROFORM-D
4 Experiment	HMBC
5 Number of Scans	16



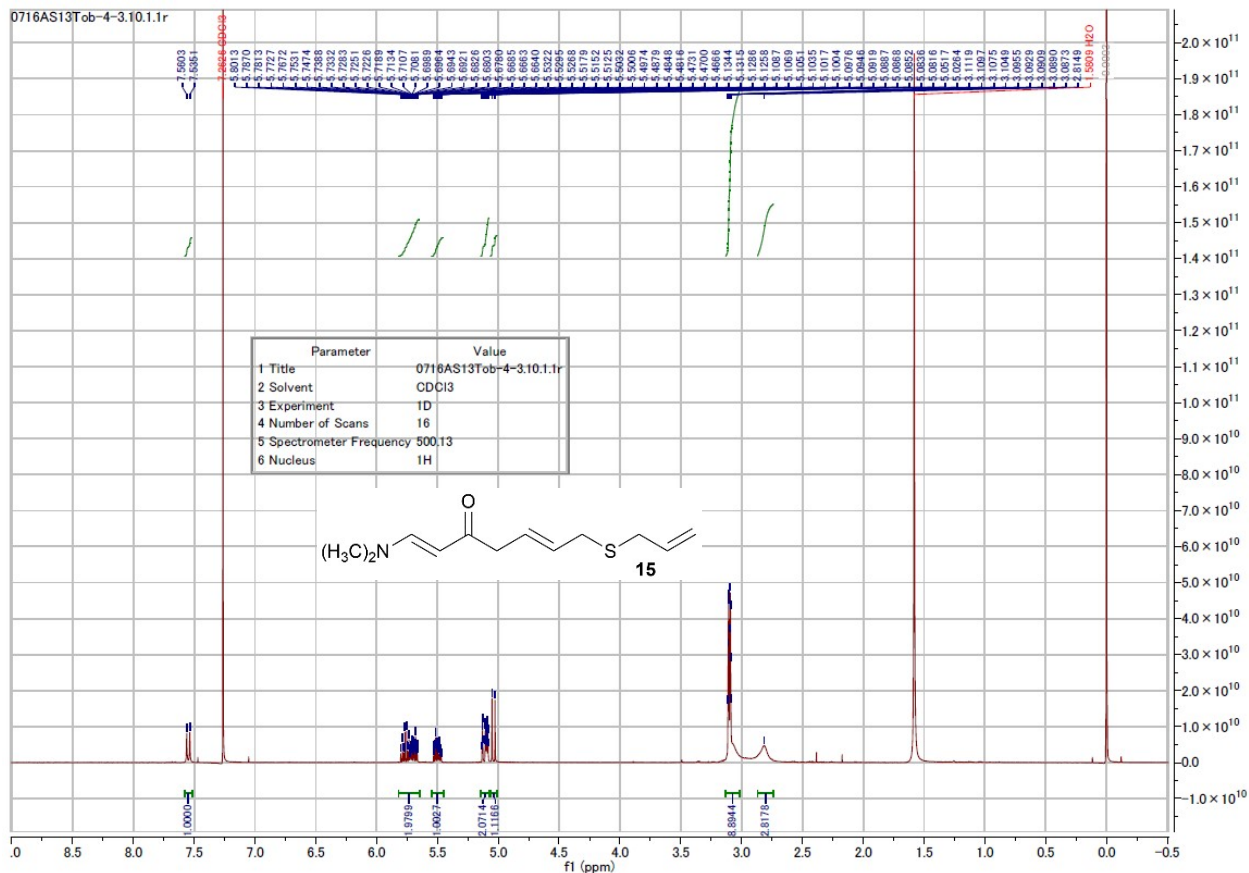
HMBC NMR (600 MHz) spectroscopic data of **14**. Measured in  $\text{CDCl}_3$ .

Parameter	Value
1 Data File Name	0603AS13To2-3 DQF CDCl3-1.jdf
2 Instrument	ECA 600
3 Solvent	CHLOROFORM-D
4 Number of Scans	8

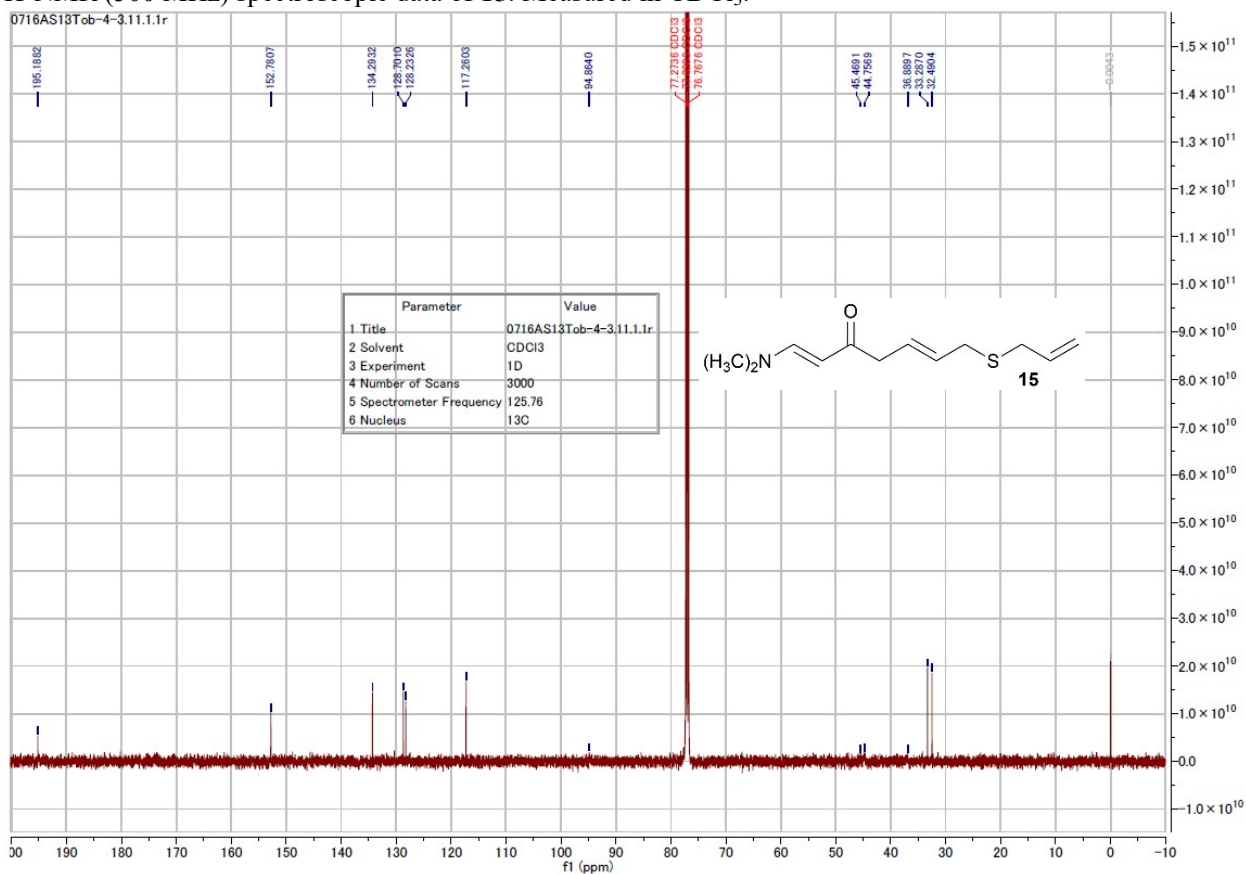


COSY NMR (600 MHz) spectroscopic data of **14**. Measured in  $\text{CDCl}_3$ .

# NMR spectroscopic data of 15

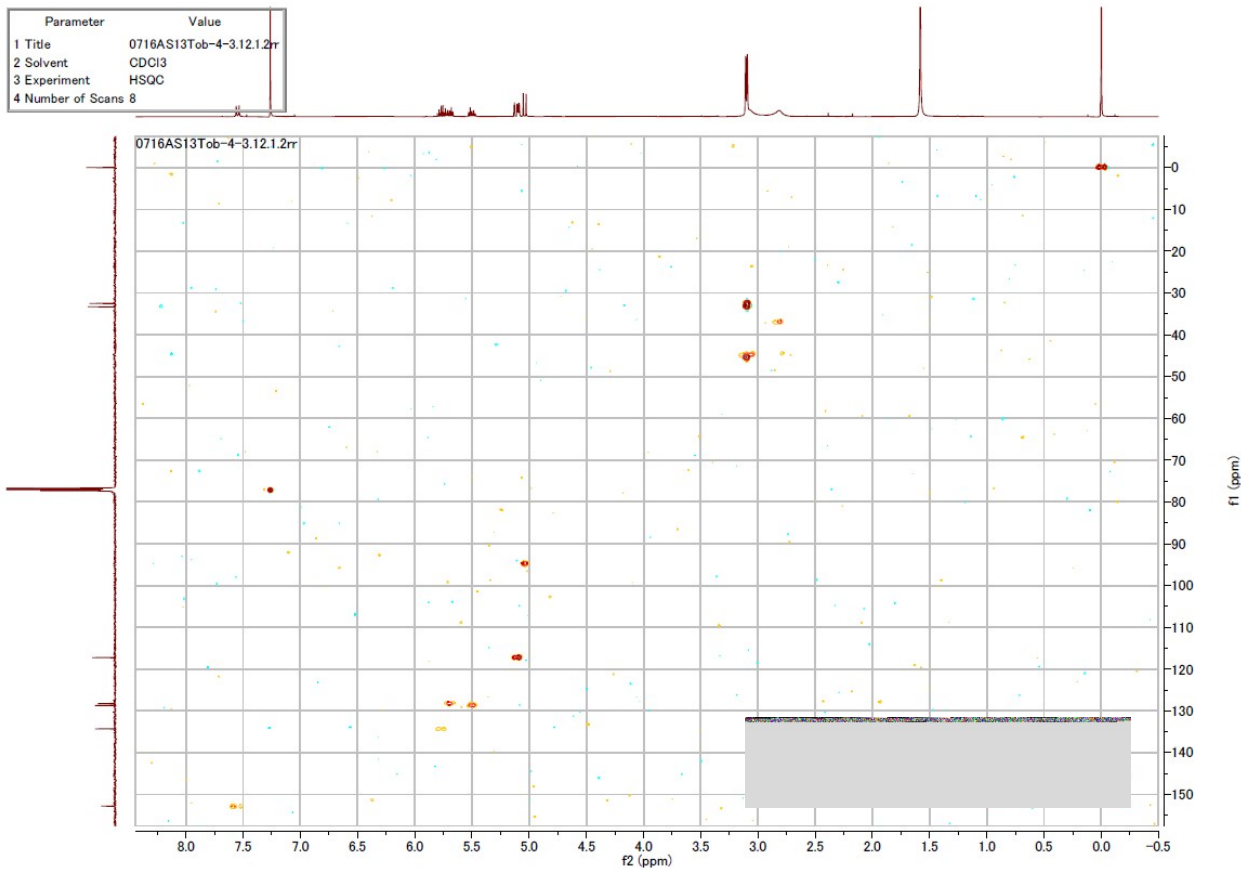


<sup>1</sup>H-NMR (500 MHz) spectroscopic data of 15. Measured in CDCl<sub>3</sub>.

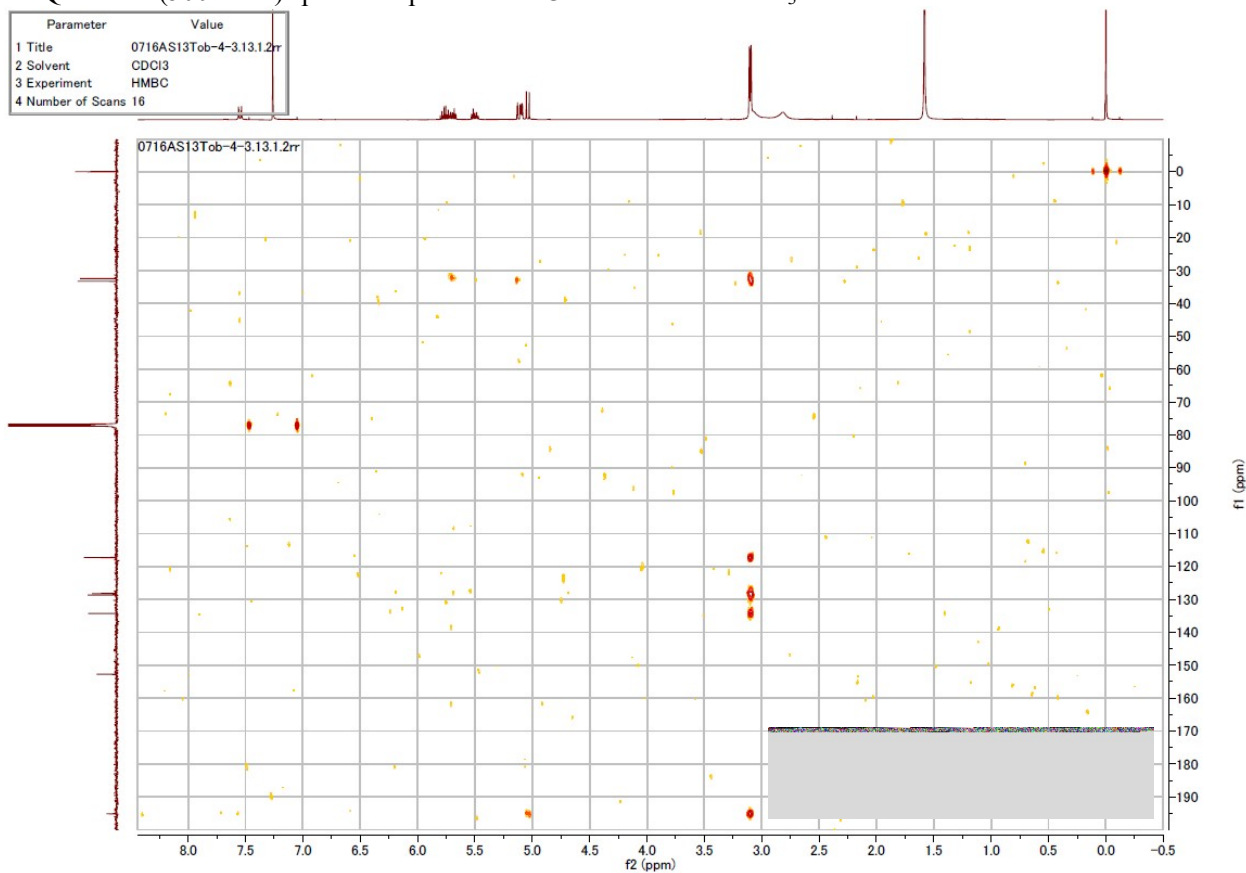


<sup>13</sup>C-NMR (125 MHz) spectroscopic data of 15. Measured in CDCl<sub>3</sub>.

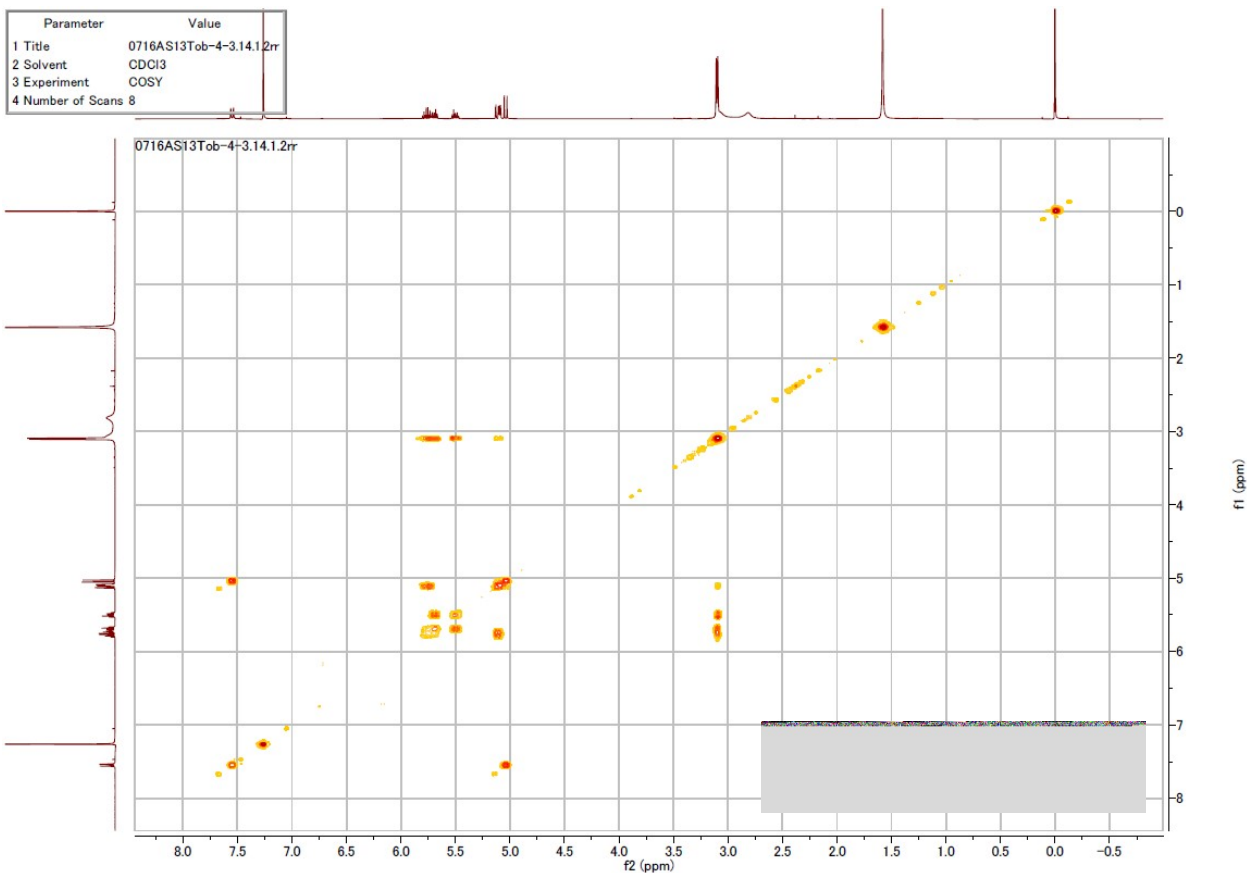




HMQC NMR (500 MHz) spectroscopic data of **15**. Measured in CDCl<sub>3</sub>.

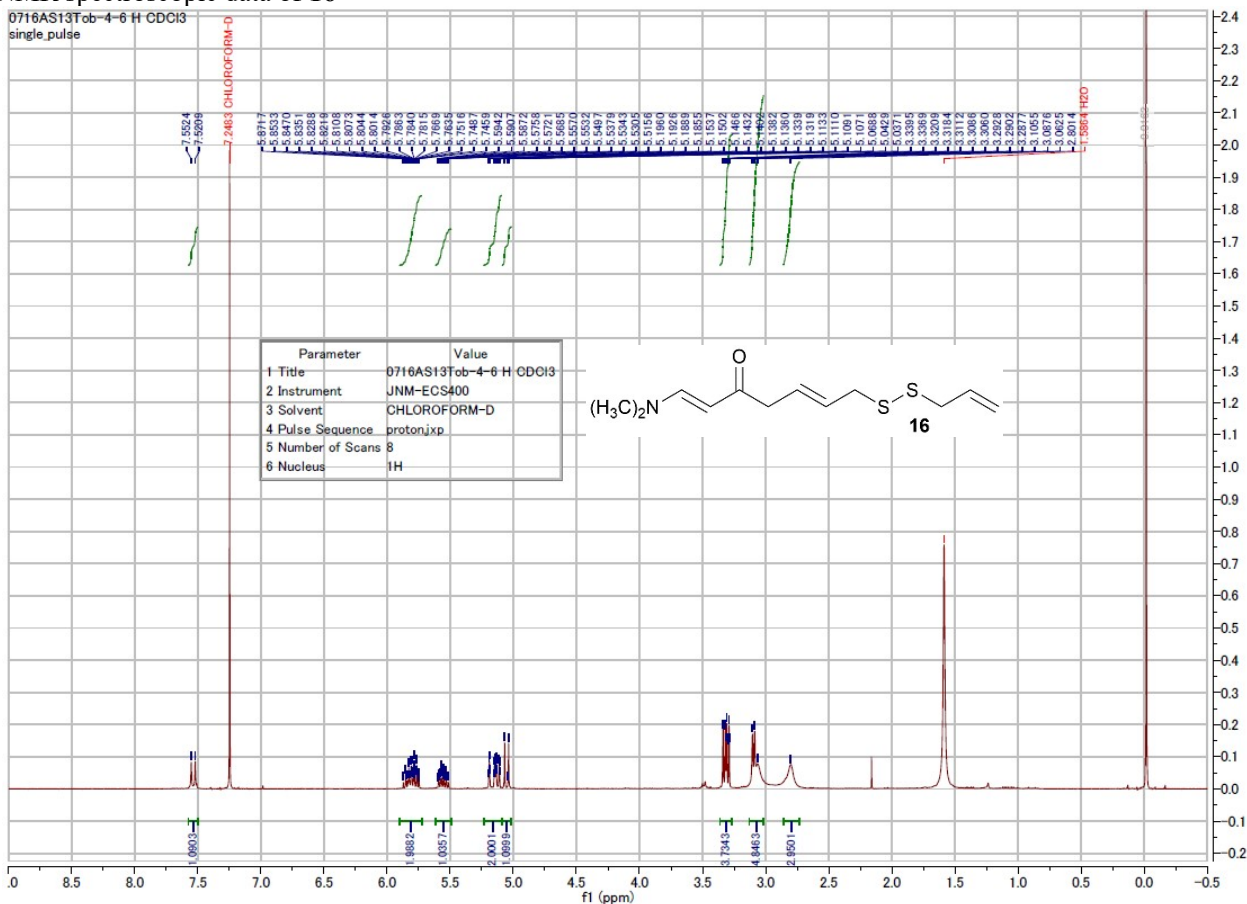


HMBC NMR (500 MHz) spectroscopic data of **15**. Measured in CDCl<sub>3</sub>.

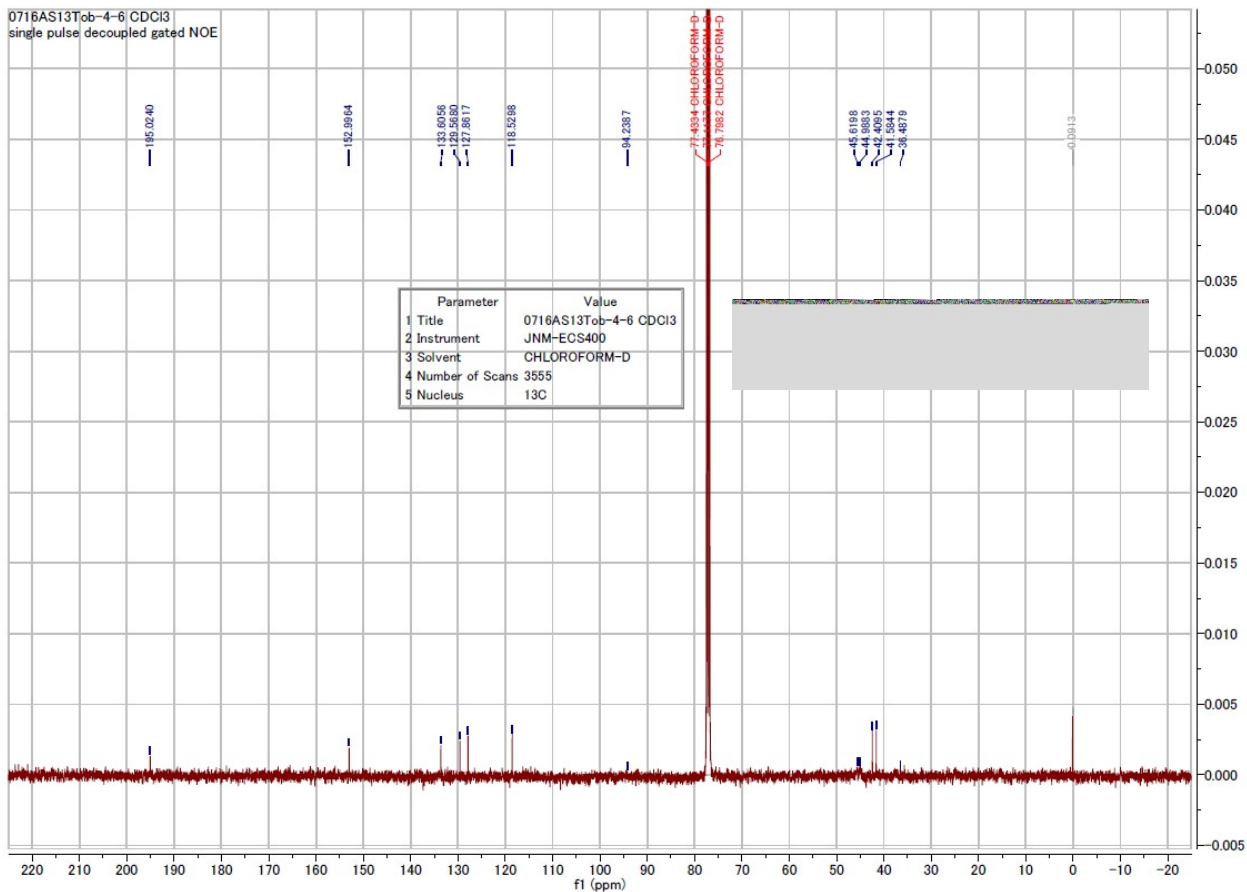


COSY NMR (500 MHz) spectroscopic data of **15**. Measured in CDCl<sub>3</sub>.

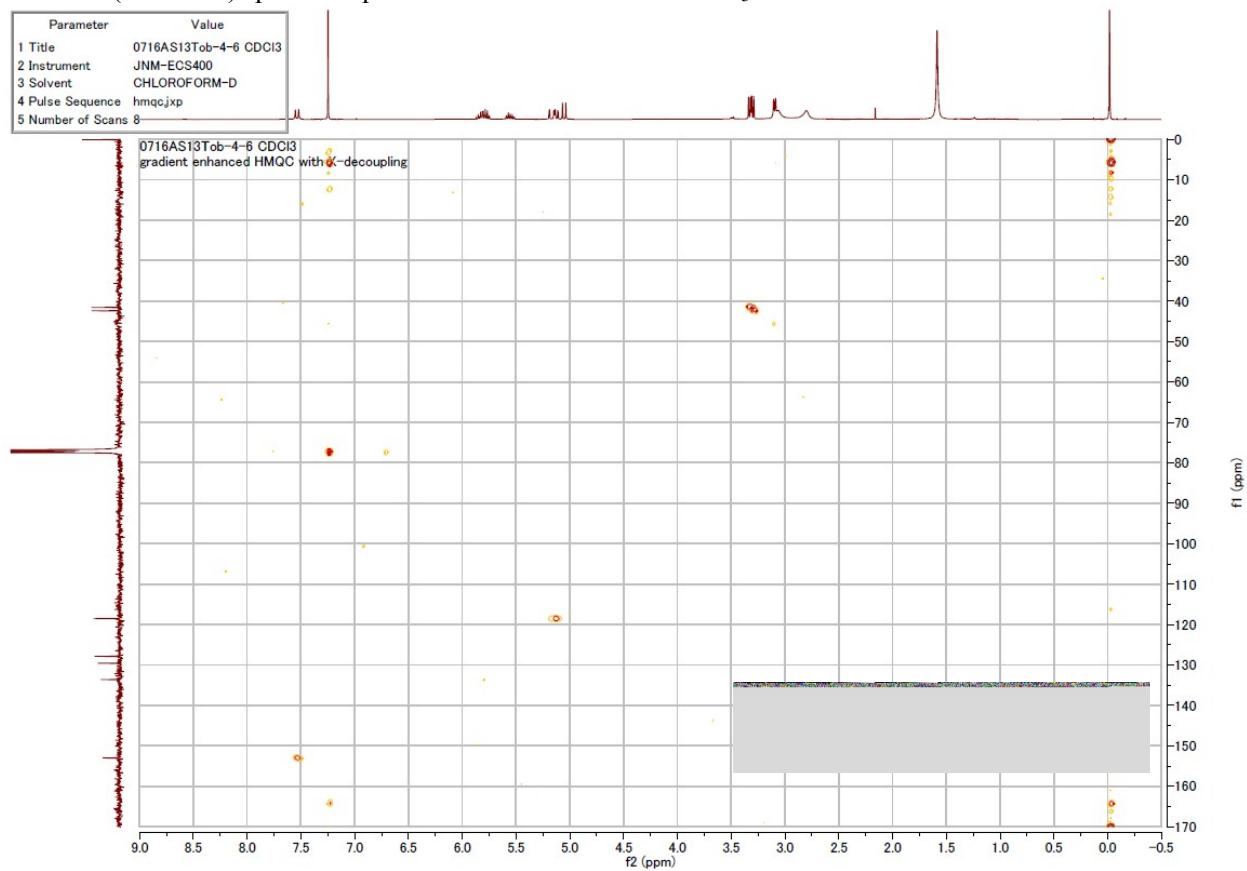
NMR spectroscopic data of **16**



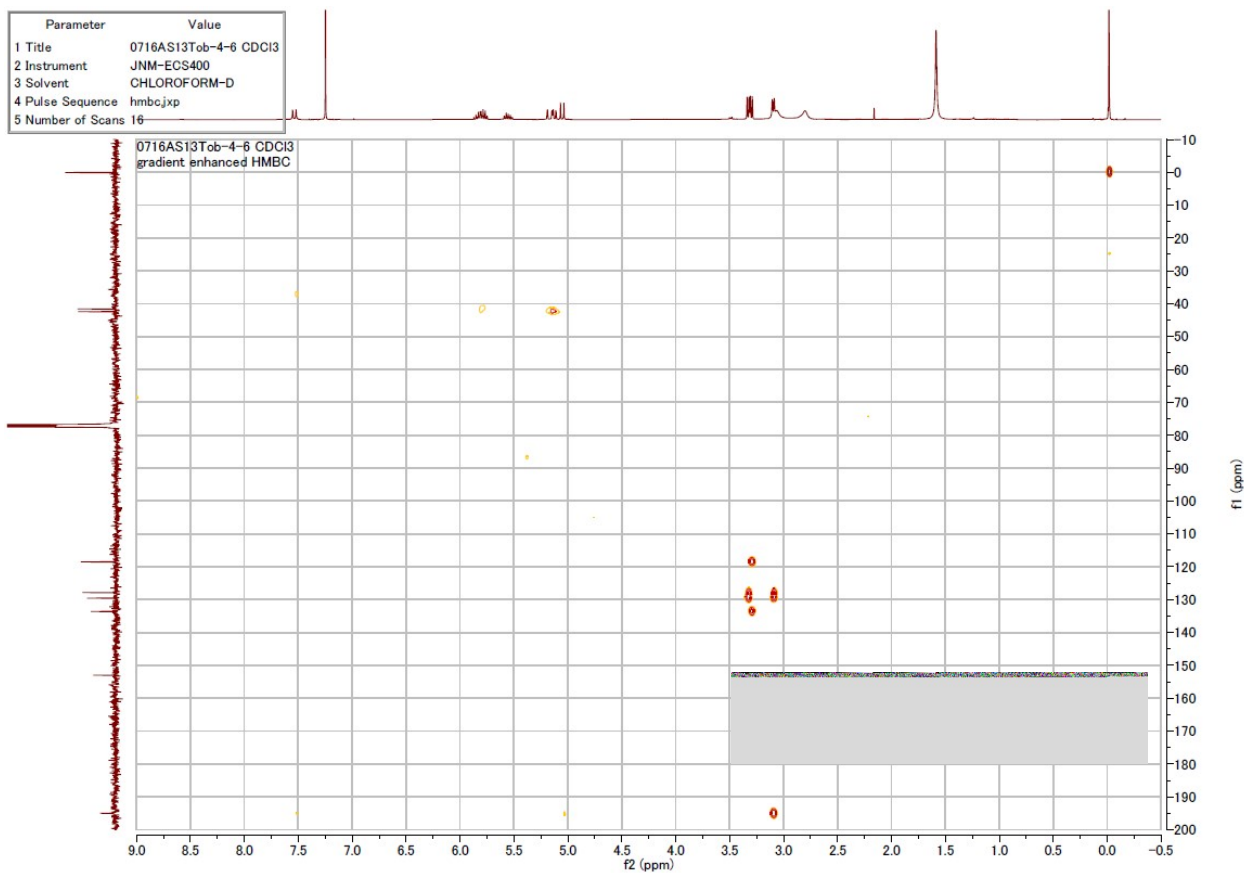
<sup>1</sup>H-NMR (400 MHz) spectroscopic data of **16**. Measured in CDCl<sub>3</sub>.



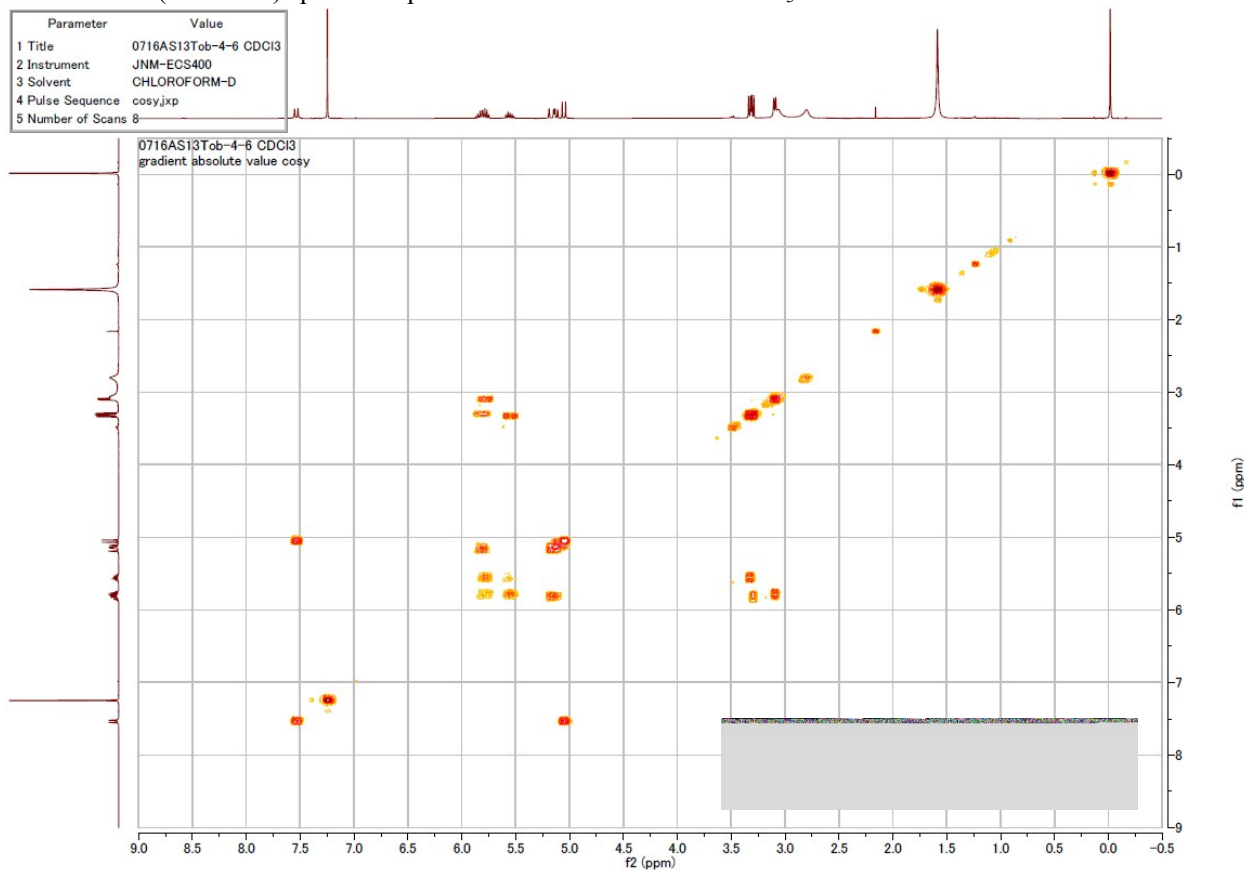
<sup>13</sup>C-NMR (100 MHz) spectroscopic data of **16**. Measured in CDCl<sub>3</sub>.



HMQC NMR (400 MHz) spectroscopic data of **16**. Measured in CDCl<sub>3</sub>.

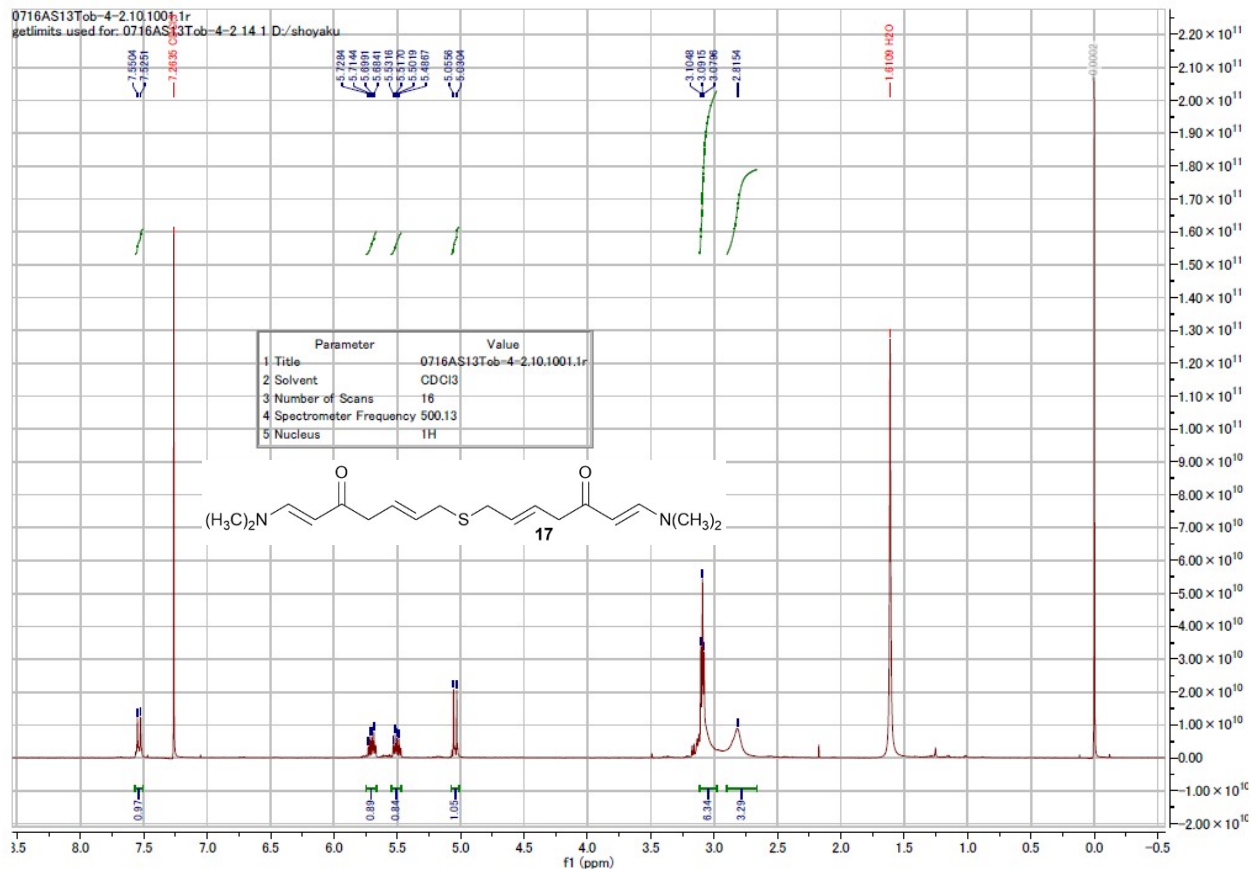


HMBC NMR (400 MHz) spectroscopic data of **16**. Measured in CDCl<sub>3</sub>.

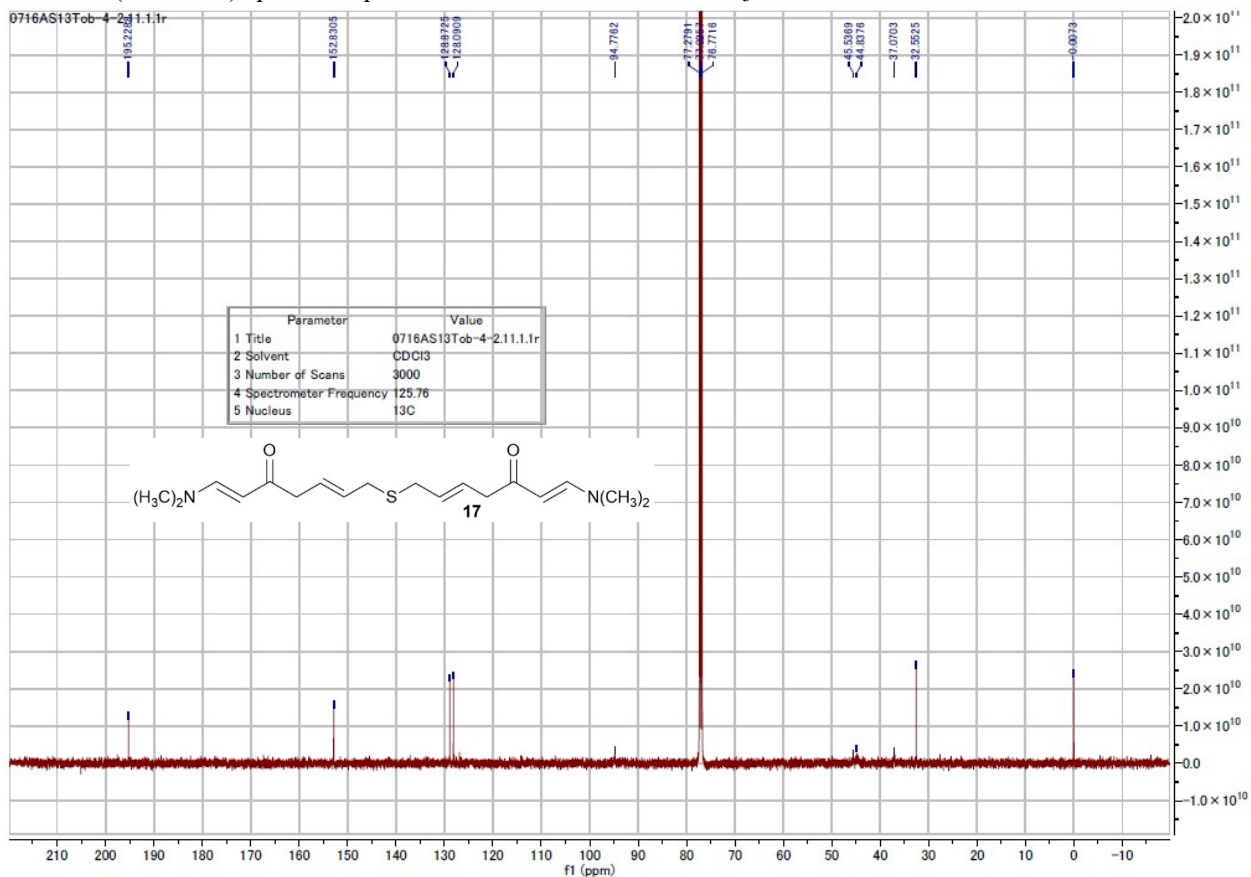


COSY NMR (400 MHz) spectroscopic data of **16**. Measured in CDCl<sub>3</sub>.

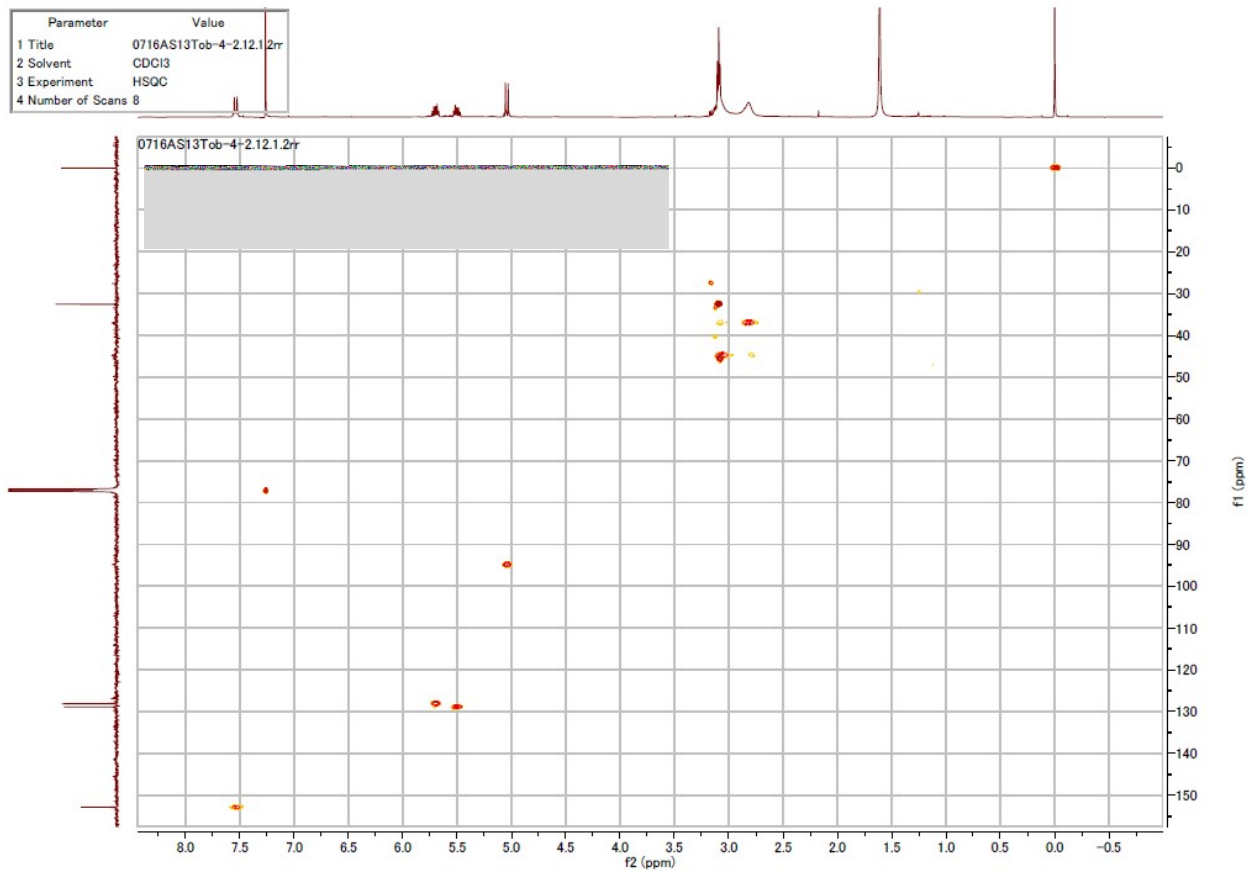
# NMR spectroscopic data of 17



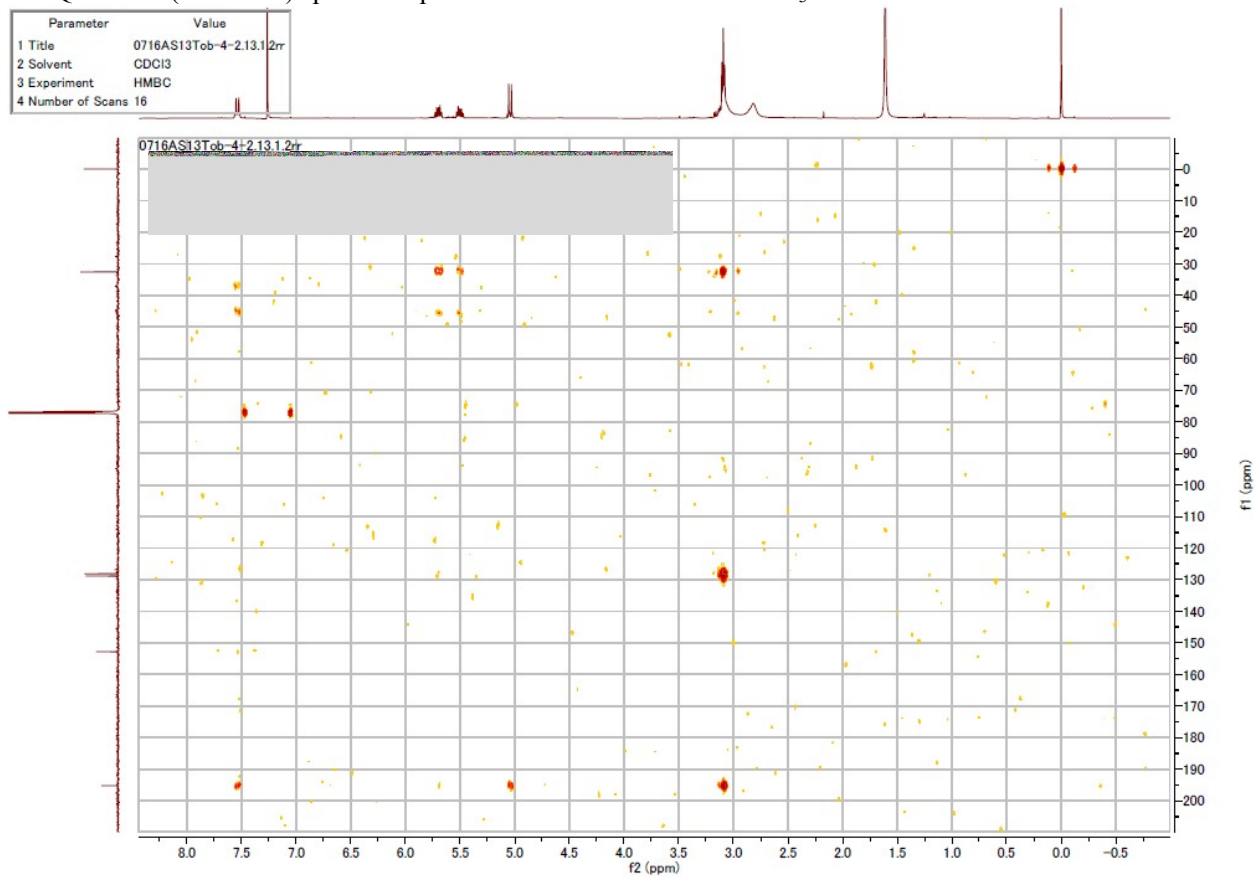
<sup>1</sup>H-NMR (500 MHz) spectroscopic data of 17. Measured in CDCl<sub>3</sub>.



<sup>13</sup>C-NMR (125 MHz) spectroscopic data of 17. Measured in CDCl<sub>3</sub>.

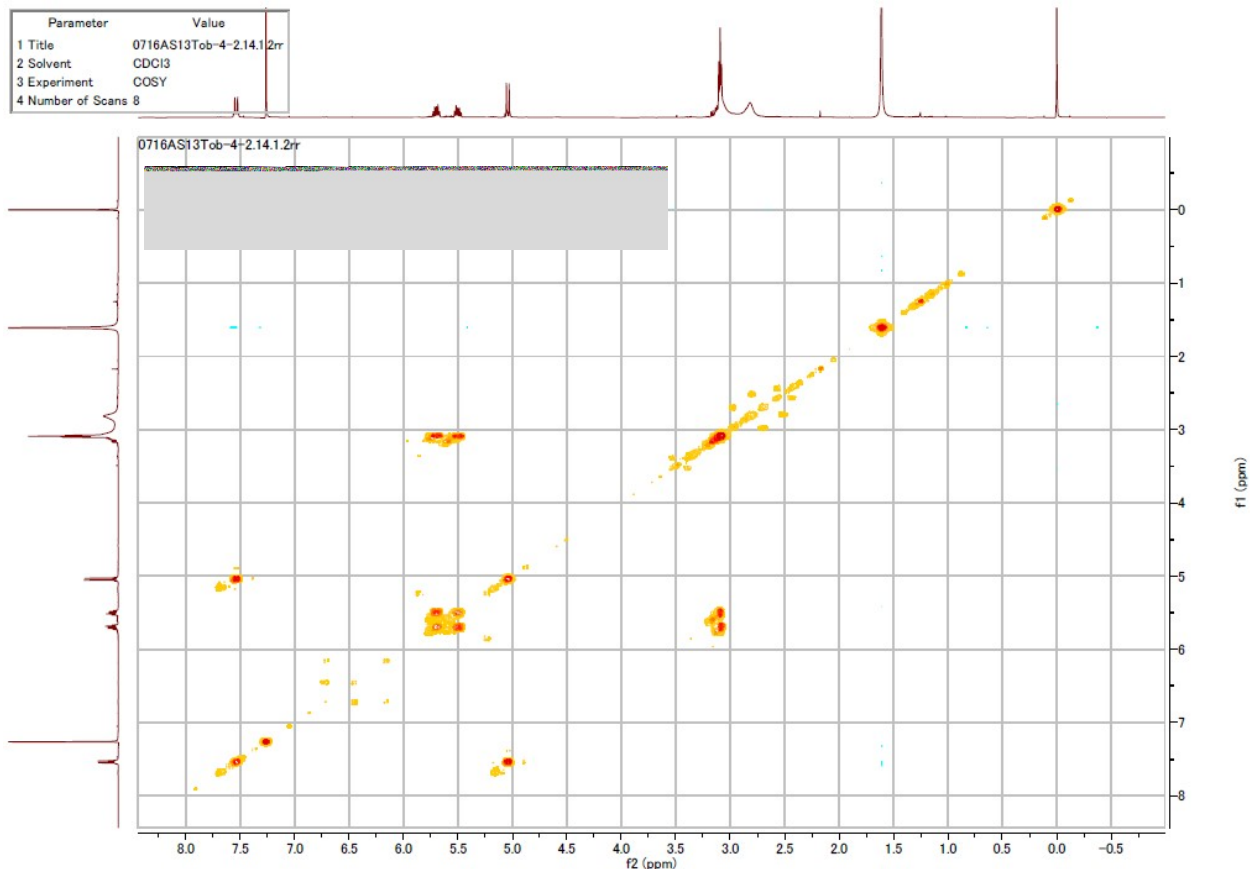


HMQC NMR (500 MHz) spectroscopic data of **17**. Measured in CDCl<sub>3</sub>.



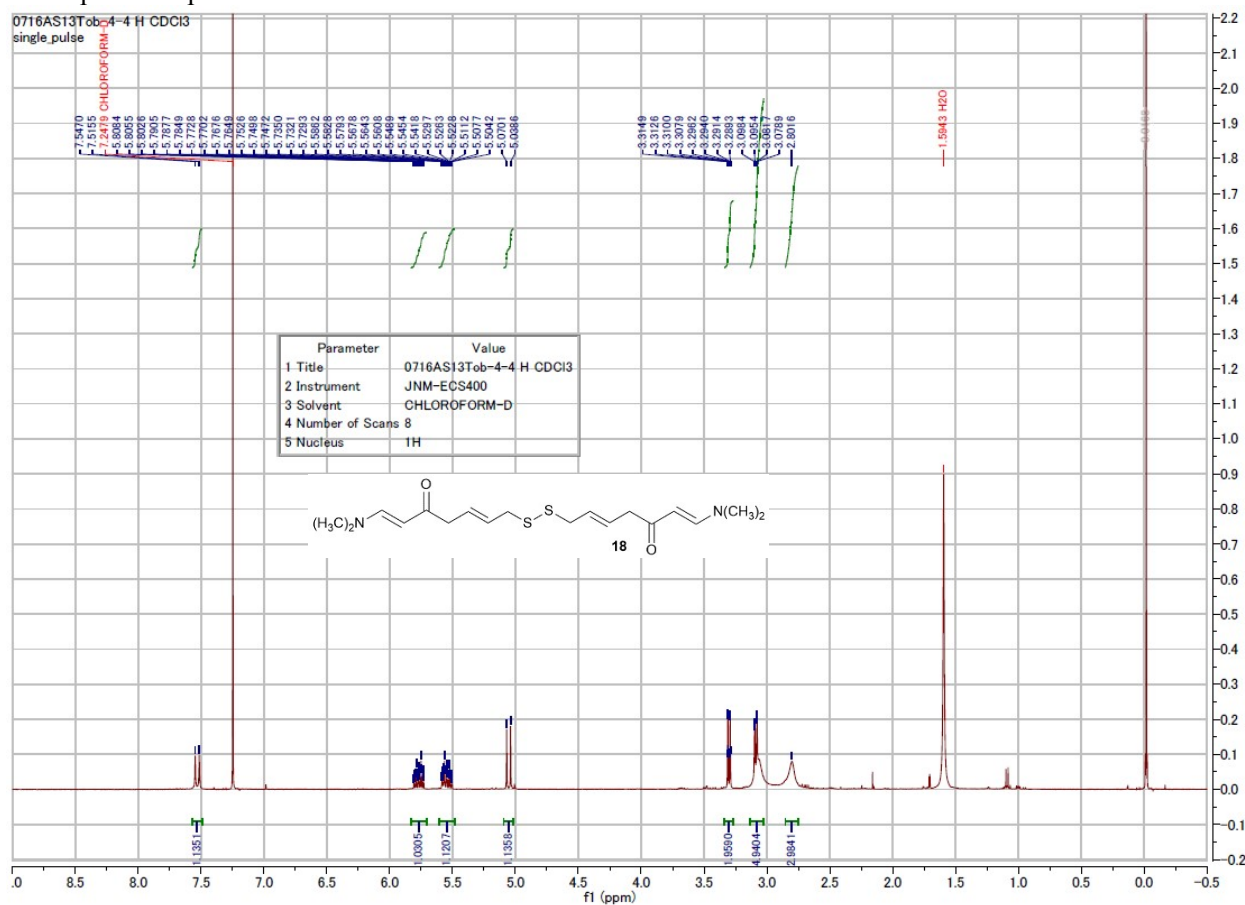
HMBC NMR (500 MHz) spectroscopic data of **17**. Measured in CDCl<sub>3</sub>.



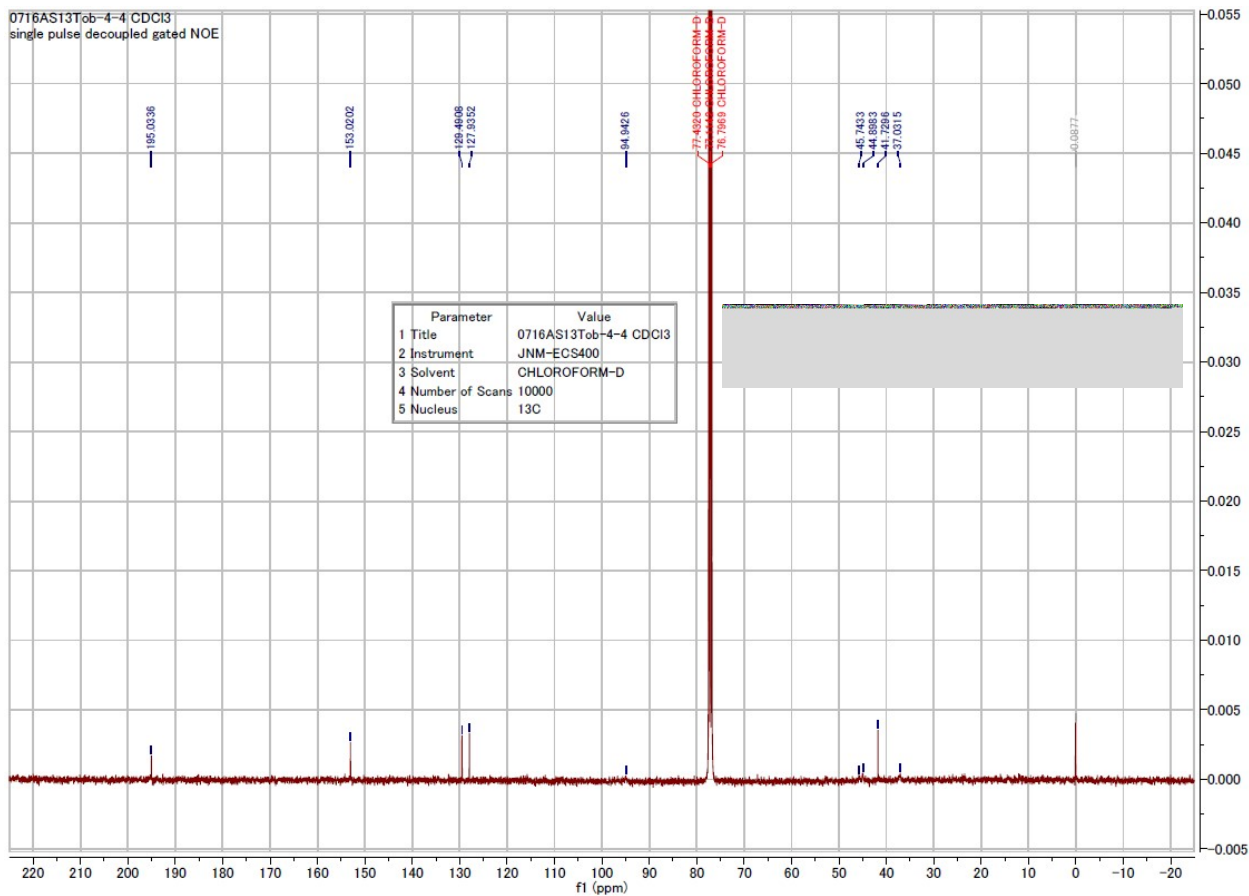


COSY NMR (500 MHz) spectroscopic data of **17**. Measured in CDCl<sub>3</sub>.

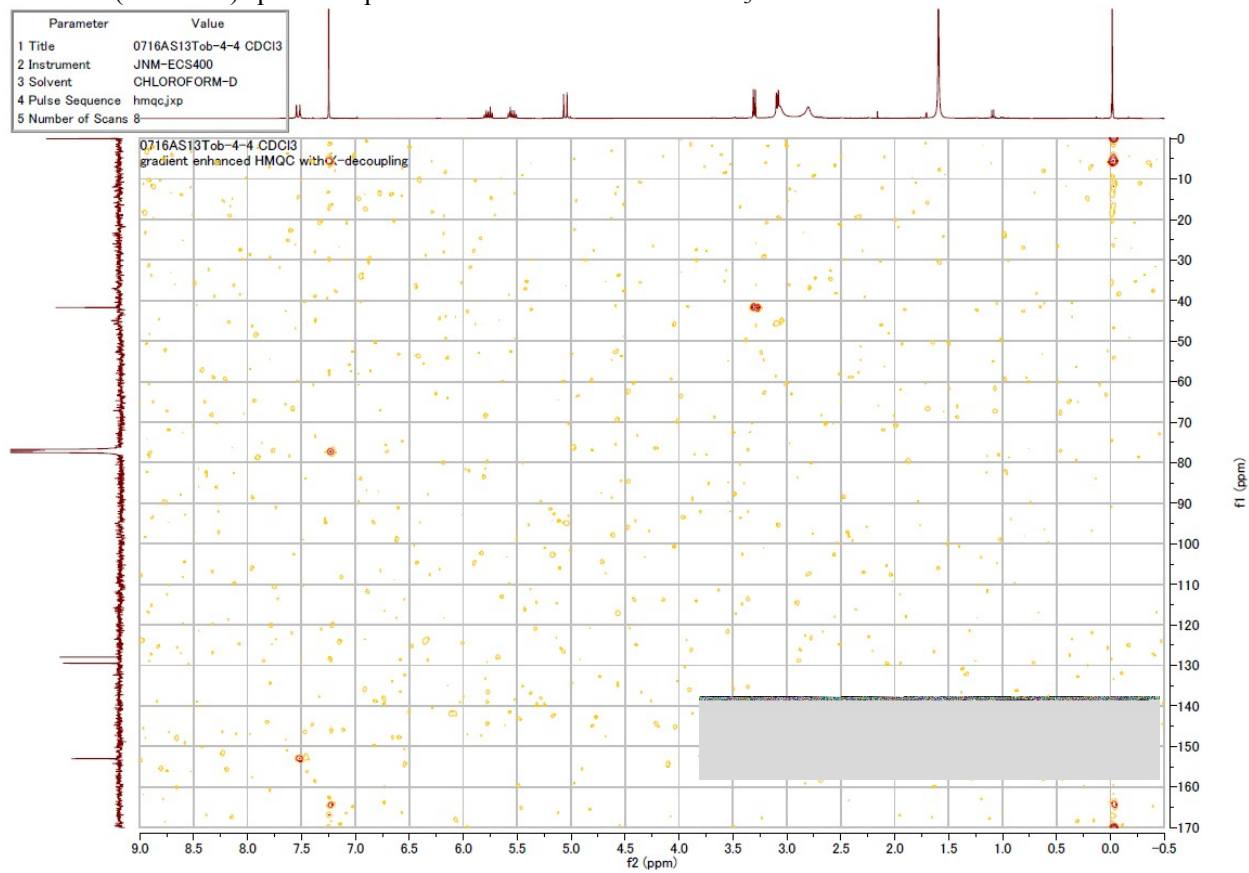
### NMR spectroscopic data of **18**



<sup>1</sup>H-NMR (400 MHz) spectroscopic data of **18**. Measured in CDCl<sub>3</sub>.

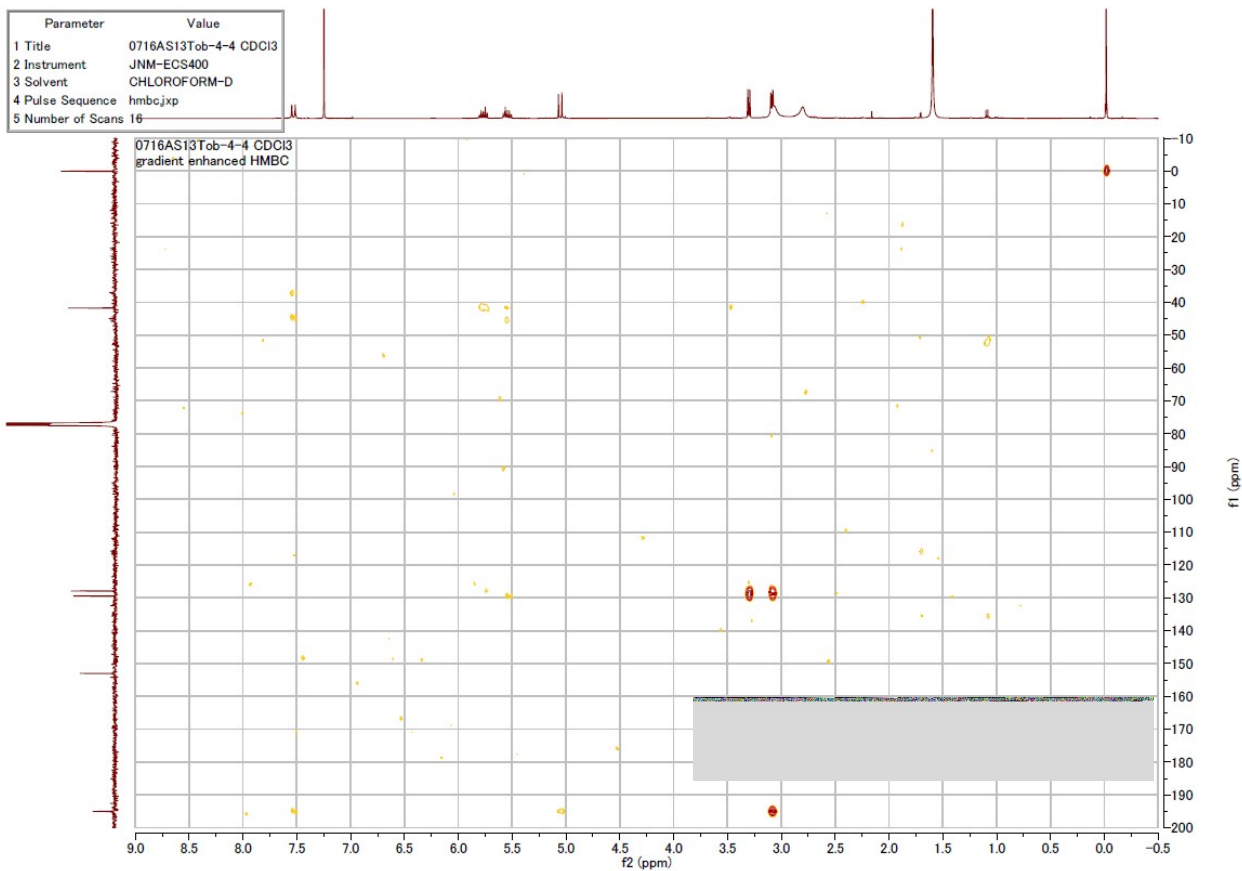


<sup>13</sup>C-NMR (100 MHz) spectroscopic data of **18**. Measured in CDCl<sub>3</sub>.

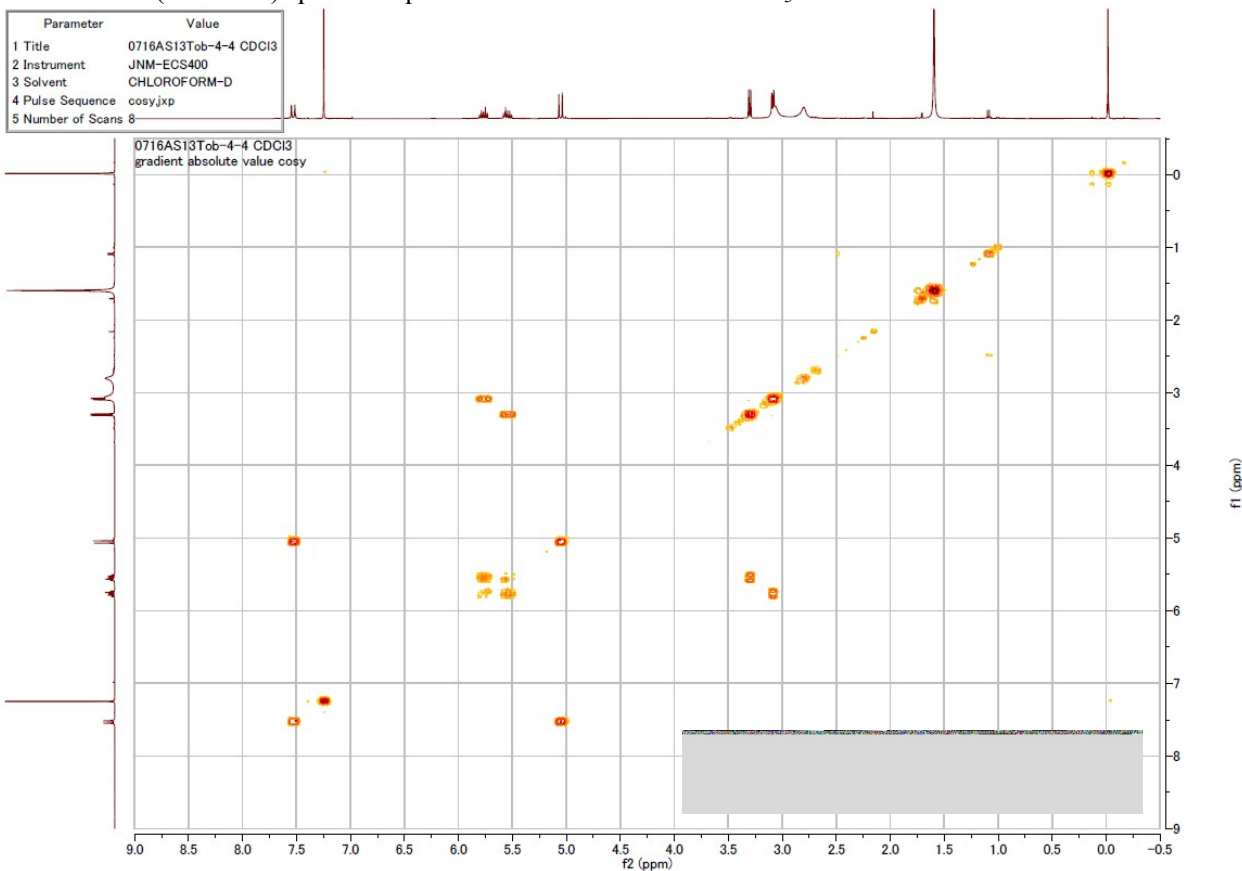


HMQC NMR (400 MHz) spectroscopic data of **18**. Measured in CDCl<sub>3</sub>.



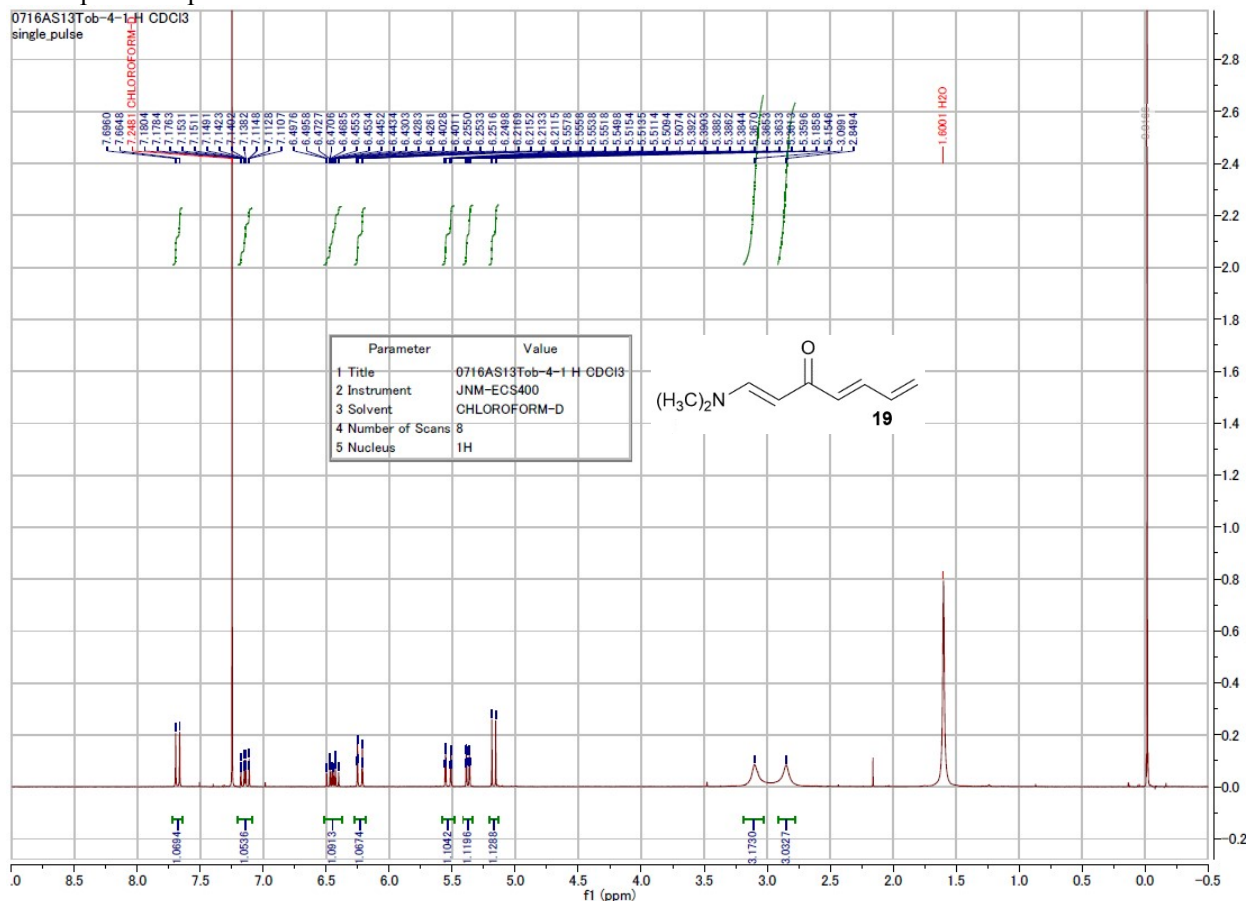


HMBC NMR (400 MHz) spectroscopic data of **18**. Measured in  $\text{CDCl}_3$ .

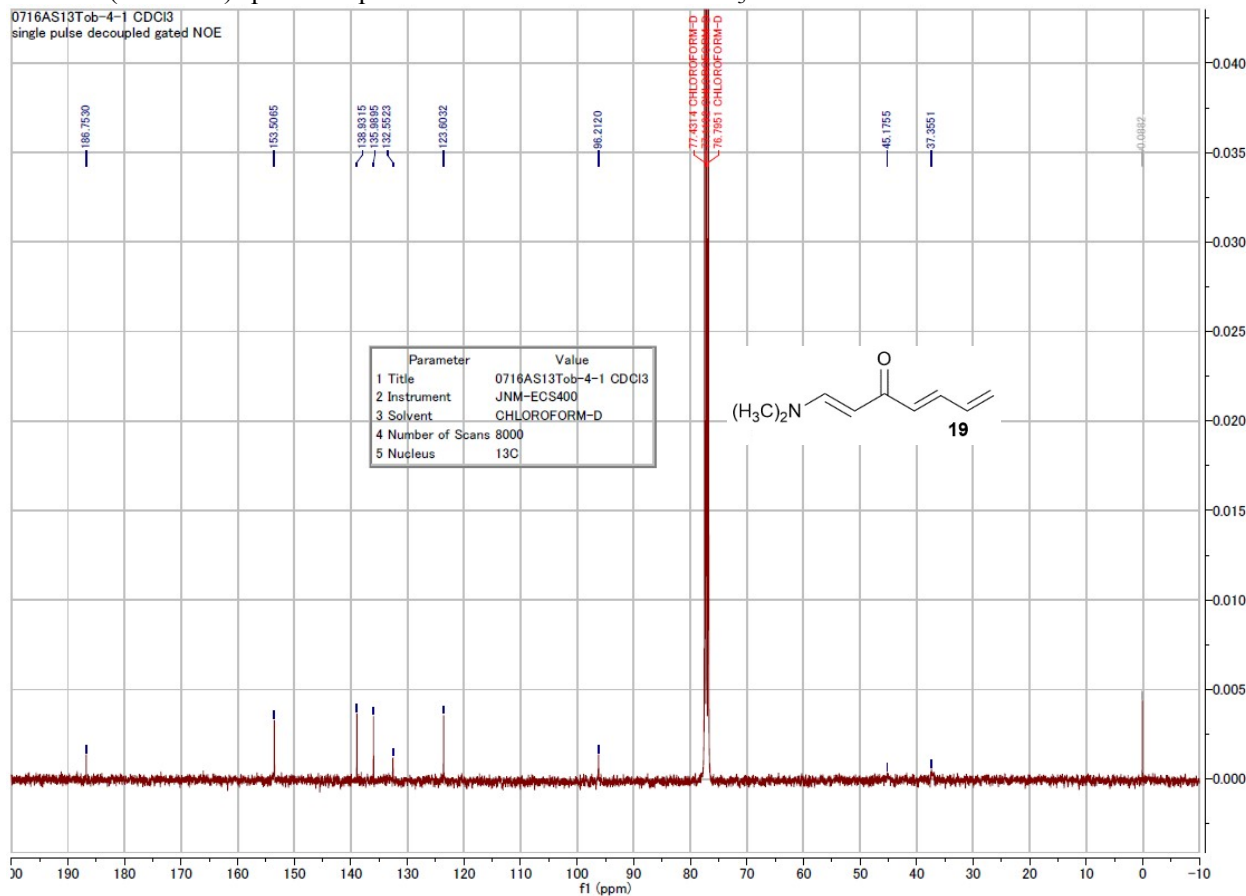


COSY NMR (400 MHz) spectroscopic data of **18**. Measured in  $\text{CDCl}_3$ .

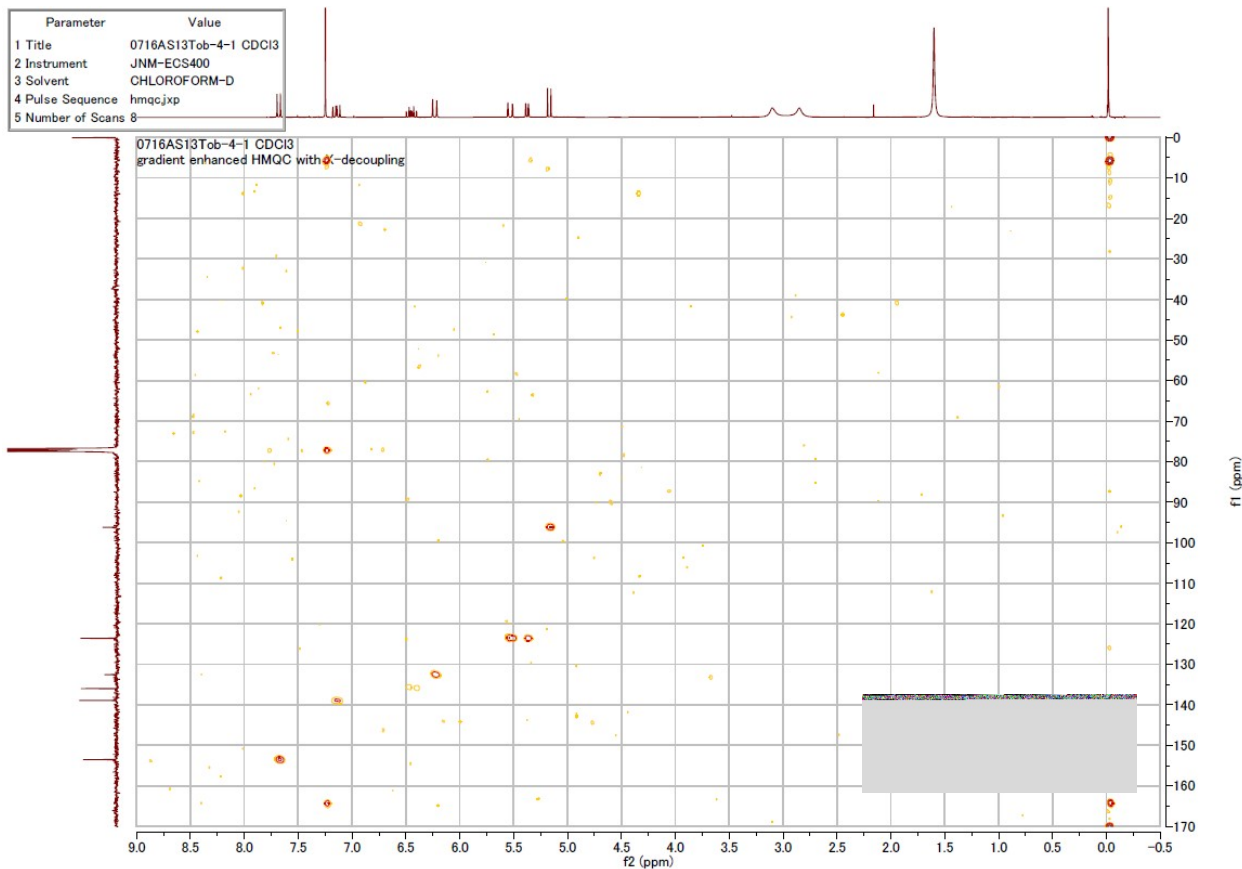
# NMR spectroscopic data of 19



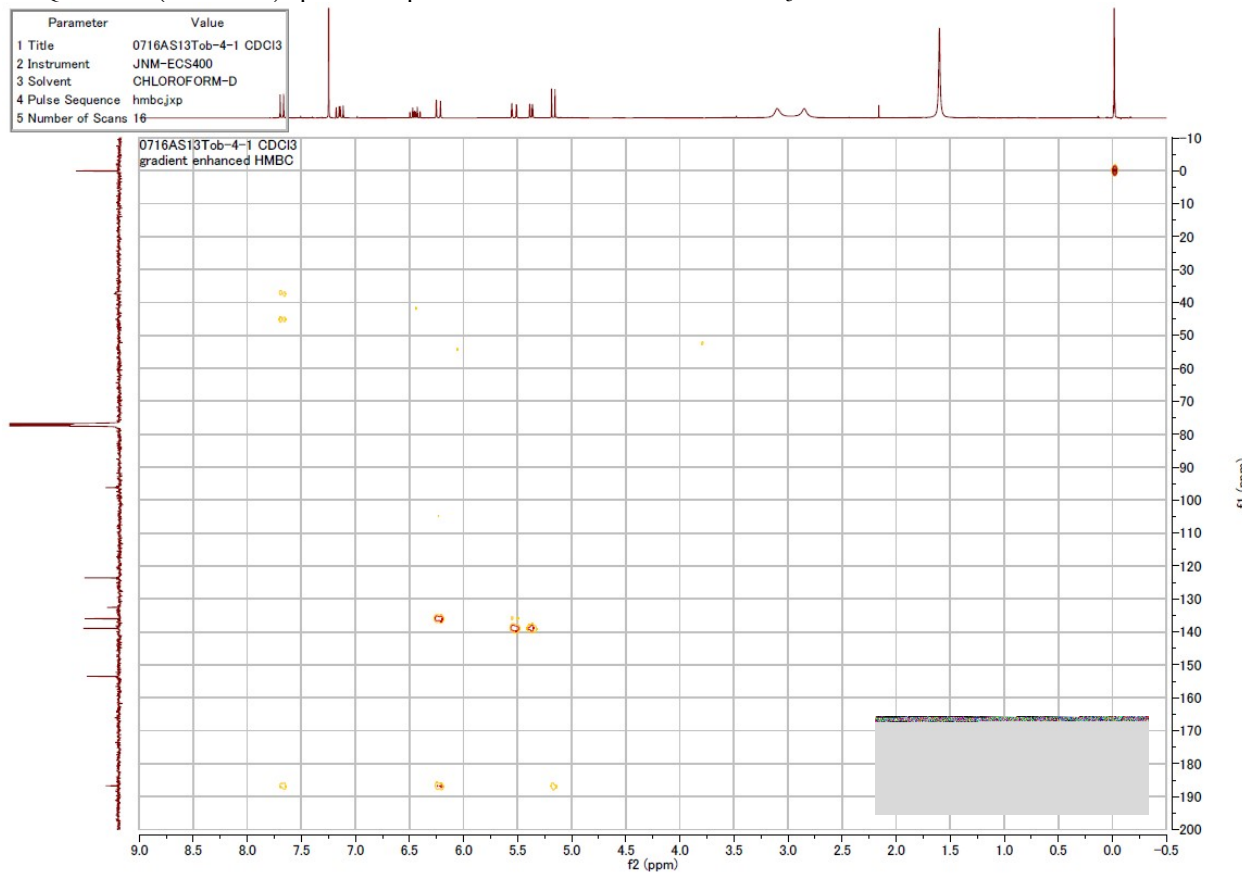
<sup>1</sup>H-NMR (400 MHz) spectroscopic data of 19. Measured in CDCl<sub>3</sub>.



<sup>13</sup>C-NMR (100 MHz) spectroscopic data of 19. Measured in CDCl<sub>3</sub>.

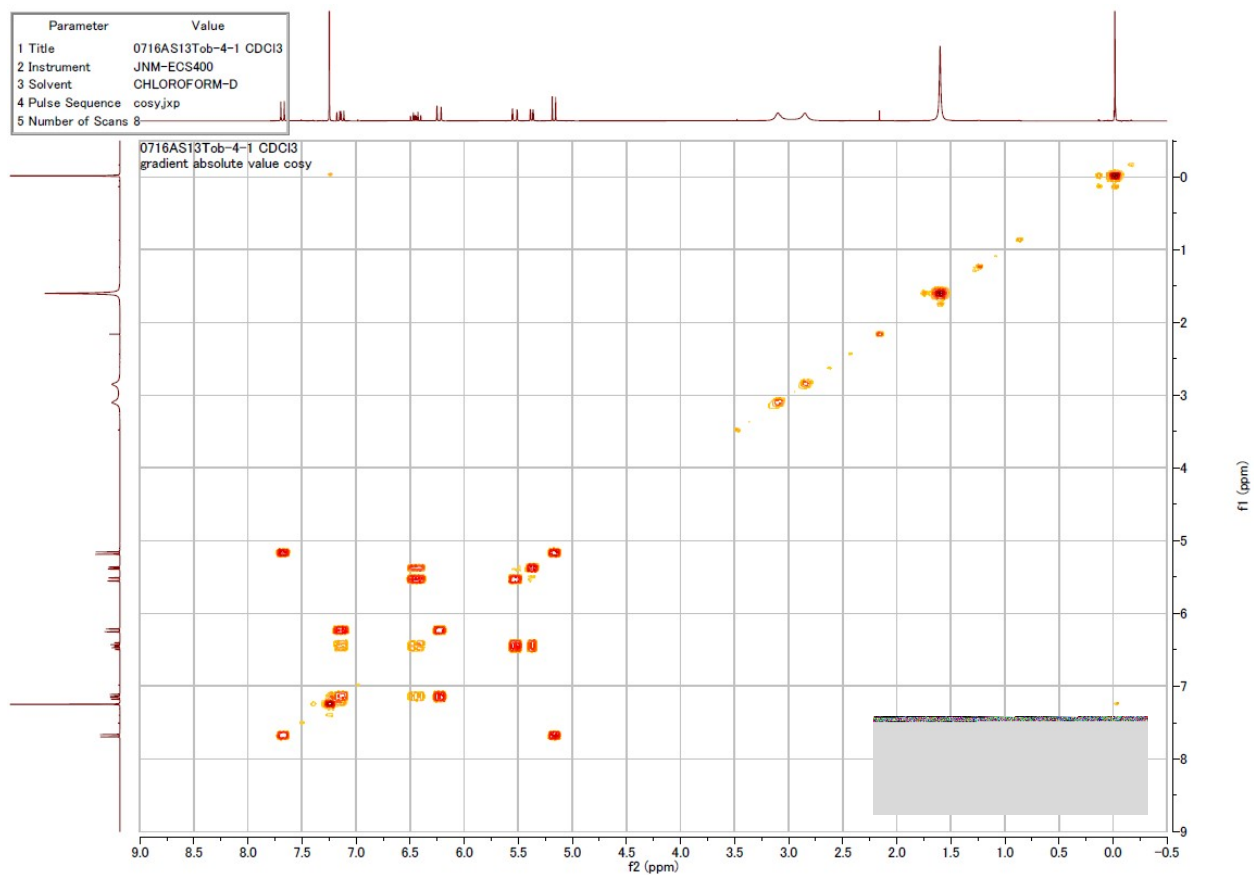


HMQC NMR (400 MHz) spectroscopic data of **19**. Measured in  $CDCl_3$ .



HMBC NMR (400 MHz) spectroscopic data of **19**. Measured in  $CDCl_3$ .

Parameter	Value
1 Title	0716AS13Tob-4-1 CDCl3
2 Instrument	JNM-ECS400
3 Solvent	CHLOROFORM-D
4 Pulse Sequence	cosyjxp
5 Number of Scans	8



COSY NMR (400 MHz) spectroscopic data of **19**. Measured in CDCl<sub>3</sub>.