

1 **Development of a cellulose-based 96-well plate vertical flow pull-down assay**

2 **Hoi Lok Cheng^{a,*}, Huan Jia^{a,*}, Sing Mei Lim^a, Say Yong Ng^a, Patthara Kongsuphol^a,**
3 **Megan E. McBee^a, Hadley D. Sikes^{a,b,#}**

4 ^a Antimicrobial Resistance Interdisciplinary Research Group (AMR-IRG), Singapore-MIT Alliance in Research
5 and Technology (SMART), 1 CREATE Way, 138602

6 ^b Department of Chemical Engineering, Massachusetts Institute of Technology (MIT), 25 Ames Street, Building
7 66, Cambridge, MA 02139, USA

8 * H.L.C and H.J contributed equally to this work.

9 # Hadley D. Sikes is the corresponding author, Email: sikes@mit.edu

10

11

12

1 **Supplementary Information**

2

A.

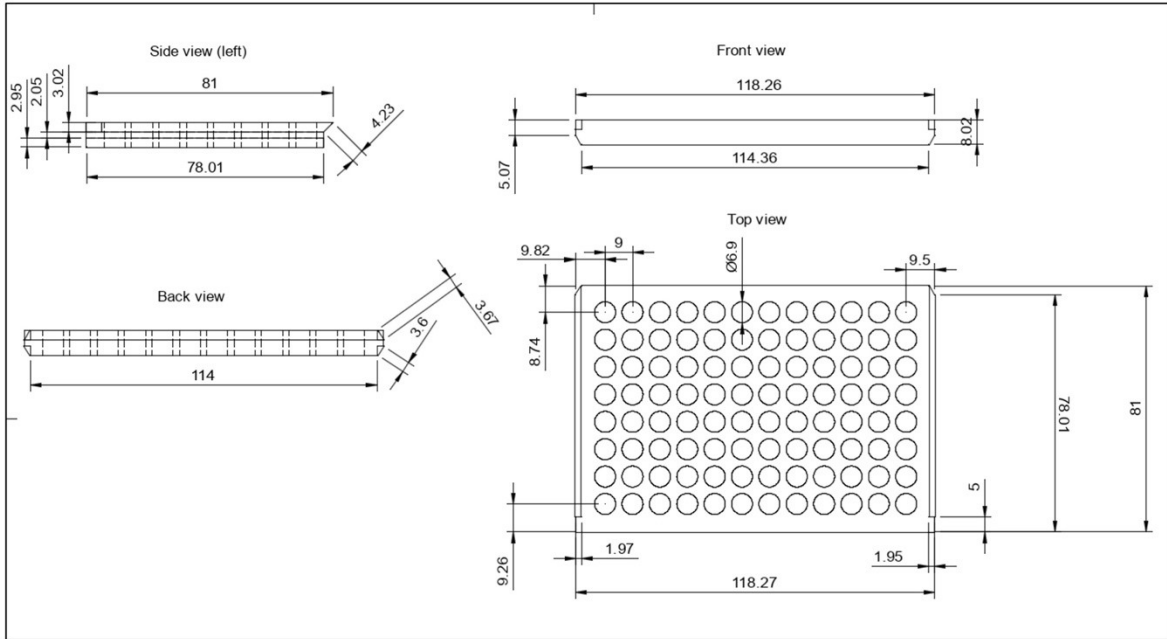

B.

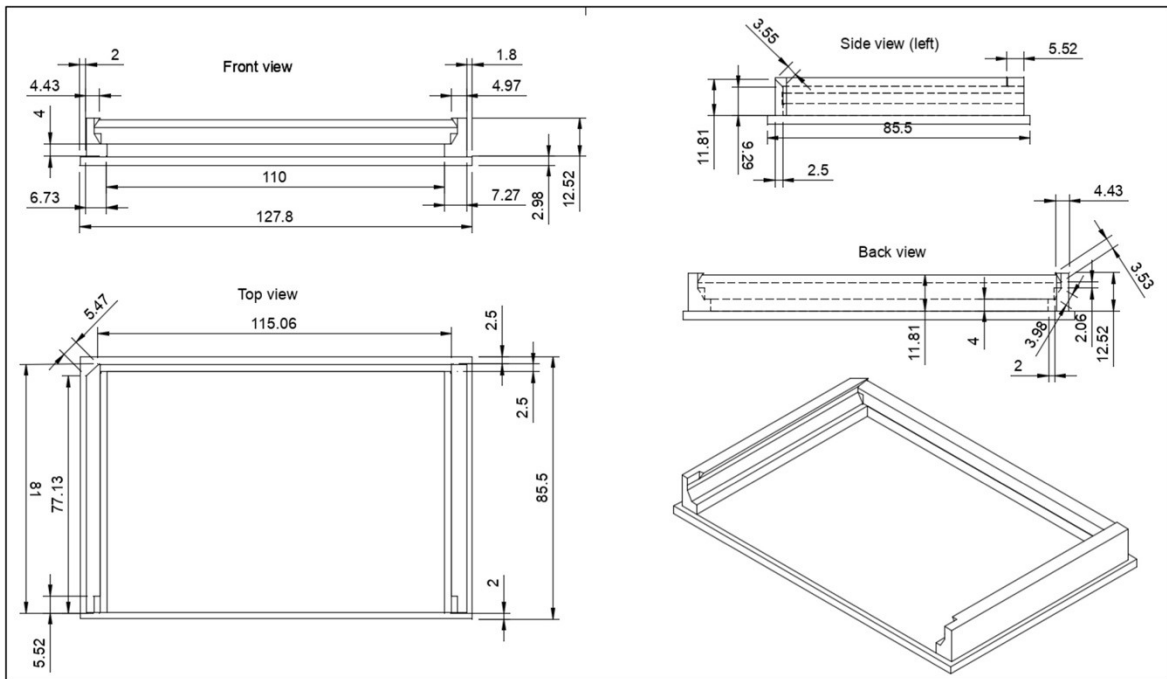

Figure S1. 2D drawings of dimensions for plate housing.

(A) Dimensions for the lid; and **(B)** Dimensions for the base.

3
4
5
6
7
8
9
10
11













Layouts	 5 mm  5 mm  5 mm	 5 mm  4 mm  4 mm	 5 mm  4 mm  3 mm	 5 mm  3 mm  3 mm	
	Test Results				
Type	a	b	c	d	

Figure S2. Optimization results for four types of flow pathway.

Table S1. Plate definition configurations and the readouts

Conf.	Well	Plate Size						Plate Height				Fluorescence Readouts	
		S/N	Diameter	Length	Width	Left well	Right well	Upper well	Lower well	Height	Tolerance	Cover	Skirt h
1	3500	127500	85000	14380	113380	11240	74240	17000	200	0	4500	441.7 ± 24.4	5.5%
2	3500	127500	85000	14380	113380	11740	74240	17000	200	0	4500	413.4 ± 35.9	8.7%
3	3500	127500	85000	14380	113380	12240	74240	17000	200	0	4500	387.5 ± 36.0	9.3%
4	3000	127500	85000	14380	113380	12240	74240	17000	200	0	4500	385.6 ± 35.6	9.2%
5	3000	127500	85000	15200	114000	11900	74500	17000	200	0	4500	278.0 ± 62.3	22.4%
6	3000	127500	85000	15200	114500	11900	74500	17000	200	0	4500	246.9 ± 48.0	19.5%
7	3000	127500	85000	15200	114300	11500	74500	17000	200	0	4500	281.6 ± 55.4	19.7%
8	3000	127500	85000	15200	114300	11900	74500	17000	200	0	4500	209.7 ± 13.7	6.5%

1

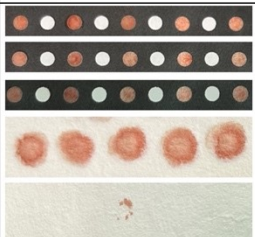
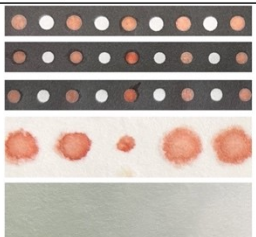
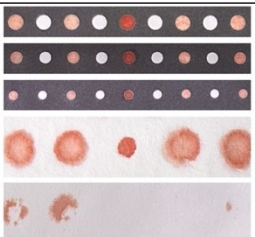
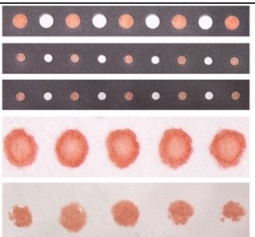
2 **Table S2. Raw fluorescence readouts for plates with high, mid and low signal samples**

Fluorescence Readouts												
High Signal Sample	2110	2709	2628	2501	2473	2277	2585	2333	2811	2615	2834	2671
	2024	2226	2544	2263	2703	2760	2413	2211	2421	2151	2343	2668
	2107	2479	2591	2520	2189	2603	2395	2228	2177	2314	2603	2636
	2646	2552	2583	2382	2237	2641	2586	2684	2654	2607	2434	2686
	2429	2560	2335	2645	2281	2892	2505	2263	2536	2473	2673	2415
	2367	2378	2720	2536	2481	2497	2286	2476	2333	2496	2487	2669
	2214	2472	2481	2532	2173	2359	2535	2494	2381	2546	2333	3027
	2721	2492	2599	2305	2152	1813	2246	2393	2075	2422	2170	2285
Mid Signal Sample	1130	1170	1120	993	1230	1076	1067	1052	1183	1187	1116	1133
	1246	1261	1147	1176	1200	1115	1016	885	1127	1130	1161	1234
	1413	1392	1148	1271	1183	1248	1166	1076	1065	1313	1259	1217
	1371	1075	1251	1151	1237	1148	1254	1233	1161	1474	1332	1225
	1329	1254	1217	1282	1238	1413	1218	1056	1089	1217	1301	1432
	1385	1371	1226	1285	1249	1169	1218	1143	1063	1408	1356	1424
	1357	1283	1267	1232	1244	1371	1372	1283	1337	1378	1408	1385
	1446	1265	1414	1309	1184	1295	1137	1190	1088	1153	1277	1319
Low Signal Sample	158	149	161	148	142	143	145	130	121	119	121	107
	143	141	145	141	141	135	133	130	131	122	133	123
	161	158	151	142	142	153	145	134	129	140	141	133
	130	121	123	120	128	114	124	114	116	112	114	99
	147	141	144	138	134	138	135	135	131	133	135	129
	142	141	148	142	135	140	134	126	142	133	122	126
	142	147	144	136	139	120	121	121	129	132	133	141
	140	138	143	137	130	102	131	125	138	133	139	141

3

4

5

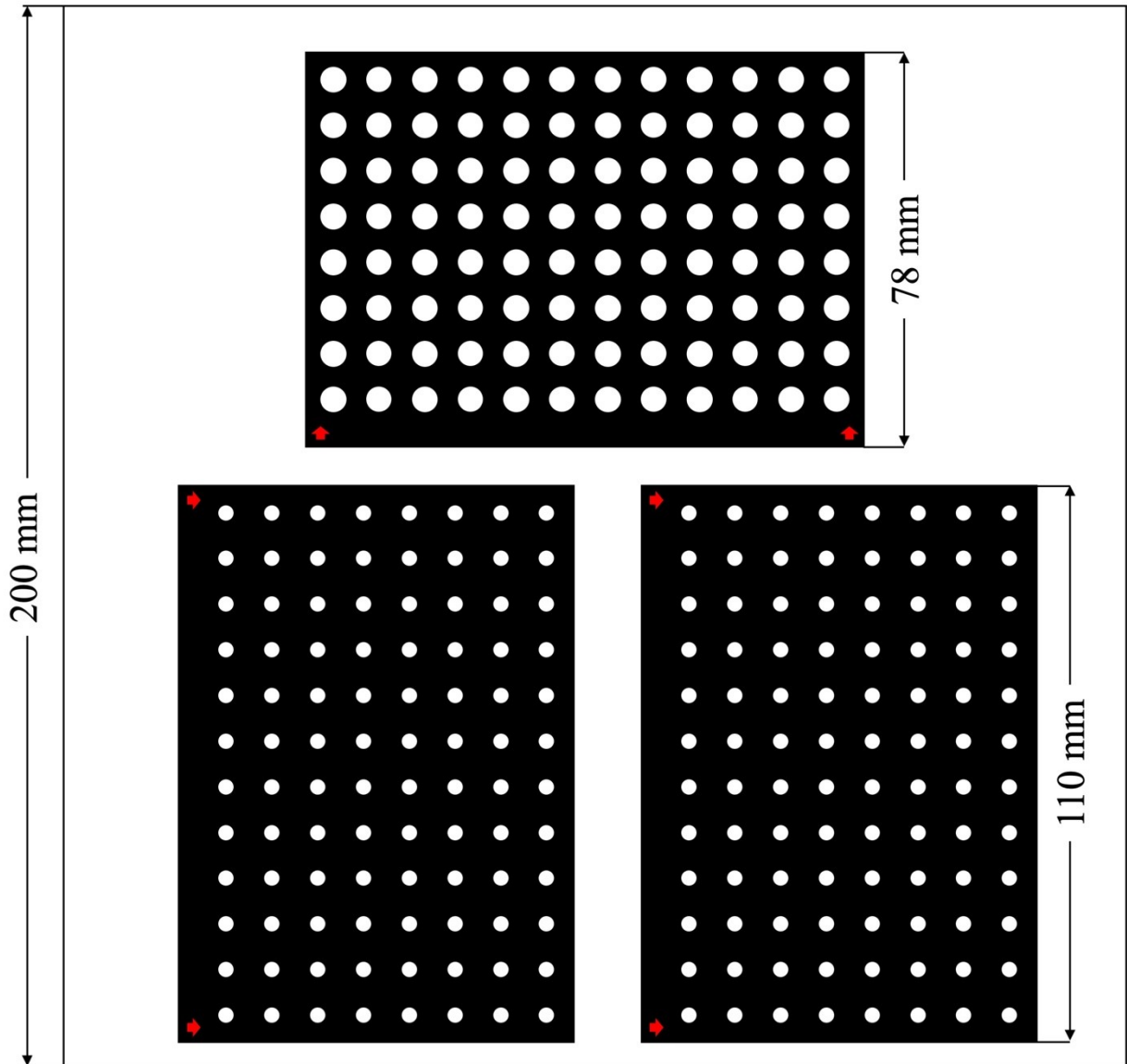

1
2 **Figure S3. Sample of wax print layout for three layers of cellulose test papers.**

3
4
5
6
7
8
9
10
11
12
13
14
15
16
17

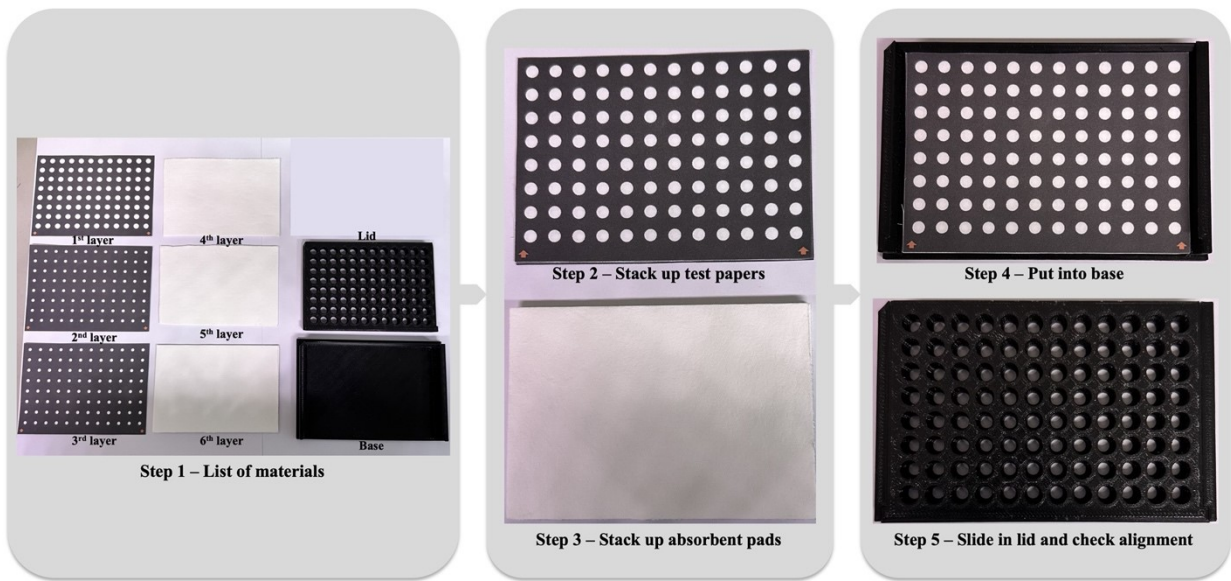

1
2
3
4
5

Figure S4. Demonstration of assembling a cellulose-based 96-well plate.

Sup. Video 1. Video illustration for assembling cellulose-based 96-well plate.