

### Supplementary Materials

#### **Intein based bioprocess for production of a synthetic antimicrobial peptide: An alternative route to solid phase peptide synthesis**

Anindya Basu,<sup>\*a</sup> Biswajit Mishra,<sup>a</sup> Sharmistha Dey,<sup>b</sup> and Susanna Su Jan Leong<sup>\*c,d</sup>

<sup>a</sup>School of Chemical and Biomedical Engineering, Nanyang Technological University, 62 Nanyang Drive, Singapore 637459

<sup>b</sup>Department of Biophysics, All India Institute of Medical Sciences, Ansari Nagar New Delhi 110029, India

<sup>c</sup>Singapore Institute of Technology, 10 Dover Drive, Singapore 138683

<sup>d</sup>Department of Biochemistry, Yong Loo Lin School of Medicine, National University of Singapore, 8 Medical Drive, Singapore 117597

\* Corresponding author:

Anindya Basu : e-mail address: [ceeab@nus.edu.sg](mailto:ceeab@nus.edu.sg); Tel: +65 65168482

and Susanna Su Jan Leong: email address: [Susanna.Leong@SingaporeTech.edu.sg](mailto:Susanna.Leong@SingaporeTech.edu.sg);

[bchslsj@nus.edu.sg](mailto:bchslsj@nus.edu.sg); Tel: +65 6592 8544;

Fax: +65 6592 1190

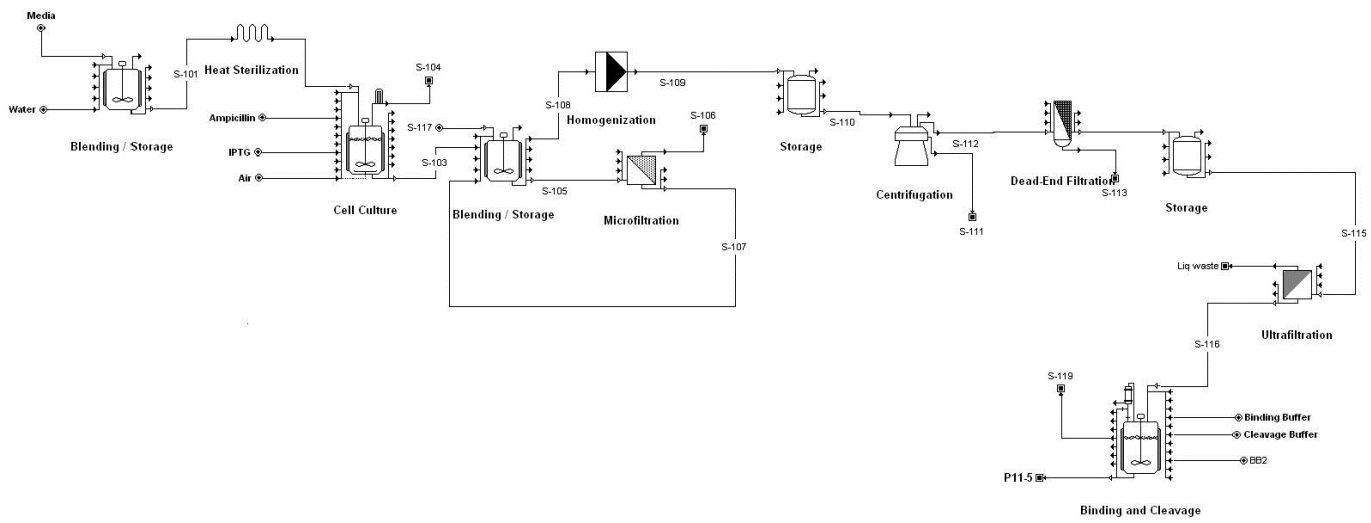

**Figure S1.** Schematic representation of the P11-5 production strategy using the intein bioprocessing platform.

**Table S1** Raw Material costs for the Intein Bioprocess

<b>Bulk Material</b>	<b>Price (\$)</b>
Ampicillin	8.84 / g
Disodium Edetate	220 / Kg
IPTG	78.72 / Kg
Di-potassium mono hydrogen phosphate	184 / Kg
Potassium dihydrogen phosphate	96 / Kg
Media	88 / Kg
Sodium Chloride	33.28 / Kg
Sodium Hydroxide	114.64 / Kg
Tris-chloride	268.8 / Kg
Tween 20	103.60 / Kg

**Table S2** Raw Material costs for the SPPS strategy

<b>Bulk Material</b>	<b>Unit Cost (\$)</b>
Acetic Acid	0.15 / mL
Anisole	139.38 / L
DCM	1.29 / L
Diethyl Ether	8.33 / L
DMF	141.67 / L
Ethyl Alcohol	71.67 / L
Fmoc-L Resin	72.75 / g
Fmoc-F	5.33 / g
Fmoc-G	3.10 / g
Fmoc-ILe	2.11 / g
Fmoc-K	10.48 / g
Fmoc-L	2.03 / g
HBTU	28.77 / g
NMM	619.17 / L
Piperidine	323.75 / L
TFA	1.27 / mL

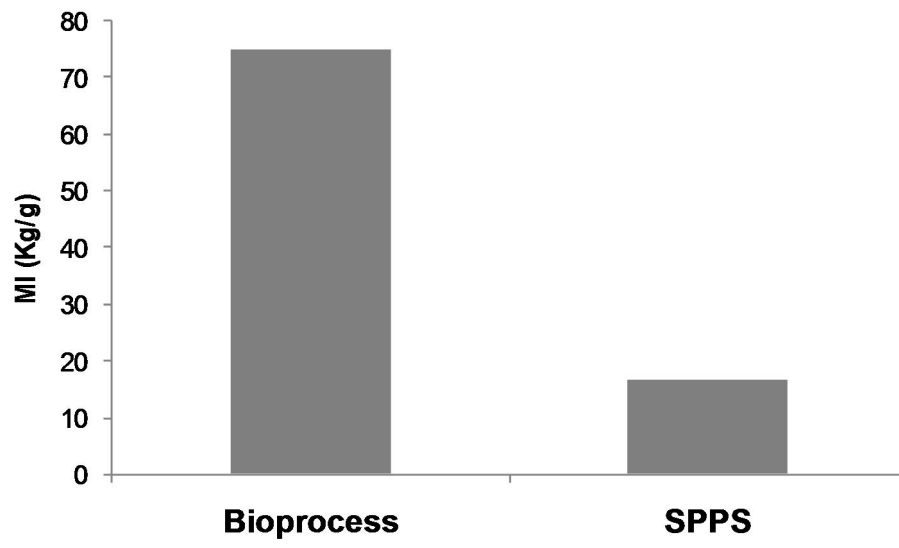

**Fig. S2** Input Mass Index (MI) for the SPPS and intein bioprocessing strategies.